

FURNACES FOR FOUNDRY

www.nabertherm.com

■ Made
■ in
■ Germany



Facts

- Production of Arts & Crafts, laboratory, dental and industrial furnaces since 1947
- Production site in Lilienthal/Bremen - Made in Germany
- 500 employees worldwide
- 150,000 customers in more than 100 countries
- Very wide product range of furnaces
- One of the biggest R&D departments in the furnace industry
- High vertical integration

Global Sales and Service Network

- Manufacturing only in Germany
- Decentralized sales and service close to the customer
- Own sales organization and long term sales partners in all important world markets
- Individual on-site customer service and consultation
- Fast remote maintenance options for complex furnaces
- Reference customers with similar furnaces or systems close to you
- Secured spare parts supply, many spare parts available from stock
- Further information see page 54

Setting Standards in Quality and Reliability

- Project planning and construction of tailor-made thermal process plants incl. material handling and charging systems
- Innovative controls and automation technology, adapted to customer needs
- Very reliable and durable furnace systems
- Customer test center for process assurance

Experience in Thermal Processing

- Thermal Process Technology
- Additive Manufacturing
- Advanced Materials
- Fiber Optics/Glass
- Foundry
- Laboratory
- Dental
- Arts & Crafts

Table of Contents



Processes

Which furnace for which process? 4
 Available heating concepts and exhaust gas systems 6

Furnaces for Special Applications

Bath furnaces B 30
 Laboratory tilting furnaces K/KC 31
 Melting furnaces in customized dimensions 32
 Cleaning furnaces for riser tubes SRO 35

Tilting Furnaces

Tilting furnaces K 10
 Tilting furnaces KB 12
 Tilting furnaces KBR with recuperative burner 14
 Product videos melting furnaces 15
 Tilting furnace KC 16

Accessories and Process Control and Documentation

Accessories for bale-out and tilting furnaces 38
 Control and documentation alternatives for melting furnaces 40
 Standard controllers, HiProSystems control and documentation 40
 Data storing and visualization 42
 Functions of the standard controller 43

Bale-Out Furnaces

Bale-out furnaces T 20
 Transportable bale-out furnaces TM 22
 Bale-out furnaces TB 24
 Bale-out furnaces TBR with recuperative burner 25
 Bale-out furnaces TC 26

Heat Treatment before and after Casting

Tempering plants for aluminum and steel 46
 Furnaces for continuous processes 48
 Wax burnout 50
 Additive manufacturing 52
 Energy efficiency concepts 53



Which Furnace for which Process?

Melt



Transportable bale-out furnace TM 150/10



Heat Treatment of Forms and Cast Pieces

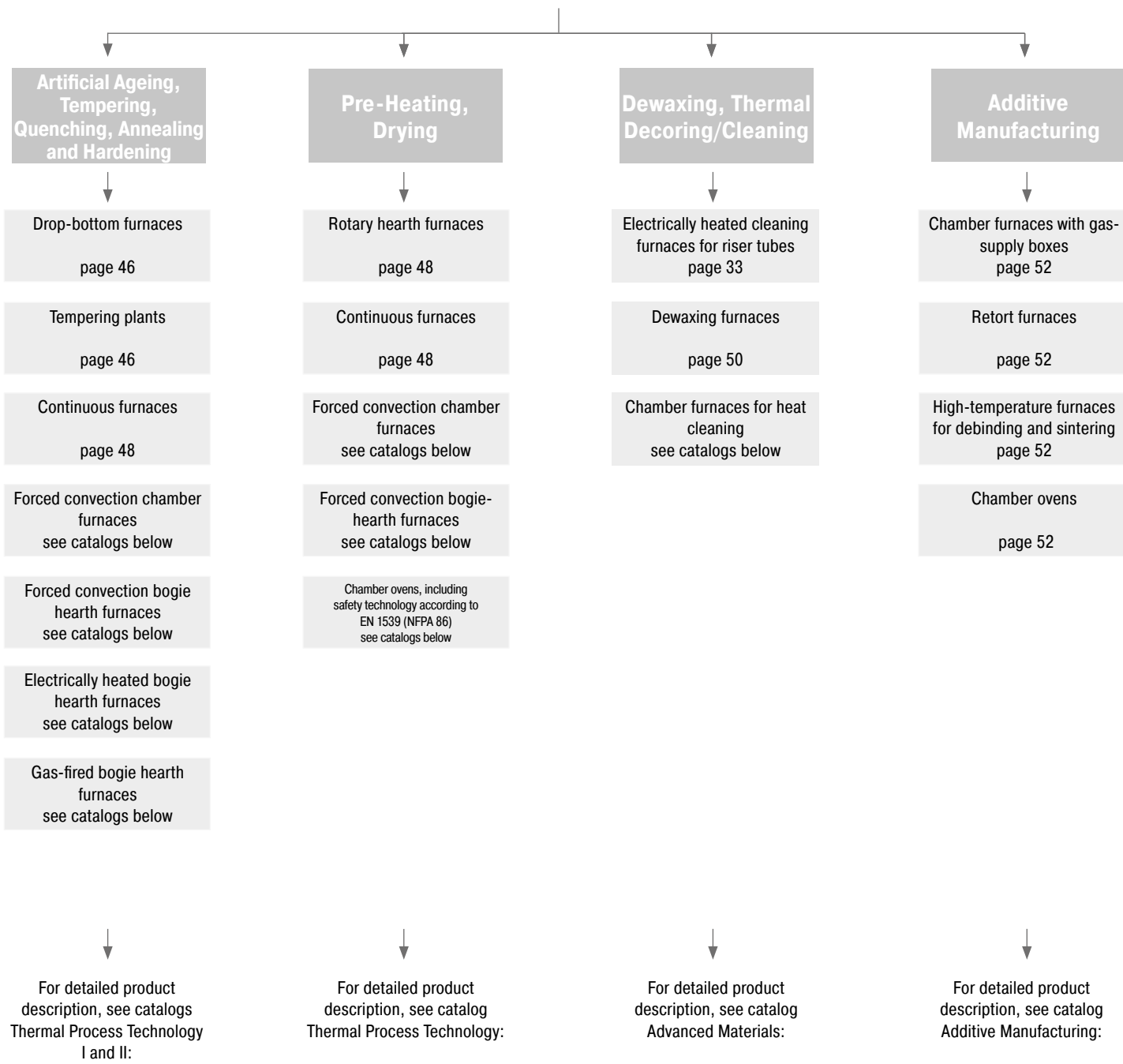

Available Heating Concepts and Exhaust Gas Systems for Melting Furnaces

Alternative Heating Technologies

The application of alternative heating technologies depends on the requirements for melt quality, productivity and energy efficiency. In principle either electrically or gas-fired melting furnaces can be used. In this context, with respect to costs the local pricing for the alternative energy play a decisive role.

Gas-Fired

Gas-fired melting furnaces are ideal for melting, particularly if equipped with exhaust gas discharge over the crucible edge. Side exhaust gas discharge is best if a high melt quality is required. However, a higher melt quality means a lower energy efficiency since a fuel-fired furnace with side exhaust gas discharge consumes approx. 20-25 % more energy than a melting furnace with an exhaust gas discharge over the crucible edge.

Fuel-fired furnaces provide for optimal energy efficiency in combination with highest melt quality due to their burner system that includes heat recovery via recuperator. The hot exhaust gases from the melting furnace preheat the combustion air for the burner via a heat exchanger. This system leads to savings of up to 25 % compared to conventional fuel-fired furnaces with a side exhaust gas discharge.

Electric Heating

If the melt quality and energy efficiency take priority, an electrically heated furnace is the best choice. The heating is controlled very steadily and precisely. The melt is not polluted through immissions from a fuel-fired heating. Electrically heated furnaces can achieve up to 85 % of the melting performance of fuel-fired furnaces with a side exhaust gas discharge. If the furnaces are used only for holding, we recommend the T.../10 models, which are very energy efficient due to their very good insulation and reduced connected load. For demanding copper alloys up to a melting temperature of 1320 °C, the TC/KC models with heating via SiC rods are recommended.

Alternative Exhaust Gas Systems

Exhaust Gas Discharge over the Crucible Edge

Exhaust gas discharge over the crucible edge is the standard design for our gas and oil-fired crucible furnaces, except for the TB models for furnace temperatures of 1200 °C, since these furnaces are normally used as holding furnaces. Due to the high melting performance, the furnaces are perfectly suited for melting. This type of exhaust gas discharge is characterised as follows:

- + Very high melting performance, ideal for use as a melting furnace
- + Low power consumption since the crucible is not just heated from the outside but part of the heat also enters the crucible from above. Energy savings of up to 20 % compared to furnaces with a side exhaust gas discharge
- Limitations on the melt quality due to higher burn-off and increased hydrogen absorption by the melt from the exhaust gases
- Bath control not recommended

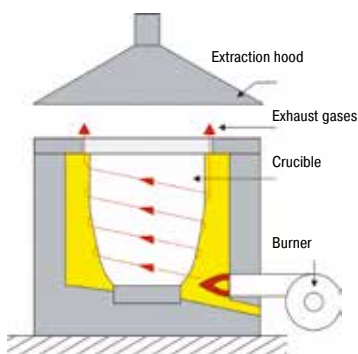

Exhaust gas discharge over the crucible edge

Side Exhaust Gas Discharge

a) without Recuperator Technology

The side exhaust gas discharge is available for all fuel-fired crucible furnaces. Although the melting performance is not as high as with an exhaust gas discharge over the crucible edge, it provides for better melt quality and, in combination with a bath control, is highly recommended for holding operation.

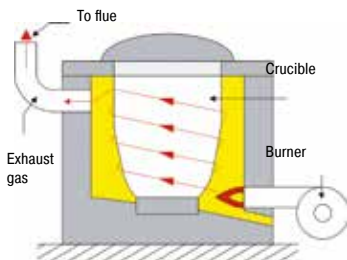

Side exhaust gas discharge

- + High melt quality due to low burn-off and reduced hydrogen inclusions in the melt
- + Swing lid-reduction of power consumption up to 50 % during holding with a closed swing lid
- + Operator exposed to less heat in the area above the crucible
- + Best melt quality if a bath control for precise temperature control is used

- Lower melting performance compared to furnaces with exhaust gas discharge over the crucible edge
- Power consumption during melting around 25 % higher compared to furnaces with exhaust gas discharge over the crucible edge

b) with Recuperator Technology

Fuel-fired furnaces with burner systems that include heat recovery via a recuperator provide for optimum energy efficiency in connection with a top melt quality. The combustion air for the burner is pre-heated with the hot exhaust gases from the furnace via heat exchanger. The system results in savings of up to 25 % compared to conventional fuel-fired furnaces with side exhaust gas discharge.

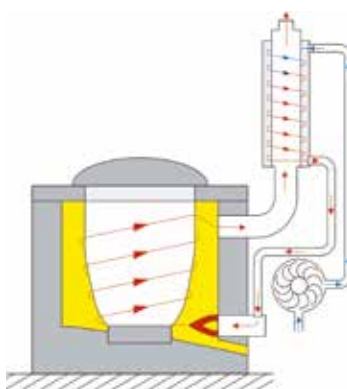

Side exhaust gas discharge with recuperator technology

Depending on the utilisation the relatively higher acquisition costs pay off already after a short period of time.

- + Burner systems with a recuperator system save around 25 % of the power compared to furnaces with a side exhaust gas discharge
- + High melt quality due to low burn-off and reduced hydrogen absorption in the melt
- + Reduced power consumption by up to 50 % during holding with a closed swing lid
- + Operator exposed to less heat in the area above the crucible
- + Best melt quality if a bath control for a precise temperature control is used

- Lower melting performance than furnaces with exhaust gas discharge over the crucible edge
- Power consumption during melting around 20-25 % higher than furnaces with exhaust gas discharge over the crucible edge

Decision Aid for Melting Furnaces

	Use	Melting Material	Max. Melt Temperature	Productivity	Melt Quality	Energy Consumption	Noise Emissions
Models TB/KB (not for Models TB ../12) Exhaust gas discharge over the crucible edge	Melting	Al + Cu	++	++	-	0	-
Models TB/KB Side exhaust gas discharge	Melting + Holding	Al + Zn	0	+	+	-	-
Models TBR/KBR Side exhaust gas discharge with recuperator	Melting + Holding	Al	0	+	+	+	-
Models T/K Electrically heated with bath control	Melting + Holding	Al + Zn	0	0	+++	++	+
Models T/K Electrically heated without bath control	Melting + Holding	Al + Zn + Cu	+	0	++	++	+
Modelle T/TM../10 Electrically heated with bath control	Holding	Al	-	-	+++	+++	+
Models TC/KC Electrically heated via SiC rods	Melting + Holding	Cu	+++	+	++	+	+

Tilting Furnaces

Tilting furnaces are characterized by very good melt quality and high melting performance with optimum energy efficiency. Depending on the model, for aluminum, zinc or copper alloys.



Incl. crucible



Electro-hydraulic tilting device with safe two-hand operation on the furnace



Exclusive use of insulation materials without categorization according to EC Regulation No 1272/2008 (CLP)



Uniform and precise pouring due to optimum pivot point



Defined application within the constraints of the operating instructions



As additional equipment: Process control and documentation via Nabertherm Control Center (NCC) for monitoring, documentation and control



Furnace Group	Model	Page
Tilting furnaces K	K	10
Tilting furnaces KB	KB	12
Tilting furnaces KBR with recuperative burner	KBR	14
Product videos melting furnaces		15
Tilting furnaces KC	KC	16

Tilting Furnaces K

Electrically Heated, for Melting and Holding

The electrically heated tilting furnaces are characterized by very good melt quality and high melting performance with optimum energy efficiency. They are ideal as a flexible solution for pre-melting but also for direct pouring into large moulds.



Tilting furnace K 150/12

Standard Equipment

- K ../12 for aluminum and zinc alloys
- K ../13 for copper alloys such as bronze or brass
- Free-radiating heating elements on support tubes for long service life and simple replacement
- Twelve months warranty on heating elements
- Multi-layer insulation for optimum energy efficiency and low external wall temperatures
- Incl. crucible
- Electro-hydraulic tilting device with safe two-hand operation on the furnace
- Uniform and precise pouring due to optimum pivot point
- Emergency outlet for safe draining of the melt in case of crucible breakage
- No exhaust gas discharge needed
- Integrated safety system which continues to operate the furnace at reduced power in case of malfunction in the thermocouple, in order to prevent the freezing of the melt
- Over-temperature limiter in furnace chamber for protection against overheating. The limiter switches the heating off when the set limit temperature is reached, and only switches it back on after the temperature has fallen again.
- Low-maintenance furnace chamber control with temperature measurement behind the crucible



Tilting furnace K 150/12 and bale-out furnace T 180/11 as premelting and holding system

Additional Equipment

- Safety fence
- Work platform for easy charging
- Collecting pan under the emergency outlet see page 39
- Crucible breakage monitor with visual and audible signal (only for models K ../12)
- Bath control with thermocouples in the furnace chamber and in the melt. The furnace temperature is controlled through the melt. Temperature overshoots are reduced, thus the quality of the melt is improved
- Heating system operated through thyristors
- Multi-step switching of the furnace heat (see page 43)
- Models with increased heating power
- Process control and documentation via Nabertherm Control Center (NCC) for monitoring, documentation and control see page 42



Three tilting furnaces with work platform for melting of aluminum

Model	Tmax furnace °C	Tmax melt bath °C	Crucible	Capacity in kg			Heating power in kW ⁴	Melting performance ^{3,6} in kg/h	Consumption melting ⁶ kWh/kg	Consumption holding Lid closed/open kWh/h	Outer dimensions ⁵ in mm			Weight in kg
				Al	Zn	Cu					W	D	H	
K 80/12	1200	1050	TP 287	180	470	-	50	126 ¹	0.4 ¹	4/10 ¹	2050	1520	1580	1750
K 150/12	1200	1050	TP 412	330	870	-	60	147 ¹	0.4 ¹	5/12 ¹	2120	1600	1860	2350
K 180/12	1200	1050	TP 412H	370	980	-	60	160 ¹	0.4 ¹	5/12 ¹	2120	1600	1860	2450
K 240/12	1200	1050	TP 587	570	1500	-	80	180 ¹	0.4 ¹	8/17 ¹	2260	1760	1860	2800
K 360/12	1200	1050	TBN 800	750	-	-	100	260 ¹	0.4 ¹	11/20 ¹	2370	1810	1950	3500
K 400/12	1200	1050	TBN 1100	1050	-	-	126	295 ¹	0.4 ¹	12/22 ¹	2370	1930	2100	3700
								Cu	Cu					
K 10/13	1300	1150	A 70	20	50	70	16	47 ²	0.3 ²	5/8 ²	1890	1240	1440	1000
K 20/13	1300	1150	A 150	45	120	150	20	63 ²	0.3 ²	5/8 ²	1890	1400	1460	1300
K 40/13	1300	1150	A 300	90	240	300	26	84 ²	0.3 ²	5/8 ²	2000	1450	1540	1650
K 80/13	1300	1150	TP 287	180	470	550	50	190 ²	0.3 ²	6/11 ²	2050	1520	1580	1950

¹Al at 700 °C

²CuZn at 1000 °C

³The specified melting performances are maximum values. In practice, approx. 80 % are achieved.

⁴Depending on furnace design connected load might be higher

⁵External dimensions vary when furnace is equipped with additional equipment. Dimensions on request.

⁶ Values for other materials, e. g. zinc, on request



Charging of transport ladle with tilting furnace K 360/12



Tilting furnace K 40/13 with extended spout
(sculpture foundry Knaak)



Filling a mould with liquid bronze
(photographer Andrea Künstle)

Tilting Furnaces KB

Gas-Fired, for Melting and Holding

The gas-fired or oil-heated tilting furnaces in the KB product lines provide for high melting performance, making them ideal for melting operations. The use of high-quality insulation materials results in very low energy consumption. Designed with an exhaust vent over the crucible edge, these tilting furnaces achieve very high melting rates and optimum energy efficiency.



Tilting furnace KB 400/12 with exhaust gas discharge over the crucible edge

Standard Equipment for all Tilting Furnaces

- KB ../12 for aluminum and zinc alloys
- KB ../14 for copper alloys such as bronze or brass
- Modern and powerful two-stage burner for high melting capacity and low maintenance operation
- Fuel heating with either gas or oil
- Exhaust gas discharge over the crucible edge see page 6
- Multi-layer insulation for optimum energy efficiency and low external wall temperatures
- Incl. crucible
- Electro-hydraulic tilting device with safe two-hand operation on the furnace
- Uniform and precise pouring due to optimum pivot point
- Emergency outlet for safe discharge of the melt in case of a crucible break
- Integrated safety system which continues to operate the furnace at reduced power in case of malfunction in the thermocouple, in order to prevent the freezing of the melt
- Over-temperature limiter for the furnace chamber with automatic reset to protect against over-temperature. The limit controller switches off the heating when the pre-set limit temperature has been reached and does not switch it on again until the temperature falls below the setting again.
- Low-maintenance furnace chamber control with temperature measurement behind the crucible

Standard Equipment for Tilting Furnaces KB ../14

- Insulation with an additional wear-and-tear layer made of copper-resistant refractory concrete

Additional Equipment for all Tilting Furnaces

- Safety fence
- Work platform or platform for easier charging
- Collecting pan under the emergency outlet see page 39
- Information on other accessories see page 38 - 39

Additional Equipment for Tilting Furnaces KB ../12

- Side exhaust gas discharge including cover see pages 7
- Insulated exhaust gas diverter connecting piece (exhaust flue) for side-wall exhaust gas vent to a connected customer suction system
- Crucible breakage monitoring with optical and acoustic signal
- SMS-alarm message in case of crucible breakage
- Bath control system (only when equipped with side exhaust gas discharge) see page 40
- Process control and documentation via Nabertherm Control Center (NCC) for monitoring, documentation and control see page 42



Melting furnace plant consisting of two tilting furnaces KB 360/12 with side exhaust gas discharge and one work platform



Tilting furnace KB 150/12 in production

Model	Tmax furnace °C	Tmax melt bath °C	Crucible	Capacity in kg			Burner output kW	Melting performance ^{3,6} in kg/h Al	Consumption melting ⁶ kWh/kg Al	Consumption holding Lid closed kWh/h	Outer dimensions ⁴ in mm			Weight in kg
				Al	Zn	Cu					W ⁵	D	H	
KB 80/12	1200	1050	TP 287	180	470	-	300	220 ¹	1.3 - 1.5 ¹	10	2730	1530	1680	2100
KB 150/12	1200	1050	TP 412	330	870	-	300	240 ¹	1.0 - 1.3 ¹	11	2830	1630	1880	2600
KB 180/12	1200	1050	TP 412 H	370	970	-	300	260 ¹	1.0 - 1.3 ¹	13	2830	1630	1980	2800
KB 240/12	1200	1050	TP 587	570	1500	-	390	400 ¹	1.0 - 1.3 ¹	15	3120	1840	1980	3100
KB 360/12	1200	1050	TBN 800	750	-	-	450	420 ¹	1.0 - 1.3 ¹	17	3170	1890	2080	3300
KB 400/12	1200	1050	TBN 1100	1000	-	-	450	450 ¹	1.0 - 1.3 ¹	19	3170	1890	2150	3600
KB 40/14	1400	1250	R 400/TP 982	-	-	400	400	330 ²	1.0 - 1.3 ²	22	2710	1530	1550	2400
KB 60/14	1400	1250	R 500	-	-	500	400	360 ²	1.0 - 1.3 ²	25	2710	1530	1550	2700
KB 80/14	1400	1250	R 600	-	-	600	400	380 ²	1.0 - 1.3 ²	25	2710	1530	1710	3400

¹Al at 700 °C

²CuZn at 1000 °C

³The stated melting performances are maximum values. Daily operation comes up to roughly 80 %.

⁴External dimensions vary when furnace is equipped with additional equipment. Dimensions on request.

⁵Incl. burner and hydraulic system

⁶ Values for other materials, e.g. zinc, on request



Hydraulic system with flame resistant hydraulic fluid



Two-stage burner, mounted on furnace frame



Cast copper alloy

Tilting Furnaces KBR with Recuperative Burner Gas-Fired, for Melting and Holding of Aluminum

The fuel-heated tilting furnaces with recuperative burner provide for optimum energy utilization combined with very high melt quality. Fitted with a burner system including heat-recovery system the energy efficiency of fuel-heated tilting furnaces with the side exhaust gas discharge is significantly improved.

Depending on utilization the exhaust gases from the crucible furnace are guided through a heat exchanger in order to preheat the combustion air for the burner. The system provides for energy savings of up to 25 % compared to conventional fuel-heated tilting furnaces with side exhaust gas discharge. The higher purchase costs are amortized within a short time.

The KBR series is recommended when both high melt quality requirements and high energy efficiency are required, and the speed of the melting process is of secondary interest. If the fastest possible melting rate is important for the process and a particularly high quality of the melt is of secondary importance, a conventional tilting furnace KB with exhaust ducting over the edge of the crucible (see page 6) is recommended.



Tilting furnace KBR 240/11

Standard Equipment as KB Models, but

- Heat exchanger in the exhaust gas duct to preheat the combustion air for the burners
- Energy savings of up to 25 % in comparison to other fuel-heated melting furnaces featuring side-wall exhaust gas vents
- Side exhaust gas discharge
 - Low burn-off provides for high quality melt
 - Low hydrogen absorption by the melt
 - Low heat exposure for the operator in the area above the crucible
- Max. furnace temperature of 1100 °C for melt bath temperatures up to 950 °C
- Required minimum gas pressure at full load: 80 mbar

Model	Tmax furnace °C	Tmax melt bath °C	Crucible	Capacity in kg	Burner output kW	Melting performance ² in kg/h	Consumption melting in kWh/kg	Consumption holding Lid closed kWh/h	Outer dimensions ³ in mm			Weight in kg
				Al		Al	Al	W ⁴	D	H		
KBR 240/11	1100	950	TP 587	570	390	320 ¹	1.1 - 1.4 ¹	13	2580	2300	1980	3600
KBR 360/11	1100	950	TBN 800	750	450	340 ¹	1.1 - 1.4 ¹	15	2580	2350	2080	3800
KBR 400/11	1100	950	TBN 1100	1000	450	360 ¹	1.1 - 1.4 ¹	16	2580	2350	2150	4100

¹Al at 700 °C

²The stated melting performances are maximum values. Daily operation comes up to roughly 80 %.

³External dimensions vary when furnace is equipped with additional equipment. Dimensions on request.

⁴Incl. burner



Tilting furnace KBR 240/11 during filling of a transport ladle



Melting thermocouple



Insulated connecting piece for side-wall exhaust gas vent to a connected customer suction system

Product Videos Melting Furnaces



Charging of transport ladle with tilting furnace K 360/12

Tilting Furnace for Aluminum

Typical solution for flexible premelting. Several electric tilting furnaces, for melting of partly different alloys, and subsequent transfer of the melt to the casting location by means of a crane transport ladle. For further information on this furnace series, also see page 10.

Scan for product video „Tilting furnace for aluminum“



Tilting Furnace and Transportable Holding Furnace

Fast melting in the gas-fired tilting furnace and subsequent filling of transportable holding furnaces. By filling the holding furnace directly at the premelter, the number of refilling operations can be kept low. This has a positive effect on both energy efficiency and melt quality. For more information on these furnaces, also see page 12 and page 25.

Scan for product video „Tilting furnace KB 360/12 and transportable holding furnace TM 150/11“



Tilting furnace KB 360/12 and transportable holding furnace TM 150/11



Tilting furnace KC 80/14

SiC Rod Heated Tilting Furnace/Cupola Melting Furnace

The SiC rod-heated furnace of the KC/TC series shown here is characterized by its high maximum temperature and thus also enables the melting of alloys with particularly high casting temperatures, such as aluminum bronze or certain precious metals.

Scan for product video „Tilting furnace for precious metals“



Tilting Furnace KC

SiC-Rod-Heated, for Melting

The electrically heated tilting furnaces of the KC product lines are characterized by a higher maximal temperature than achievable with wire heated melting furnaces. This allows for processing of demanding copper alloys such as aluminum bronze. These furnaces are designed for permanent operation at working temperatures.



Tilting furnace KC 150/14

Standard Equipment

- Melt temperatures up to 1320 °C
- Symmetrical heating via powerful SiC rods
- SiC-Crucible
- Simple exchange of individual heating elements
- Heat operation by thyistors in phase-angle mode with performance control: The resistance of the SiC rods changes with temperature and age. Performance control ensures constant power of heating irrespective to the condition of the heating elements.
- Multi-layer insulation for optimum energy efficiency and low external wall temperatures
- Electro-hydraulic tilting device with safe two-hand operation on the furnace
- Uniform and precise pouring due to optimum pivot point
- Emergency outlet for safe draining of the melt in case of crucible breakage
- Exclusive use of insulation materials without categorization according to EC Regulation No 1272/2008 (CLP)
- Over-temperature limiter in furnace chamber for protection against overheating. The limiter switches the heating off when the set limit temperature is reached, and only switches it back on after the temperature has fallen again.
- Low-maintenance furnace chamber control with temperature measurement behind the crucible



Tilting furnace KC 180/14

Additional Equipment

- Additional heating transformers provide for significant reduction of the connected load
- Safety fence
- Work platform for simplified loading
- Process control and documentation via Nabertherm Control Center (NCC) for monitoring, documentation and control see page 42
- For information on other accessories see page 38 - 39



Tilting furnace KC 80/14 during casting

Model	Tmax furnace °C	Tmax melt bath °C	Crucible	Capacity in kg	Heating power in kW ¹	Connected load in kW	Melting performance ³ in kg/h Cu	Outer dimensions ⁴ in mm			Weight in kg
				Cu				W	D	H	
KC 20/14	1450	1320	A 150	150	36	69	120 ²	1710	1900	1050	1500
KC 40/14	1450	1320	A 300	300	36	69	120 ²	1770	1900	1100	1600
KC 80/14	1450	1320	TPC 287	550	48	94	180 ²	1880	1970	1160	1900
KC 150/14	1450	1320	TPC 412	1000	66	112	220 ²	2000	2070	1300	2700
KC 180/14	1450	1320	TPC 412H	1150	99	187	230 ²	2000	2070	1500	3000

¹Reduction of connected load by optional heating transformers

²CuZn at 1000 °C

³The specified melting performances are maximum values. In practice, approx. 80 % are achieved.

⁴External dimensions vary when furnace is equipped with additional equipment. Dimensions on request.



Switchgear with thyristors in phase angle operation for economic power consumption



Heated on both sides by high performance SiC rods



Swing lid with good sealing to collar plate to avoid heat loss over the crucible opening

Bale-Out Furnaces

Bale-out furnaces are suitable for melting and holding and are characterized by good energy efficiency. Depending on the model, for aluminum, zinc or copper alloys.



Low-maintenance furnace chamber control with temperature measurement behind the crucible



Multi-layer insulation for optimum energy efficiency and low external wall temperatures



Exclusive use of insulation materials without categorization according to EC Regulation No 1272/2008 (CLP)



Over-temperature limiter in furnace chamber for protection against overheating. The limiter switches the heating off when the set limit temperature is reached, and only switches it back on after the temperature has fallen again.



Defined application within the constraints of the operating instructions



As additional equipment: Process control and documentation via Nabertherm Control Center (NCC) for monitoring, documentation and control



Furnace Group	Model	Page
Bale-out furnaces T	T	20
Bale-out furnaces TB	TB	22
Bale-out furnaces TBR with recuperative burner	TBR	24
Transportable bale-out furnaces TM	TM	25
Bale-out furnaces TC	TC	26

Bale-Out Furnaces T

Electrically Heated, for Melting and Holding

Whether in manual pouring operation or integrated in an automated casting cell, the electrically heated tilting furnaces are characterized by very good melt quality, optimum energy efficiency and low-maintenance operation. These furnaces are available with reduced connected load for only holding of aluminum alloys or with increased power for holding and melting as allrounders.



Bale-out furnace T 110/11

Standard Equipment

- T/10 for holding aluminum alloys
- T/11 for melting and holding aluminum and zinc alloys
- T/13 for melting and holding copper alloys such as bronze or brass
- Free radiating heating elements arranged on four sides on support tubes provide for long service life and easy replacement
- Twelve months warranty on heating elements
- High melting performance with temperature uniformity in the melt
- Multi-layer insulation for optimum energy efficiency and low external wall temperatures
- Emergency outlet for safe draining of the melt in case of crucible breakage
- No exhaust gas discharge needed
- Integrated safety system which continues to operate the furnace at reduced power in case of malfunction in the thermocouple, in order to prevent the freezing of the melt
- Over-temperature limiter in furnace chamber for protection against overheating. The limiter switches the heating off when the set limit temperature is reached, and only switches it back on after the temperature has fallen again.
- Low-maintenance furnace chamber control with temperature measurement behind the crucible



Bale-out furnace T 800/11

Additional Equipment

- Crucible of clay-graphite or SiC
- Collecting pan under the emergency outlet see page 39
- Crucible breakage monitor with visual and audible signal (not for T/13)
- Bath control with thermocouples in the furnace chamber and in the melt (not for T/13). The furnace temperature is controlled through the melt. Temperature overshoots are reduced, thus the quality of the melt is improved
- Heating system operated through thyristors
- Multi-step switching of the furnace heat (see page 43)
- Higher electrical ratings to increase melting performance
- Work platform for ease of charging
- Alarm message via SMS, e. g. in the event of crucible breakage
- Process control and documentation via Nabertherm Control Center (NCC) for monitoring, documentation and control see page 42
- For information on other accessories see page 38 - 39



Bale-out furnace T 80/13 for gunmetal in a sand foundry shop

Model	Tmax furnace °C	Tmax melt bath °C	Crucible	Capacity in kg			Heating power in kW ⁴	Melting performance ^{3,6} in kg/h	Consumption melting ⁶ kWh/kg	Consumption holding Lid closed/open kWh/h	Outer dimensions ⁵ in mm			Weight in kg
				Al	Zn	Cu					W	D	H	
T 80/10	1000	800	BU 200	200	-	-	20	-	-	4/9 ¹	1110	1110	940	1050
T 110/10	1000	800	BU 300	300	-	-	26	-	-	5/10 ¹	1200	1200	1040	1240
T 150/10	1000	800	BU 350	350	-	-	38	-	-	5/10 ¹	1200	1200	1140	1330
T 180/10	1000	800	BU 500	500	-	-	42	-	-	7/15 ¹	1370	1370	1250	1400
T 240/10	1000	800	BU 600	600	-	-	50	-	-	7/15 ¹	1370	1370	1350	1530
T 360/10	1000	800	BN 800	800	-	-	50	-	-	8/17 ¹	1510	1510	1490	2000
T 450/10	1000	800	BU 1800 H 830	1040	-	-	50	-	-	13/20 ¹	1685	1685	1360	2400
T 560/10	1000	800	BU 1800 H 1000	1400	-	-	50	-	-	13/23 ¹	1685	1685	1530	2550
T 800/10	1000	800	BU 1800	1800	-	-	70	-	-	15/25 ¹	1685	1685	1830	2800
								Al	Al					
T 10/11	1100	950	A 70	20	50	-	16	32 ¹	0.4 ¹	3/5 ¹	860	860	790	550
T 20/11	1100	950	A 150	45	110	-	20	42 ¹	0.4 ¹	3/6 ¹	940	940	790	650
T 40/11	1100	950	A 300	90	230	-	26	58 ¹	0.4 ¹	3/7 ¹	1010	1010	880	750
T 80/11	1100	950	BU 200	200	520	-	50	126 ¹	0.4 ¹	4/9 ¹	1110	1110	940	1050
T 110/11	1100	950	BU 300	300	790	-	60	136 ¹	0.4 ¹	5/10 ¹	1200	1200	1040	1240
T 150/11	1100	950	BU 350	350	920	-	60	147 ¹	0.4 ¹	5/10 ¹	1200	1200	1140	1330
T 180/11	1100	950	BU 500	500	1320	-	70	168 ¹	0.4 ¹	7/15 ¹	1370	1370	1250	1400
T 240/11	1100	950	BU 600	600	1580	-	80	180 ¹	0.4 ¹	7/15 ¹	1370	1370	1350	1530
T 360/11	1100	950	BN 800	800	2110	-	110	200 ¹	0.4 ¹	8/17 ¹	1510	1510	1490	2000
T 450/11	1100	950	BU 1800 H 830	1040	2740	-	110	200 ¹	0.4 ¹	13/20 ¹	1685	1685	1360	2400
T 560/11	1100	950	BU 1800 H 1000	1400	3690	-	110	220 ¹	0.4 ¹	13/23 ¹	1685	1685	1530	2550
T 800/11	1100	950	BU 1800	1800	4750	-	140	240 ¹	0.4 ¹	15/25 ¹	1685	1685	1830	2800
								Cu	Cu					
T 10/13	1300	1150	A 70	20	-	70	16	47 ²	0.3 ²	5/8 ²	900	900	890	650
T 20/13	1300	1150	A 150	45	-	150	20	63 ²	0.3 ²	5/10 ²	980	980	890	780
T 40/13	1300	1150	A 300	90	-	300	26	84 ²	0.3 ²	5/12 ²	1050	1050	970	960
T 80/13	1300	1150	BU 200	200	-	650	50	190 ²	0.3 ²	5/15 ²	1150	1150	1030	1200

¹Al at 700 °C

²CuZn at 1000 °C

³The specified melting performances are maximum values. In practice, approx. 80 % are achieved. Values for other materials, e.g. zinc, on request.

⁴Depending on furnace design connected load might be higher

⁵External dimensions vary when furnace is equipped with additional equipment. Dimensions on request.

⁶ Values for other materials, e.g. zinc, on request



Bale-out of bale-out furnace with robot



Four side heating for excellent temperature uniformity



Manual ladling from a bale-out furnace T 80/10

Bale-Out Furnaces TB

Gas-Fired, for Melting and Holding

The gas-fired or oil-heated bale-out furnaces of the TB product lines provide for high melting performance. The use of modern burner systems, optimized pressures and flame guide in the furnace as well as the processing of high-quality insulation materials result in very low energy consumption.



Bale-out furnace TB 20/14

Standard Equipment for all Bale-Out Furnaces

- TB ../12 for aluminum and zinc alloys
- TB ../14 for copper alloys such as bronze or brass
- Modern and powerful two-stage burner for high melting capacity and low maintenance operation
- Fuel heating with either gas or oil
- Multi-layer insulation for optimum energy efficiency and low external wall temperatures
- Emergency outlet for safe discharge of the melt in case of a crucible break
- Integrated safety system which continues to operate the furnace at reduced power in case of malfunction in the thermocouple, in order to prevent the freezing of the melt
- Over-temperature limiter in furnace chamber for protection against overheating. The limiter switches the heating off when the set limit temperature is reached, and only switches it back on after the temperature has fallen again.
- Low-maintenance furnace chamber control with temperature measurement behind the crucible

Standard Equipment for Bale-Out Furnaces TB ../12

- Side exhaust gas discharge results in a high quality of the melt
- Swing lid

Standard Equipment for Bale-Out Furnaces TB ../14

- Insulation with an additional wear-and-tear layer made of copper-resistant refractory concrete
- Exhaust gas discharge over the crucible edge provides for high melting capacity
- Swinging collar plate for crucible pulling for bale-out furnaces to TB 10/14 - TB 20/14 (not possible for larger models)

Additional Equipment for Bale-Out Furnaces TB ../12

- Crucible breakage monitoring with optical and acoustic signal
- SMS-alarm message in case of crucible breakage
- Bath control system



Bale-out furnace TB 20/14 for bronze melting with side exhaust gas discharge and swiveling collar plate for crucible pulling



Bale-out furnace TB 20/14 in a pit with exhaust gas discharge over the crucible rime and swiveling collar plate for crucible pulling

Model	Tmax furnace °C	Tmax melt bath °C	Crucible	Capacity in kg			Burner output kW	Melting performance ^{3,5} in kg/h	Consumption melting ⁵ kWh/kg	Consumption holding kWh/h	Outer dimensions ⁴ in mm			Weight in kg
				Al	Zn	Cu					W	D	H	
TB 80/12	1200	1050	BU 200	200	520	-	180	140 ¹	1.3 - 1.5 ¹	10	1200	1870	1240	900
TB 100/12	1200	1050	BU 250	250	660	-	180	140 ¹	1.3 - 1.5 ¹	11	1310	1980	1380	1000
TB 110/12	1200	1050	BU 300	300	790	-	210	150 ¹	1.3 - 1.5 ¹	13	1310	1980	1510	1200
TB 150/12	1200	1050	BU 350	350	920	-	300	220 ¹	1.3 - 1.5 ¹	15	1310	1980	1550	1400
TB 180/12	1200	1050	BU 500	500	1320	-	300	270 ¹	1.3 - 1.5 ¹	17	1450	2140	1560	1700
TB 240/12	1200	1050	BU 600	600	1580	-	390	330 ¹	1.3 - 1.5 ¹	19	1490	2180	1700	1900
TB 360/12	1200	1050	BN 800	800	2110	-	400	350 ¹	1.3 - 1.5 ¹	20	1590	2280	1800	2000
TB 400/12	1200	1050	BN 900	900	2370	-	400	350 ¹	1.3 - 1.5 ¹	22	1590	2280	1900	2100
TB 500/12	1200	1050	BU 1210	1200	3160	-	400	350 ¹	1.3 - 1.5 ¹	23	1690	2380	1850	2300
TB 600/12	1200	1050	BU 1310	1300	3430	-	500	420 ¹	1.3 - 1.5 ¹	25	1690	2380	2000	2400
TB 650/12	1200	1050	BP 1000	1400	3690	-	500	420 ¹	1.3 - 1.5 ¹	26	1760	2450	1630	2300
TB 700/12	1200	1050	BU 1510	1500	3960	-	500	420 ¹	1.3 - 1.5 ¹	28	1690	2380	2120	2600
TB 800/12	1200	1050	BU 1800	1800	4750	-	500	440 ¹	1.3 - 1.5 ¹	30	1760	2450	2100	2800
								Cu	Cu	Without lid				
TB 10/14	1400	1250	A 100	-	-	100	210	90 ²	1.0 - 1.3 ²	16	980	1590	1190	1000
TB 20/14	1400	1250	A 150	-	-	150	210	100 ²	1.0 - 1.3 ²	17	1080	1870	1310	1250
TB 40/14	1400	1250	A 400	-	-	400	300	300 ²	1.0 - 1.3 ²	23	1210	2000	1460	1500
TB 60/14	1400	1250	A 500	-	-	500	320	320 ²	1.0 - 1.3 ²	26	1210	2000	1510	1600
TB 80/14	1400	1250	A 600	-	-	600	320	320 ²	1.0 - 1.3 ²	29	1260	2050	1540	1750

¹Al at 700 °C

²CuZn at 1000 °C

³The stated melting performances are maximum values. Daily operation comes up to roughly 80 %.

⁴External dimensions vary when furnace is equipped with additional equipment. Dimensions on request.

⁵ Values for other materials, e. g. zinc, on request



Thermocouple for melt bath control



Emergency outlet for safe melt discharge in case of crucible break



Bale-out furnace TB 240/12 with lateral exhaust gas discharge

Bale-Out Furnaces TBR with Recuperative Burner Gas-Fired, for Melting and Holding

The fuel-heated crucible furnaces in the TBR product line fitted with the side exhaust gas discharge provide for optimum energy utilization combined with highest quality melt. Fitted with a burner system including heat-recovery system using a recuperative burner, the energy efficiency of ordinary fuel-heated melting furnaces is significantly improved.

Depending on utilization the hot exhaust gases from the crucible furnace are guided through a heat exchanger in order to preheat the combustion air for the burner. The system provides for energy savings of up to 25 % compared to ordinary fuel-heated furnaces with side exhaust gas discharge. The higher purchase costs are amortized within a short time.

Standard Equipment as TB Models, but

- Heat exchanger in the exhaust gas duct to preheat the combustion air for the burners
- Energy savings of up to 25 % in comparison to other fuel-heated melting furnaces featuring side-wall exhaust gas vents
- Maximum furnace chamber temperature 1100 °C, for melt bath temperatures up to 950 °C
- Required min. gas pressure with full load: 70 mbar
- Only gas firing possible, no oil
- Over-temperature limiter in furnace chamber for protection against overheating. The limiter switches the heating off when the set limit temperature is reached, and only switches it back on after the temperature has fallen again.
- Low-maintenance furnace chamber control with temperature measurement behind the crucible



Crucible furnace TBR 110/11

Model	Tmax furnace	Tmax melt bath	Crucible	Capacity in kg	Burner output	Melting performance ²	Consumption melting	Consumption holding lid closed
	°C	°C		Al		kg/h	kWh/kg	
TBR 80/11	1100	950	BU 200	200	180	140 ¹	1.0 - 1.1 ¹	8.0
TBR 100/11	1100	950	BU 250	250	180	140 ¹	1.0 - 1.1 ¹	8.8
TBR 110/11	1100	950	BU 300	300	210	150 ¹	1.0 - 1.1 ¹	10.4
TBR 150/11	1100	950	BU 350	350	240	220 ¹	1.0 - 1.1 ¹	12.0
TBR 180/11	1100	950	BU 500	500	300	270 ¹	1.0 - 1.1 ¹	13.6
TBR 240/11	1100	950	BU 600	600	320	330 ¹	1.0 - 1.1 ¹	15.2
TBR 360/11	1100	950	BU 800	800	320	350 ¹	1.0 - 1.1 ¹	16.0

¹Al at 700 °C

²The stated melting performances are maximum values. Daily operation comes up to roughly 80 %.

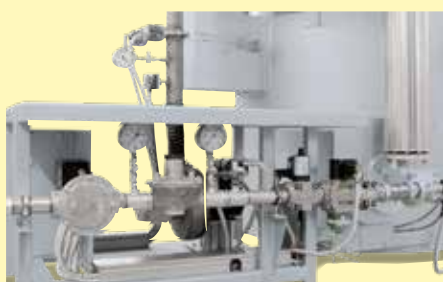

Burner with gas supply system



Heat exchanger in the exhaust gas duct



Two crucible furnaces TBR 100/11 in production

Transportable Bale-Out Furnaces TM

Electrically Heated, for Holding and Transport Aluminum

The transportable bale-out furnaces of the TM product lines were developed especially for use at different pouring locations. The cylindrical, very stable furnace housing, the very high-quality insulation and the meander-shape heating elements are the special features of this furnace family. The furnaces are designed to be transported by forklift truck and come with a plug-in connection to the control gear. With a forklift truck the furnace can be transported to the pre-melt furnace for filling. Due to the filling of the bale-out furnace directly at the premelting furnace, the otherwise necessary intermediate transport by means of a transport ladle and an additional filling process can be omitted. This has a positive effect on both energy efficiency and melt quality.



Transportable bale-out furnace TM 150/10

Standard Equipment

- Tmax 1000 °C, ideal for holding of aluminum alloys
- Cylindrical, highly stable furnace housing
- Damper slots under the furnace for safe forklift transportation of the furnace with the melt inside the foundry
- All-round heating provided by meander-shape heating elements
- Plug connection on the furnace for easy disconnection of the connecting cable to the switchgear
- Heating controlled using long-lasting solid-state-relays
- Insulation constructed in multiple layers with lightweight refractory bricks on the hot face
- Emergency outlet for safe discharge of the melt in case of a crucible break
- No exhaust gas vent necessary
- Crucible in standard design not included
- Over-temperature limiter in furnace chamber for protection against overheating. The limiter switches the heating off when the set limit temperature is reached, and only switches it back on after the temperature has fallen again.
- Low-maintenance furnace chamber control with temperature measurement behind the crucible

Additional Equipment like Models T see page 20

Model	Tmax furnace °C	Tmax melt bath °C	Crucible		Capacity in kg Al	Heating power in kW ²	Consumption holding Lid closed/open kWh/h ¹	Outer dimensions ³ in mm		
			Ø	H				W	D	H
TM 80/10	1000	800	BU 200		200	21	4/9	1000	1100	1150
TM 150/10	1000	800	875	600	350	36	5/10	1320	1440	1150
TM 240/10	1000	800	BU 600		600	42	7/15	1220	1340	1450
TM 310/10	1000	800	1170	580	770	42	8/17	1650	1730	1200

¹Al at 700 °C
²Depending on furnace design connected load might be higher
³External dimensions vary when furnace is equipped with additional equipment. Dimensions on request.



Forklift entry with dampers

Meander heating elements

Plug socket on the furnace for the cable connection to the switchgear and control box

Bale-Out Furnace TC

SiC-Rod-Heated, for Melting

The electrically heated bale-out furnaces of the TC product lines are characterized by a higher maximal temperature than achievable with wire heated melting furnaces. This allows for processing of demanding copper alloys such as aluminum bronze. These furnaces are designed for permanent operation at working temperatures.



Bale-out furnace TC 80/14

Standard Equipment

- Melt temperatures up to 1320 °C
- Symmetrical heating via powerful SiC rods
- Simple exchange of individual heating elements
- Heat operation by thyristors in phase-angle mode with performance control: The resistance of the SiC rods changes with temperature and age. Performance control ensures constant power of heating irrespective to the condition of the heating elements.
- Multi-layer insulation for optimum energy efficiency and low external wall temperatures
- Emergency outlet for safe draining of the melt in case of crucible breakage
- Exclusive use of insulation materials without categorization according to EC Regulation No 1272/2008 (CLP)
- Over-temperature limiter in furnace chamber for protection against overheating. The limiter switches the heating off when the set limit temperature is reached, and only switches it back on after the temperature has fallen again.
- Low-maintenance furnace chamber control with temperature measurement behind the crucible

Additional Equipment

- Additional heating transformers provide for significant reduction of the connected load
- Work platform for simplified loading
- Process control and documentation via Nabertherm Control Center (NCC) for monitoring, documentation and control see page 42
- For information on other accessories see page 38 - 39

Model	Tmax furnace °C	Tmax melt bath °C	Crucible	Capacity in kg	Heating power in kW ¹	Connected load in kW	Melting performance ³ in kg/h Cu	Outer dimensions ⁴ in mm			Weight in kg
				Cu				W	D	H	
TC 20/14	1450	1320	A 150	150	36	69	120 ²	1200	1250	930	830
TC 40/14	1450	1320	A 300	300	36	69	120 ²	1260	1250	1020	950
TC 80/14	1450	1320	BU 200	650	48	94	180 ²	1360	1350	1080	1050
TC 150/14	1450	1320	BU 300	1000	66	112	220 ²	1450	1320	1300	1300

¹Reduction of connected load by optional heating transformers

²CuZn at 1000 °C

³The specified melting performances are maximum values. In practice, approx. 80 % are achieved.

⁴External dimensions vary when furnace is equipped with additional equipment. Dimensions on request.



Switchgear with thyristors in phase angle operation for economic power consumption



Heated on both sides by high performance SiC rods

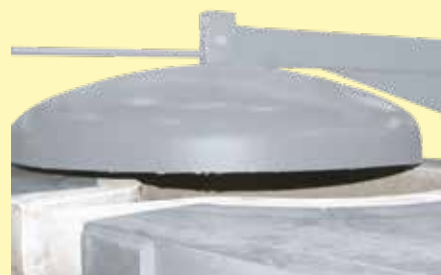

Swing lid with good sealing to collar plate to avoid heat loss over the crucible opening



Furnaces for Special Applications

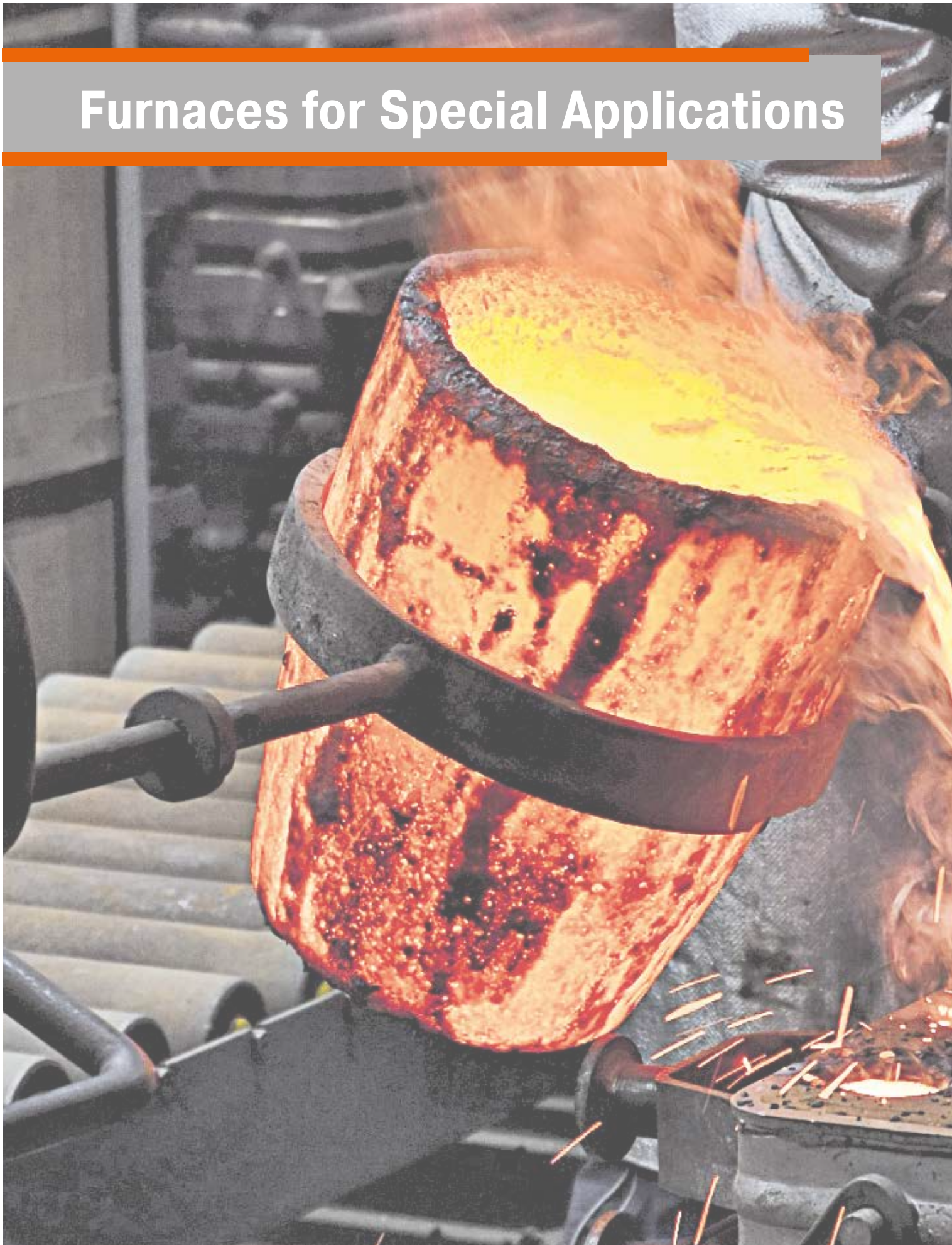



Furnace Group	Model	Page
Bath furnaces B	B	30
Laboratory tilting furnace K/KC	K/KC	31
Melting furnaces in customized dimensions		32
Cleaning furnace for riser tubes SRO	SRO	35

Bath Furnaces B

Electrically Heated, for Holding of Aluminum

The bath furnaces (without crucibles) have been especially developed for stationary holding operation in die-cast foundries with removal of the melt by a bale-out robot. The tub of the bath furnaces is lined with special long-life brick. The multi-layered backing insulation is designed for lowest electric connected load. The furnace tub is divided into three interconnected chambers. The heating proceeds from the lid into the center chamber. The bale-out openings are dimensioned to enable the robot to be optimally used. In holding operation bath furnaces, when used properly, provide better energy efficiency than bale-out furnaces.



Bath furnace B 120



Bath furnace B 500

Standard Equipment

- Perfectly suited for holding of aluminum
- Heating mounted in the lid, freely radiating from carrier tubes
- Particularly low energy consumption due to generously dimensioned, multi-layer insulation
- Exclusive use of insulation materials without categorization according to EC Regulation No 1272/2008 (CLP)
- Very high melt quality, among other things because the extraction basin is connected to the heated main basin only below the bath surface.
- Heating switched by low-maintenance solid-state-relays
- No exhaust gas discharge needed
- Temperature control/measurement in the melt and in the furnace chamber
- Useful only for holding, not for melting

Additional Equipment

- Adaptation to dosing pump
- Automated lid opening for ladling operation
- Ladle opening adapted to size of ladle

Model	Tmax furnace °C	Tmax melt bath °C	Capacity in kg	Heating power in kW ¹	Consumption holding kW h/h	Bale-out opening mm	Outer dimensions ² in mm			Weight in kg
			Al				W	D	H	
B 120	1000	750	300	11	2	300 x 300	1900	1150	1160	1900
B 250	1000	750	600	14	3	380 x 380	2030	1280	1200	2450
B 500	1000	750	1200	20	5	430 x 430	2350	1450	1240	3700

¹Depending on furnace design connected load might be higher

²External dimensions vary when furnace is equipped with additional equipment. Dimensions on request.



Inlet opening for filling with liquid aluminum



Melting thermocouple in the bath of the outlet opening



Heating mounted in the lid, simple replacement of the heating elements

Laboratory Tilting Furnaces K/KC Electrically Heated

These compact tilting furnaces for the melting of non-ferrous metals and alloys are one of a kind and have a number of technical advantages. Designed as tabletop models, they can be used for many laboratory applications. The practical counter balanced hinge with shock absorbers and the spout (not for KC 4/14) on the front of the furnace make exact dosing easy when pouring the melt. The melting furnaces are available for furnace chamber temperatures of 1000 °C, 1300 °C, or 1400 °C.



Tilting furnace KC 4/14

Standard Equipment

- Tmax 1000 °C, 1300 °C, or 1400 °C
- Crucible sizes of 0.75 liters, 1.5 liters or 3 liters
- Crucible with integrated pouring spout of clay-graphite included with delivery
- Additional spout (not for KC 4/14), mounted at the furnace for exact pouring
- Exclusive use of insulation materials without categorization according to EC Regulation No 1272/2008 (CLP)
- Compact bench-top design, simple emptying of crucible by tilting system with gas damper
- Crucible for heating up of melting furnace insulated with a hinged lid, lid opened when pouring
- Controller R7 (resp. 3508 for KC)

Additional Equipment

- Other crucible types available, e. g. steel
- Design as bale-out furnace without tilting device, e. g. for lead melting
- Over-temperature limiter for the furnace chamber with automatic reset to protect against overtemperature. The limit controller switches off the heating when the pre-set limit temperature has been reached and does not switch it on again until the temperature falls below the setting again.
- Observation hole for melt

Model	Tmax furnace °C	Tmax melt bath °C	Crucible	in kg		Volume in l	Outer dimensions ³ in mm			Connected load kW	Weight in kg
				Al	Cu		W	D	H		
K 1/10	1000	850	A6	1,5	-	0.75	600	710	670	3.0	85
K 2/10	1000	850	A10	3	-	1.50	600	710	670	3.0	90
K 4/10	1000	850	A25	7	-	3.00	670	800	710	3.5	110
K 1/13 ¹	1300	1150	A6	1,5	6	0.75	600	710	670	3.0	85
K 2/13 ¹	1300	1150	A10	3	10	1.50	600	710	670	3.0	90
K 4/13 ¹	1300	1150	A25	7	25	3.00	670	800	710	5.5	110
KC 1/14 ²	1400	1250	A6	-	6	0.75	570	630	580	11.0	90
KC 2/14 ²	1400	1250	A10	-	10	1.50	570	630	580	11.0	95
KC 4/14 ²	1400	1250	A25	-	25	3.00	670	870	590	22.0	110

¹Outer dimensions of furnace, transformer in separate housing (500 x 570 x 300 mm)

²Switchgear and controller mounted in a floor standing cabinet

³External dimensions vary when furnace is equipped with additional equipment. Dimensions on request.



Tilting-aid with dampers



Tilting furnace K 4/10 with steel crucible, e. g. for tin melting



Tilting furnace KC 1/14

Melting Furnaces in Customized Dimensions



Tilting furnace K 240/12 with lifting platform for charging and pouring at different levels

Tilting Furnaces with Electrohydraulic Lifting Platforms

Depending on the material flow and space requirements in a foundry, the charging height and pouring height may need to be different for a tilting furnace. For instance, if loading is performed at ground level and the metal is poured into a machine at a higher level, then an optional electro-hydraulic lifting platform can adjust for the difference. The operation of the lifting platform is by means of a 2 hand operation with a manual throttling valve. It can also be interlocked with other machinery and be motor driven operated.



Rotary table system with three bale-out furnaces T 150/11

Rotary Table System for Continuous Pouring

For continuous processes, multiple crucible furnaces can be combined on a rotary table system. For example, when using three furnaces with a rotation in 120° steps, loading takes place at the first space, de-gassing at the second space, and bale-out at the third. This ensures a continuous supply of liquid metal at the pouring location. The rotary table is designed with an emergency drain below in case of crucible breakage.



Electrically heated bale-out furnace for tin or lead with rim suction ring and melting bath thermocouple



Electrically heated bale-out furnace with steel crucible and swivel lid for tin or lead



Tilting furnace K 240/11 for melting of lead

Melting Furnaces for Heavy Metals

The melting furnaces in the K and T product lines can be upgraded with adapted electrical heating for melting of heavy metals like lead and zinc. The melting furnace is equipped with a special crucible, in most cases a steel crucible. The melting power is tailored to the type of metal to ensure optimum utilization of the melting furnace.



Rim suction ring for connection to customer's exhaust air system

Tilting furnace for heavy metals with bath control

Steel crucible with special suspension brackets for high charge weight



Tilting furnace K 1500/75 S for magnesium with 1500 liters crucible volume

Melting Furnaces for Magnesium

For a variety of projects, Nabertherm has supplied melting furnaces to be upgraded by the customer for the melting of magnesium. Nabertherm supplied the tilting furnace with all necessary control systems and the steel crucible. The melting furnaces were completed by the customer with the safety devices, the pump systems for bale-out, and gas supply systems.

Cleaning Furnace for Riser Tubes SRO Electrically Heated

Riser tubes for low-pressure melting furnaces must be cleaned in regular intervals. To remove deposits the pipe must be removed from the furnace and heated. In comparison to applying an open flame to heat the pipe, the SRO 170/1000/11 furnace offers the advantages of very uniform tube heating. The quality of the heat treatment is clearly better and the life-time of the risers can be extended when cleaned regularly. The heated rising tube can be removed from the furnace hot and returned to the low-pressure melting furnace.

The furnace is charged from above using a crane provided by the customer. Located in the lower section of the furnace is a steel catch drawer which is filled with sand or sizing compound. The rising tube hangs in the receptacle with a crane eye and the deposits drip into the drawer. Designed as a drawer, it can be easily pulled out, emptied and filled again.



Standard Equipment

- Tmax 1100 °C
- Charging opening with collar plate and swing lid on the furnace. Charging of the rising tube using the customer crane.
- Max. dimensions of the rising tube: Length: 1000 mm, outer dimension 90 mm with single-side flange with an outer diameter of 115 mm
- Exclusive use of insulation materials without categorization according to EC Regulation No 1272/2008 (CLP)
- Heated length: 1000 mm
- Charge receptacle with crane eye for holding smaller risers
- Steel catch draw, filled by the customer with sand, which collects deposits
- Steel collector designed as a drawer
- Furnace on rollers
- Switchgear and control equipment fastened directly to the furnace
- NTLLog Basic for Nabertherm controller: recording of process data with USB-flash drive

Additional Equipment

- Design for other riser dimensions on request
- Switchgear on rollers

Cleaning furnace SRO 170/1000/11 with suspended pipe

Model	Tmax °C	Outer dimensions ² in mm			Outer tube-Ø/ mm	Heated length/mm	Heating power in kW ¹	Electrical connection*
		W	D	H				
SRO 170/1000/11	1100	590	640	1700	90	1000	12,0	3-phase

¹Depending on furnace design connected load might be higher

²External dimensions vary when furnace is equipped with additional equipment. Dimensions on request.

*Please see page 43 for more information about supply voltage



To be pulled with crane eye for riser tubes with flange

Cleaning furnace SRO 170/1000/11

Steel collector designed as a drawer

Accessories and Process Control and Documentation



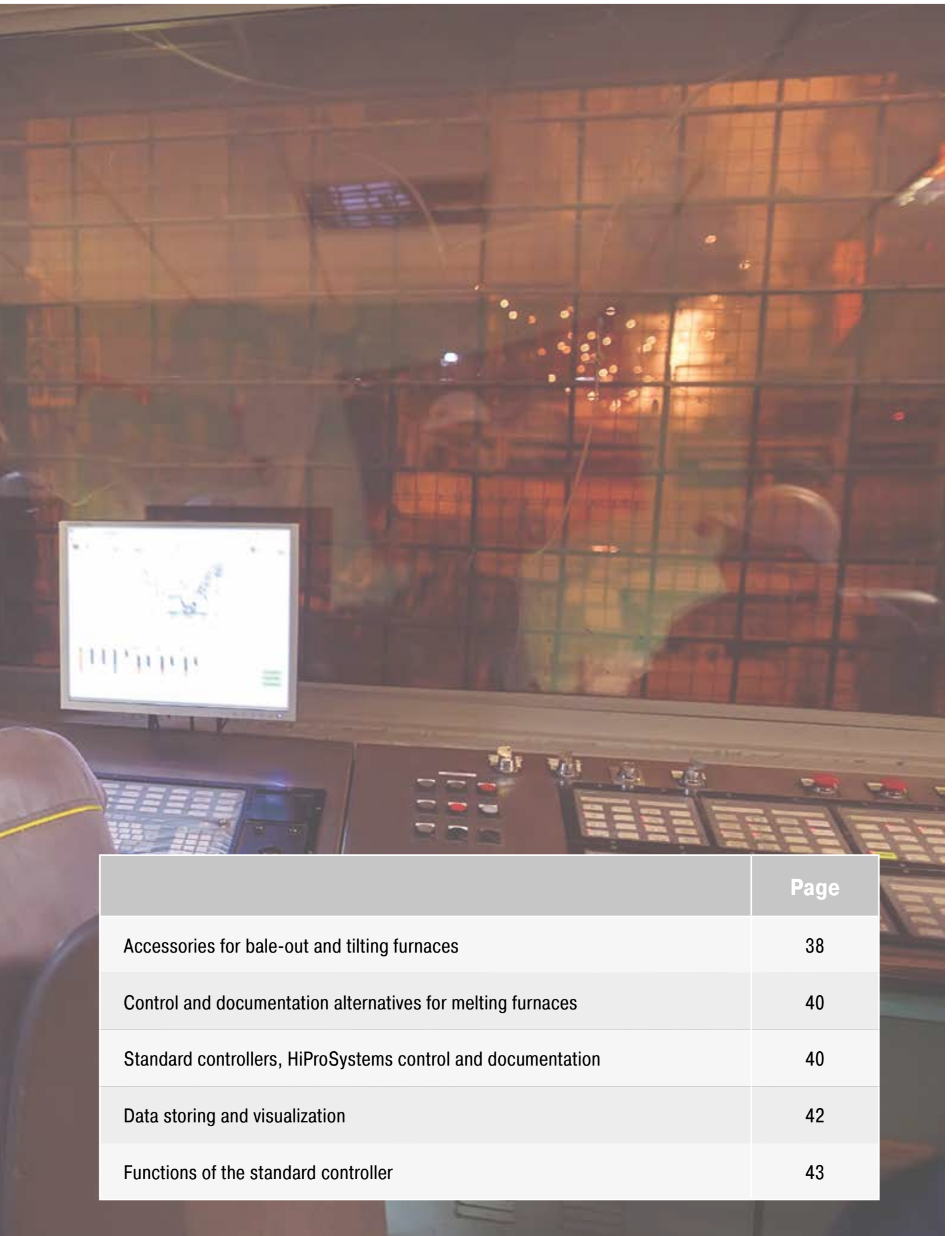

	Page
Accessories for bale-out and tilting furnaces	38
Control and documentation alternatives for melting furnaces	40
Standard controllers, HiProSystems control and documentation	40
Data storing and visualization	42
Functions of the standard controller	43

Accessories for Bale-Out and Tilting Furnaces

Our wide range of furnaces for the foundry can be extended individually for your application processes by our extensive range of accessories. For detailed information or for special requests, please contact us. With our long term experience and one of the largest engineering departments in the furnace industry, we would be very pleased to work with you and find a solution tailored to your needs.



Crucible Pulling Feature with swinging collar plate

Crucible Pulling Feature with Swinging Collar Plate

In standard version, Nabertherm crucible furnaces are built with a collar plate fixed to the furnace. The bale-out is done manually or by robot. As additional equipment, the smaller models up to T 40/.. can be equipped with a swinging collar plate which allows crucible pulling. To pull the crucible, the collar plate is swung to the side, so that the operator has free access to the crucible from above.

Charging Funnel for Ingots

The charging funnel made of stainless steel 1.4301 (304) makes charging the furnace much easier, especially when melting ingots. Long ingots can also be charged extending over the crucible edge, and then sink, guided, into the crucible. Furnaces which are designed with a control system with night-time reduction can, for example, be filled in the evening and, on the following morning a complete melt is ready for use. The funnel is suitable for all melting furnaces, electrically heated or gas- with a side exhaust gas discharge.



Charging funnel for ingots

Crucible Breakage Alarm Device for T(B).. /12 Models

Nabertherm melting furnaces are equipped with emergency outlet. In case of crucible breakage or leaking melt the crucible breakage alarm device will provide for a warning as soon as fluid metal emerges from the emergency outlet. The warning signal of the alarm is both optical, with a signal lamp, and acoustic, using a horn. As additional equipment it is possible to send an alarm as SMS-message to one or more mobile phones. One or more furnaces can be connected to the messaging device in parallel.



Crucible breakage alarm device under the emergency outlet of a melting furnace



Collecting Pan under the Emergency Outlet

The bale-out furnaces are standardly equipped with an inclined bottom and an emergency outlet for liquid metal in case of a crucible breakage. To collect the liquid melt in case of an emergency the models T .., TB .., K .. and KB .. can be delivered with a small base frame and a collecting pan. The pan can safely receive full crucible volume and is equipped with a pull-out handle. Unnecessary foundation works can be avoided.



Collecting pan under the emergency outlet

Work Platform for Loading for Bale-Out and Tilting Furnaces

For bale-out and tilting furnaces, customized work platforms for charging and servicing can be provided as additional equipment. This feature is used to simplify access to the furnace, particularly for larger furnace models. The operator has access to the top of the furnace to charge ingots or clean the melt.



Work platform for tilting furnace K 240/12

Pneumatic Lid Opener for Bale-Out Furnaces for Holding

The crucible furnaces of the T .. product lines can be equipped with an optional pneumatic lid opener. The pneumatic lid opener is activated by depressing a foot pedal. Optionally, the pneumatic lid opener can be controlled and triggered by an external signal to fully automate the ladling process. The furnace lid swings to the side and the operator has free access to the crucible. This practical feature increases energy efficiency because the furnace is only open during charging and bale-out. Over 50 % energy savings can be realized with the pneumatic lid opener vs. an always open furnace (see tables for energy consumption for each model of melting furnace, page 7).



Pneumatic lid opener

Control and Documentation Alternatives for Melting Furnaces

Nabertherm has many years of experience in the design and construction of both standard and custom control alternatives. All controls are remarkable for their ease of use and even in the basic version have a wide variety of functions



Eurotherm 3208 furnace controller

Furnace Control with Eurotherm 3208 or Eurotherm 3508 and Optional Weekly Timer

In the basic design, Nabertherm melting furnaces are equipped with Eurotherm 3208 or Eurotherm 3508 controllers. The temperature is measured inside the furnace behind the crucible. Two setpoints and one heating ramp can be set. For example, the setpoints could be the working temperature and the lower temperature for night setback. A digital weekly timer can also be used as an accessory which automatically switches between the two temperatures and the onoff function of the furnace. The switching times can be chosen for each working day.

Melt Bath Control (cascade control) via PLC and H500 Touch Panel or H700 Touch Panel for Bale-Out and Tilting Furnaces

In the basic design, the baleout and tilting furnaces are controlled with a thermocouple inside the furnace chamber behind the crucible. For fast heat-up times, the operator usually sets a temperature that is higher than the desired melt bath temperature. This control enables fast heating times but also results in temperature overshoots in the melt due to the indirect temperature measurement.



Weekly timer to switch between melting temperature and lower temperature

As in option the baleout and tilting furnaces can be equipped with a melt bath control. In addition to the furnace thermocouple, the temperature is also measured with a thermocouple in the melt. Both temperatures are permanently reconciled to achieve the exact melt bath temperature. If the melt bath thermocouple fails, the system automatically switches over to furnace control. This control considerably improves the quality of the melt because overshoots are effectively prevented. This type of temperature control is especially recommended for holding in order to control the melt bath temperature as precisely as possible. It is also the best choice for a quick and automatic melting process without any need for the operator to intervene in the temperature control during melting.

As an alternative to a thermocouple in the melt, a thermocouple in a pocket inside the crucible wall can also be used (special crucible with pocket required) which measures the temperature of the crucible wall. This indirect measurement is not as precise as measuring directly in the melt and automatic melting is slightly slower. However, the thermocouple is in a more protected position. This simplifies charging of the crucible and increases the thermocouple life time.

The melt bath is controlled via the H500 PLC-controls (electrically heated furnaces) with a 4 inch (optional 7 inch) touch panel and 4 operating buttons or the H700-controls (gasfired furnaces) with a 7 inch touch panel. It combines simple operation, precise control, and extensive user options. Presentation and program entry are done directly by a very simple to operate touch panel. The functions are displayed in plain text.

- Operation with furnace chamber control or melt bath control alternatively with cascade
- Display on a graphic color screen with overview of all temperatures
- Very easy data entry directly on the operating screen (touch panel)



H500

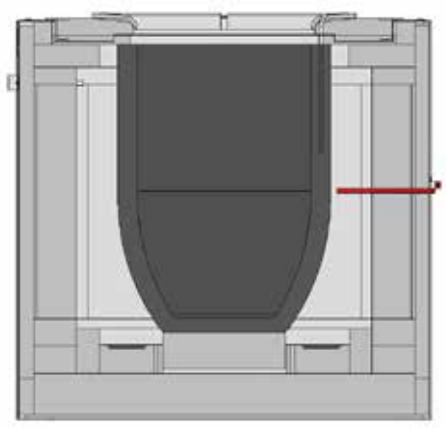

Furnace control

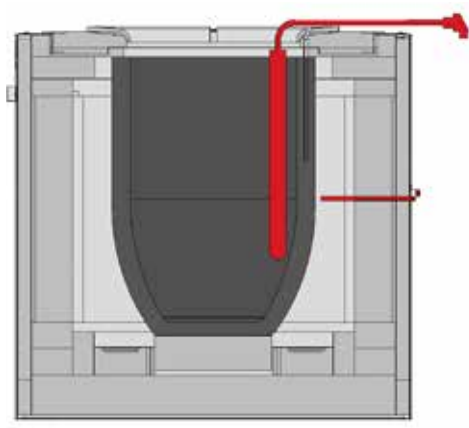

Melt bath control thermocouple in the melt

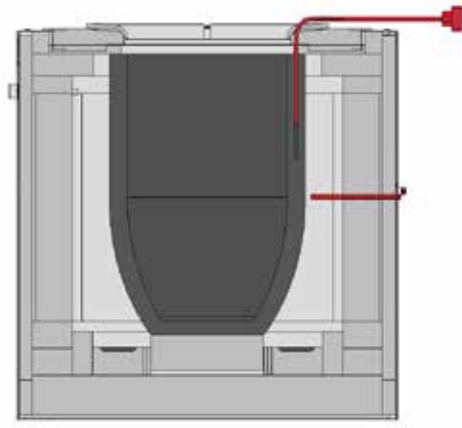

Melt bath control thermocouple in the pocket of the crucible wall

MO + TU SP 1-4		Nabertherm	
chamber	furnace	Monday	Tuesday
[id]	[id]	[business]	[business]
SP1	850	04:30:00	00:00:00
SP2	730	06:45:00	07:00:00
SP3	730	10:30:00	10:00:00
SP4	850	13:00:00	12:30:00

Entry of temperature/time programs in tabular format in several segments

- Weekly timer for changing temperatures, entries in real time
- A program with 12 segments can be set for each weekday
- Separate, freely programmable preparation program, password protected, e.g. to dry the crucible
- Band alarm with over and/or under temperature monitoring
- Operating hour counter
- Integrated safety system that continues furnace operation at reduced power in case of a fractured melt bath thermocouple to prevent the melt from solidifying
- Trend display of the furnace temperatures in the past 72 hours
- Language choice

Furnaces already in use can be retrofitted with a melt bath controller.

Bridging the Melt Bath Controls to Increase Melting Performance and Reduce Melting Times



Melt bath control with a thermocouple in the melt

If a completely empty crucible is to be refilled, the values measured by the melt bath thermocouple do not correspond to the actual temperature of the cold metals because the charge is not yet melted. A pushbutton is used to temporarily specify a higher furnace temperature than the program would adjust. The operator selects the desired time (max. 120 minutes) and the furnace temperature. When the time has expired, the controller automatically switches back to melt bath control.

Operation with Reduced Power

Operation with reduced power can be used to temporarily reduce the connected load of the furnace when the working temperature is reached. If reduced power is activated and the temperature in the furnace is within or above the set temperature band, part of the heating is switched off to operate the furnace with reduced power.

Other Possible Additional Functions

Band Alarm under/over Temperature

A band alarm displays the working range for casting. If the temperature is within the range, a green signal lamp is lit and the melt can be processed. In this range, the controller additionally provides for a signal that the customer can evaluate. Example: Release for the foundry robot.

Manual Program Intervention

If the current program is to be prolonged and the controller should not go to the next segment (e.g. continuation of melting operation in case of overtime), a key switch can be used to change over from program operation to controller operation. The controller continues working with the previously set temperature until the switch is activated again in order to continue with the program.



NTLog Comfort



NTLog Comfort for data recording of a Siemens PLC

Documentation with NTLog

For process documentation, the H500-controls can be equipped with NTLogComfort

With this extension, the process data can be stored in real time on a USB stick. No additional thermocouples or sensors are required. Only the data that is available in the controller is recorded. The CSV data can then be analyzed on a PC, either via NTGraph or via a customer-supplied spreadsheet program (e.g. MS Excel). In addition, a computer in the same local network can be connected via an Ethernet connection so that data can be written directly to this computer.

Documentation with NCC

The H700-controls can be supplemented with the Nabertherm Control Center Software (NCC) including PC. The NCC-controls provide for a convenient and comprehensive documentation of the melting operation with the following documentation options:

- All relevant data, such as furnace temperature, melt bath temperature, messages, etc. are always saved as a file each day
- The furnace is equipped with an additional start and stop button in a separate housing. When the button is pressed, the melt bath temperature is recorded separately and saved as a file. This enables customer charges to be analyzed and archived separately.
- In addition, the PC can also be used as an operator interface for several furnaces simultaneously
- NCC AA (Aviation and Automotive) for applications according to CQI9, AMS or NADCAP



User interface Control Center NCC based on PC

For more information on operating of the Nabertherm controllers, here are some tutorials:



Additional Equipment for All Electrically Heated Melting Furnaces

Multi-Step Switch for Reduction of Connected Rating



Multi-Step Switch

A multi-step switch switches off a part of the heating depending on the power of the corresponding furnace model. Generally, the furnace can be operated at full load for melting. If the furnace is only used in holding mode the connected rating of the furnace can be reduced by turning off a defined part of the heating capacity, resulting in a significant cost advantage. As an option, this function can be automatically switched depending on temperature.

Power Management for Reduction of the Electrical Connection Value

If several crucible furnaces are used the installation of an intelligent power management can be the right choice. Monitoring all furnaces the power management is continuously reconciling the switch-on times of the heating. This effectively prevents all furnaces from switching-on at the same time. The positive impact is that the total connected rating provided by the energy provider can be significantly reduced.

Switchgear Cooling with Fans or Air-Conditioning

The switchgear of our furnaces is designed for environment temperatures of up to 40 °C. To secure a failure-free and long lasting operation of the switchgear in case of higher temperatures they can be equipped with active fan cooling or even with an air-conditioner.

Controller Type Available for models	Eurotherm 3208		Eurotherm 3508		H700	
	TM/T/K	TB/TBR/KB/KBR	TC/KC	TC/TM/T/K/KC	TM/T/K	TB/TBR/KB/KBR
Functions						
Furnace control	●	●	●	●	●	●
Melt bath control				●	●	●
Weekly timer	○	○	○	●	●	●
Bridging the melt bath controller				○	○	○
Preparation program with 20 segments				●	●	●
Preparation program with a ramp	●	●	●			
Band alarm under/over temperature	○	○	○	●	●	●
Connection to an overriding system	○	○	○	○	○	○
Operation with reduced power	○			○	○	○
Operating hour counter	○	○	○	●	●	●
Documentation with NTLogComfort				○		
Documentation with NCC					○	○
Manual intervention in the program					○	○

● Standard
○ Option

Mains Voltages for Nabertherm Furnaces

1-phase: all furnaces are available for mains voltages from 110 V - 240 V at 50 or 60 Hz.

3-phase: all furnaces are available for mains voltages from 200 V - 240 V or 380 V - 480 V, at 50 or 60 Hz.

The connecting rates in the catalog refer to the standard furnace with 400 V (3/N/PE) respectively 230 V (1/N/PE).

Heat Treatment before and after Casting





	Seite
Tempering plants for aluminum and steel	46
Furnaces for continuous processes	48
Wax burnout	50
Additive manufacturing	52
Energy efficiency concepts	53

Tempering Plants for Aluminum and Steel

After casting, multi-stage heat treatment is often necessary. For processes such as the T6 heat treatment of aluminum (solution annealing, quenching and ageing) or the hardening of steel, quenching and tempering plants are used. Due to the design consisting of one or more furnaces in combination with a quenching tank or a cooling station, the quenching and tempering process can be carried out manually, semi-automatically or even fully automatically.



Drop-bottom furnace with fixed quenching bath

General Properties

- Multi-stage heat treatment of aluminum alloys and steel
- Manual, semi-automated or even fully automated
- Concepts for horizontal or vertical movement of the charge
- Quenching delay times from start of door opening of only 5 seconds possible
- Standard sizes and customized solutions available
- Process data acquisition and consideration of common automotive and aerospace standards such as CQI-9, AMS 2750 F

Horizontal Quenching and Tempering Plants

In horizontal quenching and tempering plants, the quench tank is positioned in front of the chamber furnace. The charge is transferred horizontally into the furnace by a 2-axis manipulator and, after heat treatment, is removed hot and quenched. As the movement technology in this plant concept is only in the hot furnace chamber for a short time, temperatures of up to 1300 °C are possible.

Drop-Bottom Furnace Plants

Drop-bottom furnaces are used for solution annealing and subsequent rapid quenching of aluminum alloys. Especially for thin-walled aluminum components, quenching delay times of only 5 seconds from the start of door opening to complete immersion in the quenching bath can be realized



Fully automatic drop-bottom furnace plant, consisting of two drop-bottom furnaces, movable water bath and several loading and unloading positions



Automatic quenching and tempering plant N 644/S

Customized Solutions

The modular design of our systems enables a wide range of design options for the plant and, with appropriate planning, also the possibility of later expansion.



Mobile drop-bottom furnace for solution annealing with pit-type furnace for artificial ageing with four parking places



For detailed information, please also see our catalog Thermal Process Technology.



Furnaces for Continuous Processes

For continuous processes with fixed cycle times, such as core or mold drying or for preheating molds in investment casting, continuous furnaces or rotary hearth furnaces are often the right choice. Depending on the process, different working temperatures, conveying concepts and heating concepts can be used here.

The conveyor technology is tailored to the required working temperature, geometry and weight of the charge and to the requirements regarding available space and integration into the process chain. The conveyor speed and the number of control zones are defined by the process specifications.



Gas-fired rotary-hearth furnaces for preheating of ceramic moulds up to 1100 °C incl. thermal post combustion for exhaust gas cleaning

Conveyor Concepts

- Conveyor belt
- Metal conveyor belt with adjusted mesh gauges
- Drive chain
- Roller conveyors
- Paternoster
- Pusher-type
- Rotary hearth

Heating Systems

- Electric heating, radiation or convection
- Direct or indirect gas-fired
- Infrared heating
- Heating with the use of external heat sources



Continuous belt furnace D 1000/4000/140/35 AS for black wash drying on sand cores



Continuous pilgrim step furnace system NBI 70000/15HAS for black wash drying on sand cores



Cycle push-through plant for artificial ageing of aluminum castings

Basic Configuration Criteria

- Conveyor speed
- Temperature uniformity
- Operating temperature
- Process curve
- Work space width
- Charge weights
- Cycle time or throughput
- Length of charge and discharge zone
- Generated exhaust gases
- Specific industry standards such as AMS, CQI-9, FDA etc.
- Other individual customer requirements



For detailed information, please also see our catalog
Thermal Process Technology.



Wax Burnout

For casting with lost patterns, among other things, furnaces are needed to get the pattern material out of the mold in a safe way and to fire the mold. Nabertherm also offers different solutions for this.



Dewaxing furnace N 300/WAX

Dewaxing Furnaces, Electrically Heated

These furnaces are specially designed for lost wax melting with subsequent firing of the ceramic mold. The electrically heated models are operated below the flash point of the wax for lost wax melting. The furnaces have a heated outlet in the bottom of the furnace chamber, which tapers to the center in a funnel shape. Below the furnace is a sealed stainless steel container with a removable drawer in which the wax is collected. After completion of the melting out process, the furnace continues to heat up to fire the molds.



Dewaxing furnace NB 300/BOWAX

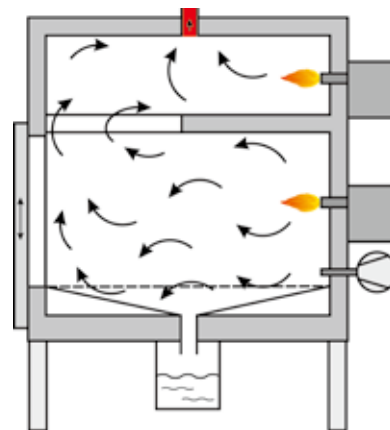

Dewaxing Furnaces, Gas-Fired

The chamber furnaces of the NB .. BOWAX are suitable for flash-fire processes in which the hot furnace is loaded with casting screws. For fast loading and unloading, the furnace is equipped with a pneumatic lift door. After loading, the wax liquefies in a very short time. The first part of the outflowing wax runs via the integrated pan directly into a collecting basin under the furnace and is safely collected in a water basin. The remaining part of the wax evaporates in the furnace chamber and is safely burned in the downstream thermal afterburning.



Chamber furnace N 650/14 BO with ignition burner

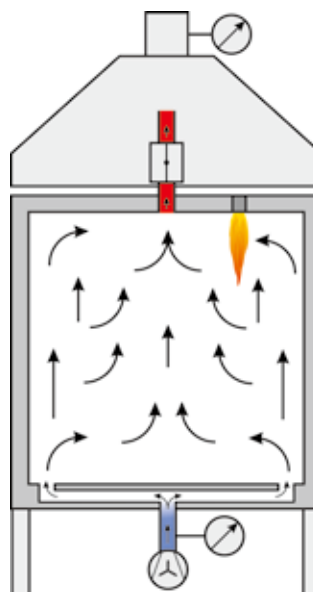

Burnout of Residual Wax or 3D-Printed Plastic Models

The chamber furnaces of the series N(B) .. BO are used for processes with high organic quantities or high evaporation rates. For safety reasons, they have an integrated pilot burner for ignition of the flammable components in mixed gases. An accumulation of ignitable components is avoided and safe burning is ensured. These furnaces can be used for residual dewaxing of casting screws or burnout of 3D-printed plastic models with subsequent sintering of the mold.



Chamber furnace N 650/14 BO



For detailed information, please also see our catalog Advanced Materials.



Additive Manufacturing



Retort furnace NR 150/11 for annealing of metal parts of 3D-printing



Oven TR 240 for drying of powders



Chamber oven KTR 2000 for curing after 3D-printing



Compact tube furnace for sintering or annealing under protective gases or in a vacuum after 3D-printing



HT 160/17 DB200 for debinding and sintering of ceramics after 3D-printing

Additive manufacturing allows for the direct conversion of design construction files fully functional objects. With 3D-printing objects from metals, plastics, ceramics, glass, sand or other materials are built-up in layers until they have reached their final shape.

Depending on the material, the layers are interconnected by means of a binder system or by laser technology.

Many methods of additive manufacturing require subsequent heat treatment of the manufactured components. The requirements for the furnaces for heat treatment depend on the component material, the working temperature, the atmosphere in the furnace and, of course, the additive production process.

Nabertherm offers solutions from curing for conservation of the green strength up to sintering in vacuum furnaces in which the objects of metal are annealed or sintered.

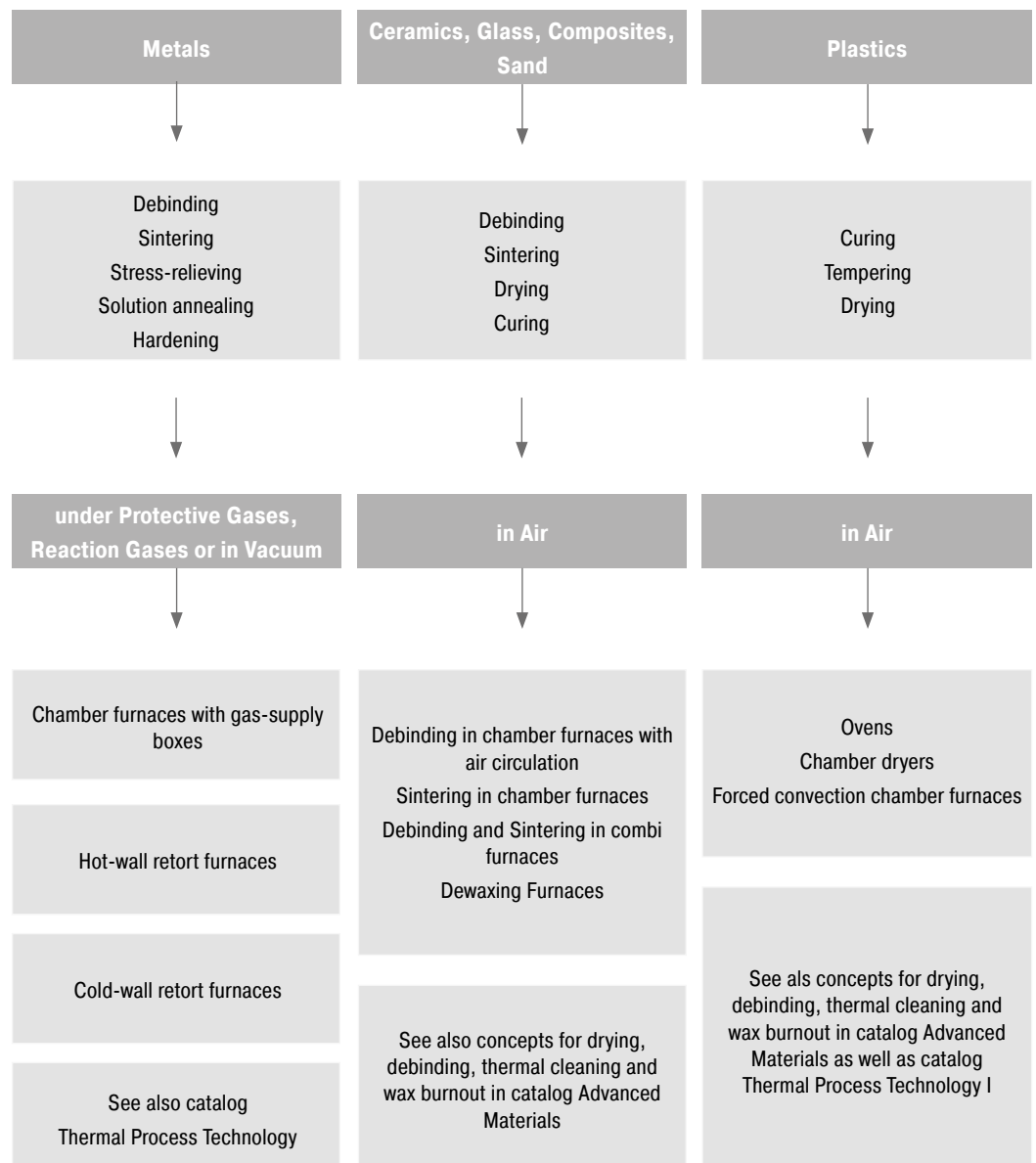

Also, concomitant or upstream processes of additive manufacturing require the use of a furnace in order to achieve the desired product properties, such as heat treatment or drying the powder.

Energy Efficiency Concepts



Counterflow heat exchanger for the forced convection chamber furnace N 2560/26 ACLS

In face of rising energy prices and stricter environmental regulations there is increasing demand for heat treatment plants with greater energy efficiency.

Depending on the furnace size and the process there is always a certain amount of potential energy which can be recovered from the waste heat and re-used. This is especially true for large furnace systems or long process times which allow for huge energy savings that the additional investment has a short pay-back time. The thermal energy from finished charges can also be used to pre-heat cold charges which is also an efficient way of saving energy.

The following examples outline engineering alternatives for heat recovery:

Heat Exchangers



Recuperator burner for aluminum melting furnace 16 x TBR 110/12 and 2 x TBR 180/12

The principle of the counterflow heat exchanger is to use the hot exhaust gas coming from the furnace to pre-heat the cold fresh air channelled into the furnace. In many cases, there is no need anymore for a separate fresh air preheating unit. Such a system is recommended if the process requires continuous air exchange in the furnace chamber, such as when tempering silicone, or during drying processes that are covered by the EN 1539 industrial standard.

Recuperator Burners

Large gas-heated heat-treatment furnaces are especially advantageous for the installation of recuperator burners. Recuperator burners also use hot exhaust gas; to pre-heat the combustion air. Depending on the furnace model and the process, substantial energy savings of as much as 25% can be realized by using recuperator burners so that there is a short pay-back time for the additional purchase costs.

Heat Transfer Chambers



Heat transfer between a hot and a cold charge

Heat transfer chambers, which can also be described as cooling/heating chambers, offer two enormous advantages. For one, they help save energy, and for another, using a heat transfer chamber increases productivity.

The load is removed from the furnace while it is still hot and placed in the heat transfer chamber. The chamber also has room for a new, cold charge. Circulating the air cools the hot charge and, at the same time, preheats the cold charge before it is put into the furnace. Consequently, the furnace heating does not have to provide the thermal energy and through-put capacity of the furnace is increased of the same time.

The above systems for enhancing energy efficiency are only a few examples of technical alternatives. We would be happy to advise you on whether an additional heat recovery module would also be a sensible add-on to your furnace or system.



Production system, consisting of four chamber furnaces for moving the load during heat treatment along with a three-stage heat exchanger to optimize energy efficiency



Spare Parts and Customer Service – Our Service Makes the Difference

For many years the name **Nabertherm** has been standing for top quality and durability in furnace manufacturing. To secure this position for the future as well, Nabertherm offers not only a first-class spare parts service, but also excellent customer service for our customers. Benefit from more than 70 years of experience in furnace construction.

In addition to our highly qualified service technicians on site, our service specialists in Lilienthal are also available to answer your questions about your furnace. We take care of your service needs to keep your furnace always up and running. In addition to spare parts and repairs, maintenance and safety checks as well as temperature uniformity measurements are part of our service portfolio. Our range of services also includes the modernization of older furnace systems or new linings.

The needs of our customers always have highest priority!



- Very fast spare parts supply, many standard spare parts in stock
- Worldwide customer service on site with its own service points in the largest markets
- International service network with long-term partners
- Highly qualified customer service team for quick and reliable repair of your furnace
- Commissioning of complex furnace systems
- Customer training in function and operation of the system
- Temperature uniformity measurements, also according to standards like AMS 2750 F (NADCAP)
- Competent service team for fast help on the phone
- Safe teleservice for systems with PLC controls via modem, ISDN or a secured VPN line
- Preventive maintenance to ensure that your furnace is ready for use
- Modernization or relining of older furnace systems

Contact us:

Spare parts

✉ spares@nabertherm.de

☎ +49 (4298) 922-474

Customer service

✉ service@nabertherm.de

☎ +49 (4298) 922-333



The whole World of Nabertherm: www.nabertherm.com

Please visit our website www.nabertherm.com and find out all you want to know about us - and especially about our products.

In addition to current information and exhibition dates, there is of course the possibility of direct contact or an authorized dealer from our worldwide dealer network.

Professional Solutions for:

- Thermal Process Technology
- Additive Manufacturing
- Advanced Materials
- Fiber Optics/Glass
- Foundry
- Laboratory
- Dental
- Arts & Crafts

Headquarters:

Nabertherm GmbH

Bahnhofstr. 20
28865 Lilienthal, Germany
Fon +49 4298 922 0
contact@nabertherm.de

Sales Organisation

China

Nabertherm Ltd. (Shanghai)
No. 158, Lane 150, Pingbei Road, Minhang District
201109 Shanghai, China
Fon +86 21 64902960
contact@nabertherm-cn.com

France

Nabertherm SARL
20, Rue du Cap Vert
21800 Quetigny, France
Fon +33 6 08318554
contact@nabertherm.fr

Great Britain

Nabertherm Ltd., United Kingdom
Fon +44 7508 015919
contact@nabertherm.com

Italy

Nabertherm Italia
via Trento N° 17
50139 Florence, Italy
Fon +39 348 3820278
contact@nabertherm.it

Switzerland

Nabertherm Schweiz AG
Altgraben 31 Nord
4624 Härkingen, Switzerland
Fon +41 62 209 6070
contact@nabertherm.ch

Benelux

Nabertherm Benelux, The Netherlands
Fon +31 6 284 00080
contact@nabertherm.com

Spain

Nabertherm España
c/Marti i Julià, 8 Bajos 7ª
08940 Cornellà de Llobregat, Spain
Fon +34 93 4744716
contact@nabertherm.es

USA

Nabertherm Inc.
64 Reads Way
New Castle, DE 19720, USA
Fon +1 302 322 3665
contact@nabertherm.com



All other Countries: Follow
<https://www.nabertherm.com/contacts>