

## Operating Instructions

### High-Temperature Furnaces (Tabletop Model)

LHT 02/16 - LHT 08/18

M01.1079 ENGLISCH

Original instructions

■ Made  
■ in  
■ Germany

[www.nabertherm.com](http://www.nabertherm.com)

---

### **Copyright**

© Copyright by  
Nabertherm GmbH  
Bahnhofstrasse 20  
28865 Lilienthal  
Federal Republic of Germany

Reg: M01.1079 ENGLISCH  
Rev: 2025-01

No responsibility is accepted for the correctness of this information. We reserve the right to make technical alterations.

<b>1</b>	<b>Introduction .....</b>	<b>5</b>
1.1	Key to the Symbols and Warning Terminology Used in Warning Messages .....	5
1.2	Product Description .....	8
1.3	Overview of the Complete System .....	10
1.4	Safeguarding against Dangers from Excess Temperatures .....	13
1.5	Key to the Model Names .....	14
1.6	Scope of Delivery .....	14
<b>2</b>	<b>Specifications .....</b>	<b>15</b>
<b>3</b>	<b>Warranty and Liability .....</b>	<b>17</b>
<b>4</b>	<b>Safety .....</b>	<b>18</b>
4.1	Defined Application .....	18
4.2	Requirements for the Furnace Operator .....	19
4.3	Requirements for the Operating Personnel .....	20
4.4	Protective Clothing .....	21
4.5	Basic Measures During Normal Operation .....	21
4.6	Basic Measures in Case of Emergency .....	22
4.6.1	What to Do in an Emergency .....	22
4.7	Basic Measures for Servicing and Maintenance .....	23
4.8	Environmental Regulations .....	23
4.9	General Risks with the Furnace .....	24
<b>5</b>	<b>Transportation, Installation and Initial Start-Up .....</b>	<b>25</b>
5.1	Delivery .....	25
5.2	Unpacking .....	27
5.3	Transport Securing Device/Packaging .....	28
5.4	Constructional and Connection Requirements .....	29
5.4.1	Installation (Furnace Location) .....	29
5.5	Assembly, Installation, and Connection .....	31
5.5.1	Installing the Exhaust Air Tube .....	31
5.5.2	Venting Exhaust Fumes .....	33
5.6	Air Inflow Lever .....	34
5.7	Connecting the Furnace to the Power Supply .....	35
5.8	Insertion of the Base Plate (Accessories) .....	37
5.9	Initial Start-Up .....	37
5.9.1	Molybdenum Disilicide (MoSi <sub>2</sub> ) Heating Elements .....	38
5.10	Loading/Charging .....	40
5.10.1	Stackable Sagger (Accessories) .....	41
<b>6</b>	<b>Operation .....</b>	<b>42</b>
6.1	Controller .....	42
6.2	Operation, Display and Switch Elements (depending on design) .....	43
6.2.1	Turning on the Controller/Furnace .....	43
6.2.2	Turning off the Controller/Furnace .....	43
<b>7</b>	<b>Servicing, Cleaning, and Maintenance .....</b>	<b>44</b>
7.1	Furnace Insulation .....	45
7.2	Shutting the System Down for Maintenance .....	45

7.3	Regular Maintenance of the Furnace .....	46
7.3.1	Regular Maintenance Tasks – Documentation .....	47
7.3.2	Regular Maintenance Tasks – Heating Elements/Furnace Chamber .....	47
7.4	Maintenance Table Key .....	48
7.5	Checking the Heating Element Screws .....	48
7.6	Cleaning Products .....	50
<b>8</b>	<b>Malfunctions .....</b>	<b>51</b>
8.1	Error Messages of the Controller .....	51
8.2	Warnings of the Controller .....	53
8.3	Malfunctions of the Switchgear .....	56
<b>9</b>	<b>Spare Parts/Wearing Parts .....</b>	<b>57</b>
9.1	Electrical Schematics/Pneumatic Schematics .....	58
9.2	Replacing a Heating Element .....	58
9.2.1	Tightening Torque for Screw Connections on Heating Elements .....	62
9.3	Replacing a Thermocouple .....	63
9.4	Replacement/Readjustment of the Door Insulation Structure .....	65
9.5	Fuse on the Outside of the Switchgear .....	66
9.6	Repairing the Insulation .....	68
<b>10</b>	<b>Accessories (Options) .....</b>	<b>68</b>
10.1	Gas Supply System (Accessories) .....	68
10.2	Operation of Compressed Gas Containers .....	70
10.3	Separate the Snap-In Coupling (Plug) from the Furnace Housing .....	71
10.4	Over-temperature Limit Controller .....	71
10.5	Electrical Schematics/Pneumatic Schematics .....	72
<b>11</b>	<b>Nabertherm Service.....</b>	<b>72</b>
<b>12</b>	<b>Shut-Down, Dismantling, and Storage.....</b>	<b>73</b>
12.1	Transportation/Return Transportation .....	73
<b>13</b>	<b>Declaration of Conformity .....</b>	<b>75</b>
<b>14</b>	<b>For Your Notes .....</b>	<b>77</b>

# 1 Introduction

These documents are intended only for buyers of our products and may not be copied or disclosed to third parties without our written consent. (Law governing copyright and associated protective rights, German Copyright Law from Sept. 9, 1965)

Nabertherm GmbH owns all rights to drawings, other documents and authorizations, also in case of applications for protective rights.

All the figures in the instructions have a descriptive character; in other words, they do not represent the exact details of the furnace.

## 1.1 Key to the Symbols and Warning Terminology Used in Warning Messages



### Note

The following operating instructions set forth specific warnings to highlight the residual risks that cannot be avoided when operating the equipment. These residual risks include hazards to personnel/product/equipment and the environment.

The symbols used in the operating instructions are primarily intended to draw attention to the safety instructions!

The respective symbols cannot replace the text contained in the safety instructions. The text must therefore always be read in full!

Graphic symbols correspond to **ISO 3864**. According to the **American National Standards Institute (ANSI) Z535.6** standard, the following warning messages and terminology are used in this document:



The general hazard symbol, in conjunction with the warning words **CAUTION**, **WARNING** and **DANGER**, warns of the risk of serious injury.

The textual explanations associated with the general hazard symbol, particularly if this appears on the device, must always be observed in order to obtain instructions on how to avoid hazards and prevent injury or death.

<b>NOTICE</b>	Indicates a hazardous situation leading to damage to or destruction of the equipment.
<b>CAUTION</b>	Indicates a hazardous situation that could result in minor or moderate injury.
<b>WARNING</b>	Indicates a hazardous situation that could result in death or serious or irreversible injury.
<b>DANGER</b>	Indicates a hazardous situation that will result in immediate death or serious injury.

### Warning Message Structure:

All warning messages are structured as follows

	<sup>1</sup> <b>WARNING</b> <sup>2</sup>
<sup>4</sup>	<ul style="list-style-type: none"> <li>• <b>Type and source of hazard</b><sup>3</sup></li> <li>• <b>Consequences of non-observance</b><sup>3</sup></li> <li>• <b>Action to avert hazard</b><sup>3</sup></li> </ul>

or

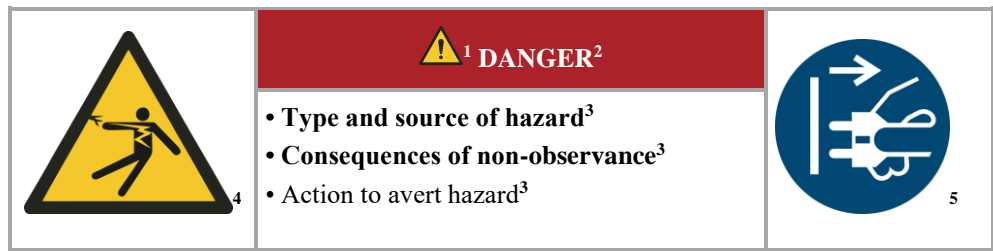

Item	Name	Explanation
1	Safety alert symbol	Indicates risk of injury
2	Signal word	Classifies the hazard
3	Safety messages	<ul style="list-style-type: none"> <li>• Type and source of hazard</li> <li>• Potential consequences if not observed</li> <li>• Measures/prohibitions</li> </ul>
4	Graphical symbols (optional) according to ISO 3864:	Consequences, measures or prohibitions
5	Graphical symbols (optional) according to ISO 3864:	Rules or prohibitions

### Information Symbols in the Instructions:



#### Note

Below this symbol you will find instructions and particularly useful information.



#### Rule - Rule Sign

This symbol draws attention to important rules that must be observed. Rule signs protect people against injury and show what is to be done in certain situations.



#### Rule – Important Information for Operators

This symbol draws the operator's attention to important information and operating instructions that must be observed.



#### Rule – Important Information for Maintenance Personnel

This symbol draws the maintenance personnel's attention to important operating and maintenance instructions (service) that must be observed.



#### Rule – Pull Out the Power Plug

This symbol tells the operator to pull out the power plug.

**Rule – Lift only with Several People**

This symbol draws the personnel's attention to the fact that this device may only be lifted and moved to its final destination by several people.

**Warning – Hot Surface, Do Not Touch**

This symbol warns the operator that the surface is hot and should not be touched.

**Warning – Danger from electric voltage**

This symbol warns the operator that there is a risk of an electric shock if the following warnings are ignored.

**Warning – Risk of Device Toppling Over**

This symbol tells the operator that there is a risk of the device toppling over if the following warnings are not heeded.

**Warning of suspended load**

This symbol warns the user of possible hazards from suspended loads. Working beneath a suspended load is strictly prohibited. Ignoring this can lead to fatal injury.

**Warning – Danger if heavy loads are lifted**

This symbol warns the operator of the potential dangers when lifting heavy loads. Ignoring this can lead to injury.

**Warning – Risk to the Environment**

This symbol warns the operator of the risk to the environment if the following information is not heeded. The operator must ensure that national environmental regulations are observed.

**Warning – Fire Danger**

This symbol warns operators of the danger of fire if the following information is not followed.

**Warning – Risk of Explosive Substances or Explosive Atmosphere**

These symbols warn the operator of explosive substances or an explosive atmosphere

**Warning – Danger from electromagnetic fields**

This symbol warns the user of possible hazards from electromagnetic fields. Magnetic fields can be a hazard for persons with metal parts or implants and for devices and data media.



### **Prohibited – Important Information for Operators**

This symbol warns the operator that water or cleaning products must NOT be poured over the objects. A high-pressure cleaning device must also not be used.

### **Warning Signs on the Furnace:**



### **Warning – Hot Surface, Danger of Burning – Do Not Touch**

You may not always realize that surfaces, such as furnace components, furnace walls, doors and materials, and even liquids are hot. Do not touch the surface.



### **Warning – Electrical voltage!**

Warning of dangerous electric voltage.

## **1.2 Product Description**

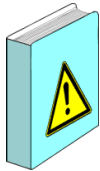

These electrically heated furnaces are a high-quality product which will give you many years of reliable service if they are properly cared for and maintained. One basic prerequisite is that the furnace is used the way it was designed to be used.

During development and production a high priority was placed on safety, functionality and economy.

Designed as tabletop models, these compact high-temperature furnaces have a variety of advantages. The first-class workmanship using high-quality materials, combined with ease of operation, make these furnaces all-rounders in research and the laboratory.

These high-temperature furnaces are also perfectly suited for the sintering of technical ceramics, such as zirconium oxide dental bridges.

### **Other Characteristics of this Product are:**

- Tmax 1600 °C, 1750 °C or 1800 °C
- High-quality heating elements made from molybdenum disilicide
- Furnace chamber lined with premium, durable fiber material, not classified
- Housing made of sheets of textured stainless steel
- Dual-shell housing with additional cooling for low external temperatures
- Space-saving design with lift door that opens upward
- Controlled fresh air opening
- Exhaust air opening in the top
- Thermocouples type B
- Switchgear with constant control of the heating elements
- Optimized for a working temperature range of 1000 °C to Tmax -100 °C
- NTLog for Nabertherm Controller: Process data recorded with a USB flash drive

### **Additional Equipment**

- Over-temperature limiter with manual reset as over-temperature protection for the furnace and the charge
- Manual or automatic gas supply system

- Protective gas connection to purge with non-flammable protective or reaction gases

**Accessories**

- Square saggar for charging of up to three layers
- Process control and documentation via VCD software package for monitoring, documentation and control

### 1.3 Overview of the Complete System

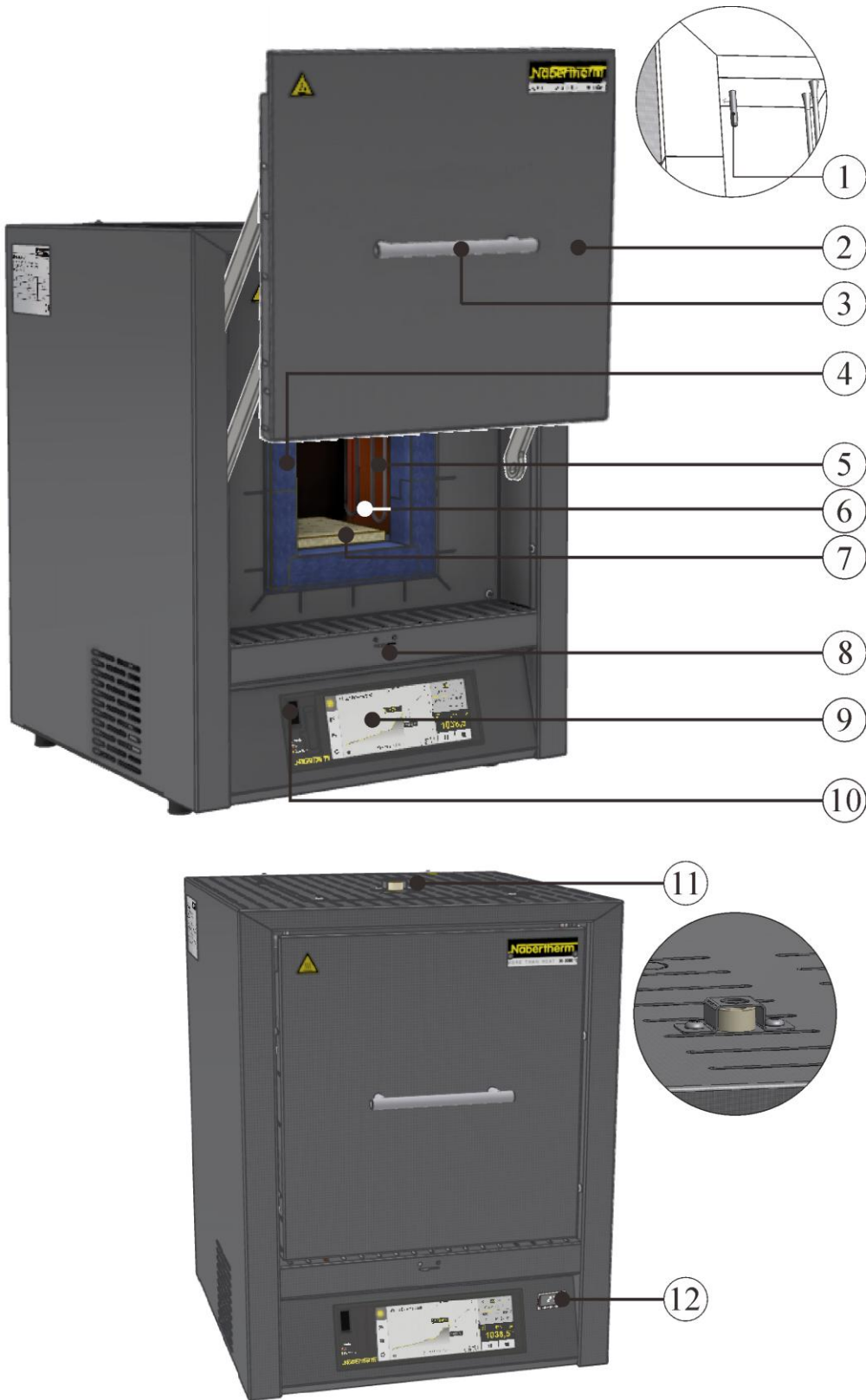

Fig. 1: High-temperature furnace (the figure shows a special design with over-temperature limiter) (similar to picture)

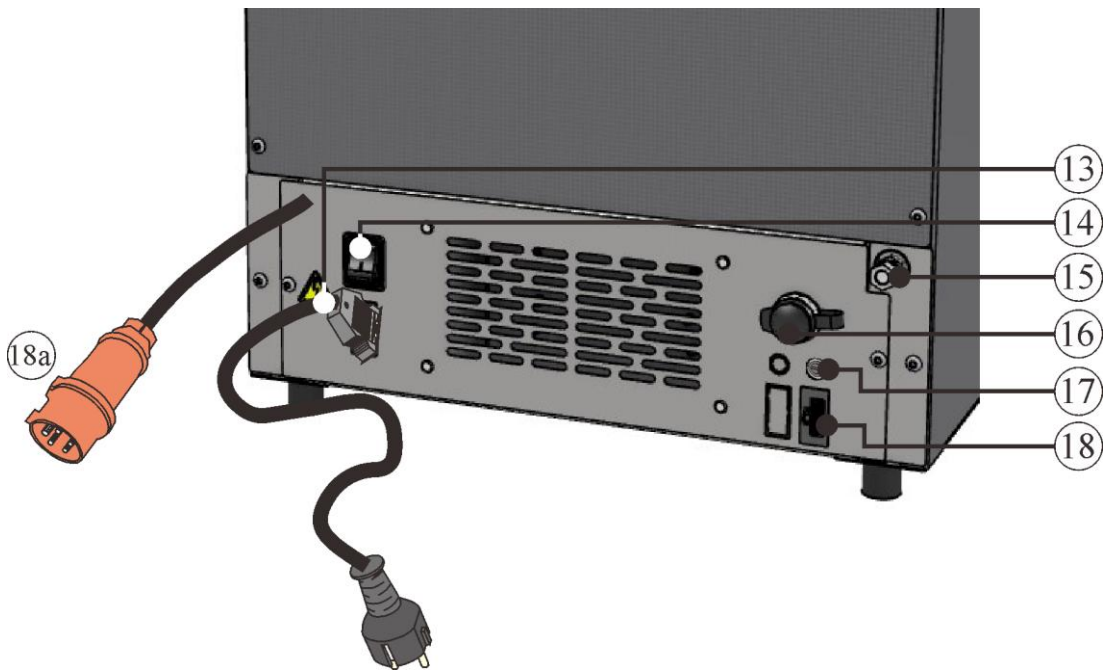

Fig. 2: High-temperature furnace – rear view (similar to picture)

No.	Name
1	Thermocouple
2	Lift door
3	Handle
4	Insulation made from non-classified fiber material
5	Heating elements made from molybdenum disilicide (MoSi <sub>2</sub> )
6	Furnace chamber
7	Floor plate (accessory)
8	Fresh-air flap to control fresh air
9	Controller
10	USB interface
11	Exhaust air tube
12	Over-temperature limiter with manual reset in accordance with DIN EN IEC 60519-1 as temperature limiter to protect the furnace and load (additional equipment)
13	Power plug with snap-in coupling (LHT 02/..)
14	Power switch with integrated fuse (for switching furnace on/off)
15	Protective gas connection for purging the furnace with non-combustible protective or reaction gases (additional equipment)
16	Additional power connection (for accessories)

No.	Name
17	Fuse for additional power connection (for accessories)
18	Ethernet interface (additional equipment)
18a	Power plug CEE (LHT 04/.. – LHT 08/..) (depending on supply voltage)

### Additional Equipment



Over-temperature limiter with manual reset in accordance with DIN EN IEC 60519-1 as temperature limiter to protect the furnace and load. The model can vary depending on the maximum furnace temperature.

Fig. 3: Example (similar to picture)

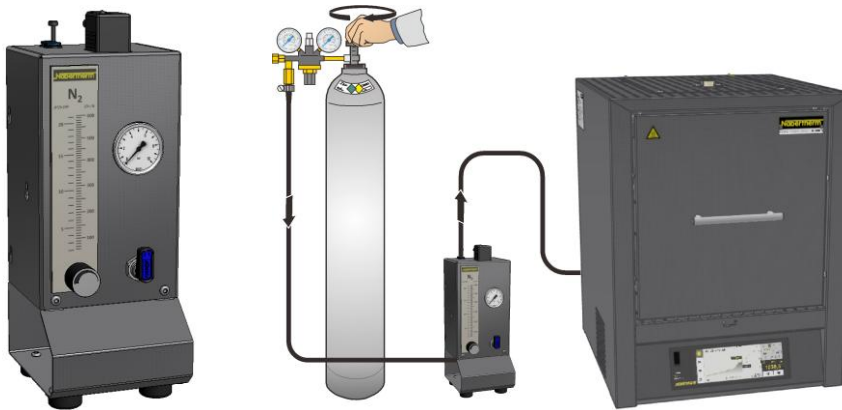

### Protective gas connection for non-flammable protective or reaction gases

Gas supply system for non-flammable protective and reaction gases with shut-off valve and flow meter with control valve, piped and ready to connect (similar to picture)

Fig. 4: Example (similar to picture)

### Accessories

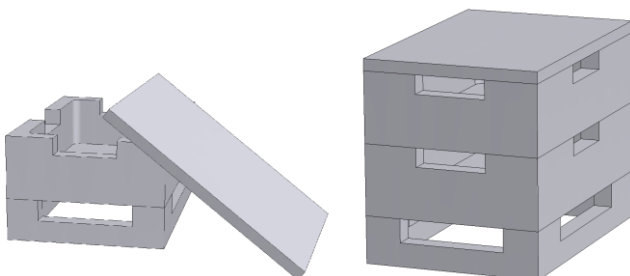

### Rectangular saggars



For optimum utilization of the furnace chamber, the material is placed in ceramic saggars. Up to three saggars can be stacked in the furnace. The saggars have slits to allow the air to circulate. The top sagger can be closed with a ceramic lid.

Fig. 5: Rectangular sagger with lid (similar to picture)

## 1.4 Safeguarding against Dangers from Excess Temperatures

Over-temperature limiters and over-temperature limiters with automatic reset to protect against over-temperature in the furnace are available for Nabertherm GmbH furnaces either as a standard feature (depending on the model series) or as additional equipment (customized design).

Over-temperature limiters and over-temperature limiters with automatic reset monitor the furnace temperature. The display shows the most recently set cut-off temperature. If the furnace temperature rises above the pre-set cut-off temperature, the heating is shut down to protect the furnace, the charge and/or the operating equipment.

	 <b>DANGER</b>
	<ul style="list-style-type: none"> <li>• <b>Danger caused by incorrectly entered cut-off temperature at the over-temperature limiter/over-temperature limiter with motor driven reset</b></li> <li>• <b>Risk of fatal injury</b></li> <li>• If, as a result of over-temperature from the charge and/or the operating equipment, a charge is likely to be damaged at this pre-set cut-off temperature of the over-temperature limiter/over-temperature limiter with motor driven reset, or if the charge itself becomes a source of danger for the furnace or its surroundings, the cut-off temperature must be reduced on the over-temperature limiter/over-temperature limiter with motor driven reset to the maximum permissible value.</li> </ul>

Read the operating instructions of the over-temperature limiter/over-temperature limiter with automatic reset before starting the furnace. The safety sticker must be removed from the over-temperature limiter/over-temperature limiter with automatic reset. When a change is made in the heat treatment program, the maximum permissible cut-off temperature (alarm trigger temperature) on the over-temperature limiter/over-temperature limiter with automatic reset must be checked or re-entered.

Depending on the physical characteristics of the furnace, we recommend that you set the maximum target temperature of the heating program in the controller between 5 °C and 30 °C below the trigger temperature of the over-temperature limiter/over-temperature limiter with automatic reset. This prevents unwanted triggering of the over-temperature limiter/over-temperature limiter with automatic reset.



Description and function, see the Operating Instructions of the over-temperature limiter/over-temperature limiter with automatic reset.

Fig. 6: Removing the sticker (similar to picture)

## 1.5 Key to the Model Names

Example	Explanation
LHT 02/16	LHT = Laboratory high-temperature furnace (tabletop model)
LHT 02/16	02 = 2-liter chamber volume (volume in L) 04 = 4-liter chamber volume (volume in L) 08 = 8-liter chamber volume (volume in L)
LHT 02/16	16 = Tmax 1600 °C 17 = Tmax 1750 °C 18 = Tmax 1800 °C

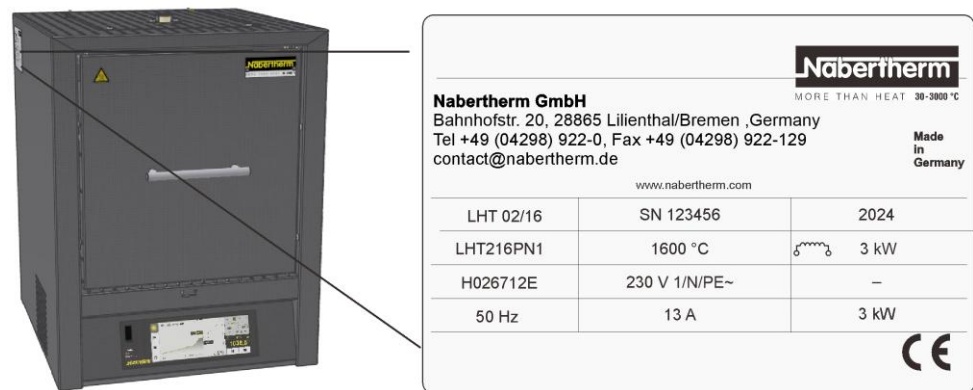











Fig. 7: Example: Model name (type plate)

## 1.6 Scope of Delivery

The scope of delivery includes:

	System components	Quantity	Comment
	High-temperature furnace LHT ...	1 x	Nabertherm GmbH
	Allen key	1 x	Nabertherm GmbH
	Exhaust air tube	1 x	Nabertherm GmbH
	Insulation block	1 x	Nabertherm GmbH
	Power cable <sup>1)</sup>	1 x	Nabertherm GmbH
	Stacking saggars (starter set) <sup>2)</sup>	1 x	Nabertherm GmbH
	Sintering bowl <sup>2)</sup>	4)	Nabertherm GmbH
	Tile <sup>2)</sup>		

	System components	Quantity	Comment
	Gas supply system <sup>1)</sup>	1 x	Nabertherm GmbH
	Process documentation for VCD software package <sup>2)</sup>	1 x	Nabertherm GmbH
	Other components, depending on model	- - -	See shipping documents
	Document type	Quantity	Comment
	Operating instructions for high-temperature furnace	1 x	Nabertherm GmbH
	Operating manual for controller	1 x	Nabertherm GmbH
	Operating manual for over-temperature limiter <sup>1)</sup>	1 x	Nabertherm GmbH
	Operating instructions for gas supply system <sup>2)</sup>	1 x	Nabertherm GmbH
	Operating instructions for VCD software package <sup>2)</sup>	1 x	Nabertherm GmbH
	Other documents, depending on model	1 x	

<sup>1)</sup> included with delivery depending on design/furnace model

<sup>2)</sup> included with delivery if required, see shipping documents

<sup>3)</sup> quantity depending on furnace model

<sup>4)</sup> quantity as required, see shipping documents



#### Note

Keep all documents for future reference. All functions of this furnace system were tested during manufacture and prior to shipping.



#### Note

The documents included do not always contain the electrical schematics and pneumatic diagrams.

If you need the respective diagrams, they can be ordered from Nabertherm Service.

## 2 Specifications



Electrical specifications are on the type plate located on the side of the furnace.

Model	Tmax	Inner dimensions in mm			Volume in L	Outer dimensions in mm			Connected load in kW	Weight in kg	Heating-up time <sup>1,2</sup> in min
		°C	w	d		h	W	D			
LHT 02/16	1600	130	145	130	2	430	450	570+325	max. 3.4	33	28
LHT 04/16	1600	160	175	160	4	450	475	610+335	max. 3.4	39	50

Model	Tmax	Inner dimensions in mm			Volume	Outer dimensions in mm			Connected load	Weight	Heating-up time <sup>1,2</sup>
LHT 08/16	1600	200	200	200	8	500	500	650+370	max. 6.7	47	33
LHT 02/17	1750	130	145	130	2	430	450	570+325	max. 3.4	33	46
LHT 04/17	1750	160	175	160	4	450	475	610+335	max. 3.4	39	90
LHT 08/17	1750	200	200	200	8	500	500	650+370	max. 6.7	47	50
LHT 02/18	1800	130	145	130	2	430	450	570+325	max. 3.4	33	56
LHT 04/18	1800	160	175	160	4	450	475	610+335	max. 3.4	39	106
LHT 08/18	1800	200	200	200	8	500	500	650+370	max. 6.7	47	60

<sup>1</sup>when connected to 230 V, 1/N/PE or 400 V, 3/N/PE (incl. saggar)

<sup>2</sup>to 100 °C below Tmax

<sup>3</sup>incl. open lift door

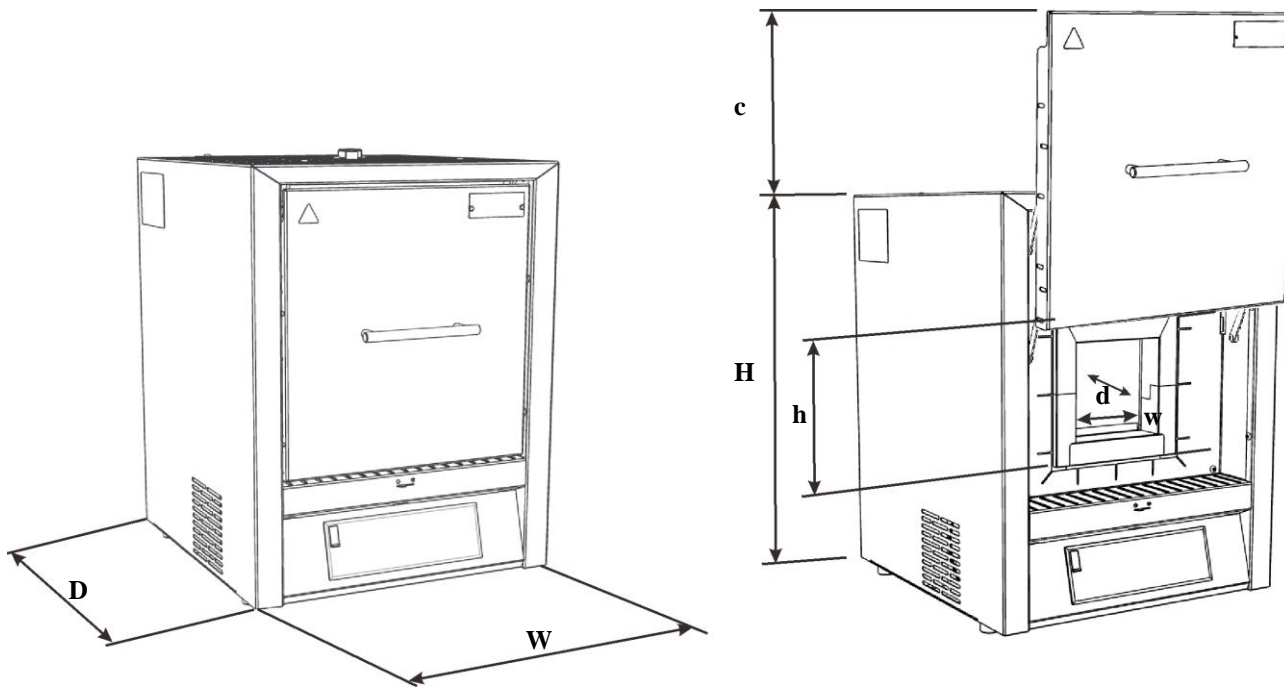

Fig. 8: Dimensions

Electrical connection		1-phase:	3-phase <sup>2</sup> :
	Model:	LHT 02/16 LHT 02/17 LHT 02/18	LHT 04/16-17-18 LHT 08/16-17-18
	Voltage:	208 V 220 V – 240 V	208 V 220 V – 240 V or 380 V – 415 V

Electrical connection		1-phase:	3-phase <sup>2</sup> :
	Frequency:	50 or 60 Hz	50 or 60 Hz
	Electricity		
Thermal protection class	Furnaces:	according to DIN EN IEC 60519-1	
Protection type	Furnaces	IP20	
Ambient conditions for electrical equipment	Temperature: Humidity:	+5 °C to 40 °C max. 80% non-condensing	
Weights	Furnace with accessories	Depending on design (see shipping documents)	

<sup>2</sup>Heating only between two phases

Emissions	Continuous sound pressure level	< 70 dB(A)
-----------	---------------------------------	------------

### 3 Warranty and Liability



**As regards warranty and liability, the normal Nabertherm warranty terms apply, unless individual terms and conditions have been agreed. However, the following conditions also apply:**

Warranty and liability claims for personal injury or damage to property shall be excluded if they are attributable to one or more of the following causes:

- All persons involved in operation, installation, maintenance, or repair of the furnace must have read and understood the operating instructions. No liability will be accepted for damage or disruption to operation resulting from non-compliance with the operating instructions.
- Not using the furnace as intended
- Improper installation, start-up, operation, or maintenance of the furnace,
- Operation of the furnace with defective safety equipment or improperly installed or non-functioning safety and protective equipment
- Not observing the information in the operating instructions with respect to transportation, storage, installation, start-up, operation, maintenance, or equipping the furnace
- Making unauthorized changes to the furnace
- Making unauthorized changes to the operating parameters
- Making unauthorized changes to the parameterization, the settings, or the program
- Nabertherm accepts absolutely no liability for damage caused by using parts that are not original Nabertherm parts. Original parts and accessories are designed especially for Nabertherm furnaces. Replace parts only with original Nabertherm parts. Otherwise the warranty will be void.
- Catastrophes due to third-party causes and force majeure

## 4 Safety

### 4.1 Defined Application



The Nabertherm furnace was designed and built in conformance with a careful selection of the applicable harmonized standards and other technical specifications. Hence, it corresponds to the state of the art and assures the greatest degree of safety.

Only materials whose characteristics and melting temperatures are known may be heated. Consult any available safety-related material data sheets.

- This furnace has been designed for commercial use in laboratories.
- Under certain circumstances gases or materials may be released from the materials in the furnaces that settle on the insulation or the heating elements and destroy them. **If applicable, read the labels and instructions on the packaging of materials that you use.**
- Furnaces with over-temperature limit controllers must have their shut-down temperatures set to prevent any overheating of the material.
- The set-up instructions and safety regulations must be followed, otherwise the furnace will be considered improperly used, effectively cancelling any claims against Nabertherm GmbH. The EC Declaration of Conformity will cease to be valid if any modifications are made to the machine without our approval.
- The set-up instructions and safety regulations must be followed, otherwise the furnace will be considered improperly used, effectively cancelling any claims against Nabertherm GmbH.
- Opening the furnace while it is still hot, over 200 °C (392 °F), can lead to increased wear of the following components: insulation, door seal, heating elements and furnace housing. No liability shall be accepted for any damage to the goods or the furnace resulting from non-compliance with this warning.

#### **Improper furnace operation:**

- Any other use, such as processing of products other than those for which the furnace was intended as well as handling hazardous materials or materials dangerous to health is deemed IMPROPER.
- Not for processes where explosive or flammable substances may form. (No applications according to EN 1539)



Operation with power sources, products, operating equipment, auxiliary materials, etc., which are listed as hazardous or which may in any way harm the health of the operator is prohibited.

The furnace must not be filled with materials or substances that release explosive gases or vapors. Only materials and substances whose properties are known may be used.

- Not permitted for heating foods or magnesium
- Not permitted for vaporizing substances containing hydrogen



This furnace was designed for **commercial** use. The furnace is **NOT** designed for heating food, animals, wood, grain, etc.  
 The furnace must not be used to heat the workplace.  
 Do not use the furnace to melt ice or for similar purposes.  
 Do not use the furnace as a clothes dryer.



**Note**

Continuous operation at maximum temperature can lead to increased wear of heating elements, insulation materials and metallic components. We recommend working at approx. **50 °C below maximum temperature**.



**For all furnace systems**

Operation with explosive gases or mixtures or explosive gases or mixtures formed during the process is prohibited.

**These furnace systems have no safety technology for processes in which combustible mixtures can form (design does not meet the safety requirements of EN 1539)**

The concentration of organic gases must at no time exceed 3% of the lower explosion limit (LEL) in the furnace. This requirement not only applies to normal operation, but also in particular to exceptional circumstances, such as process malfunctions (due to the breakdown of a unit, etc.).



**Note**

This product does **not** comply with the ATEX Directive and may **not** be used in ignitable atmospheres. The system must not be operated with explosive gases or mixtures and it must be ensured that explosive gases or mixtures do not form during the process.

## 4.2 Requirements for the Furnace Operator



The set-up instructions and safety regulations must be followed, otherwise the furnace will be deemed to have been used improperly, effectively cancelling any claims against Nabertherm GmbH.

This level of safety when operating the furnace can be achieved only if all the necessary measures have been taken. It depends on the furnace operator's diligence in planning these measures and controlling how they are carried out.

**The Operator must ensure that**

- all harmful gases are removed from the workplace, for example by an extraction system,
- the extraction system is switched on,
- the workplace is properly ventilated,
- the furnace is operated only in a perfect operating condition and, in particular, that the functions of the safety components are checked regularly.
- the required personal protective equipment is available for and used by the operating, maintenance, and repair personnel.
- these operating instructions, including the supplier documentation, are kept near the furnace. These instructions must be available at all times for anyone working with or on the furnace;

- all the safety and operating instruction signs on the furnace can be read properly. Damaged or unreadable signs must be replaced immediately,
- furnace personnel are informed regularly about all issues involving occupational safety and environmental protection and are familiar with all the operating instructions, especially those involving safety,
- a risk assessment is carried out (in Germany, covered of the Occupational Safety Act) to determine any other hazards that may result from the working conditions particular to the furnace's location,
- all other instructions and safety guidelines that have been determined in a risk assessment for the workplace are compiled in an operation manual (in Germany, covered of the Ordinance Regulating the Use of Operating Equipment).
- Only sufficiently qualified and authorized personnel may operate, maintain and repair the system. This personnel must be trained in how to operate the furnace and must confirm their participation in the training with a personal signature. The training program must be documented in detail. In case an operator is replaced, additional training must also take place. The additional training may only be performed by authorized, trained individuals familiar with the system. The additional training must be painstakingly documented and participation must be evidenced by the names and signatures of the participating employees.



**Note**

In Germany, the general accident protection guidelines must be observed. The accident prevention regulations applicable in the country where the furnace is installed must be observed.

### 4.3 Requirements for the Operating Personnel





All persons involved in operation, installation, maintenance, or repair of the furnace must have read and understood the operating instructions. No liability will be accepted for damage or disruptions to operation resulting from non-compliance with the operating instructions.

Only adequately qualified and authorized persons may operate, maintain, and repair the system.

These personnel are informed regularly about all issues involving occupational safety and environmental protection and are familiar with all the operating instructions, especially those involving safety,

Only trained personnel may operate the control and safety equipment.

	 <b>DANGER</b>
	<ul style="list-style-type: none"> <li>• <b>Danger caused by incorrectly entered cut-off temperature at the over-temperature limiter/over-temperature limiter with motor driven reset</b></li> <li>• <b>Risk of fatal injury</b></li> <li>• If, as a result of over-temperature from the charge and/or the operating equipment, a charge is likely to be damaged at this pre-set cut-off temperature of the over-temperature limiter/over-temperature limiter with motor driven reset, or if the charge itself becomes a source of danger for the furnace or its surroundings, the cut-off temperature must be reduced on the over-temperature limiter/over-temperature limiter with motor driven reset to the maximum permissible value.</li> </ul>

#### 4.4 Protective Clothing



Wear protective clothing



Wear goggles to protect your eyes.



Wear heat-resistant gloves to protect your hands.

#### 4.5 Basic Measures During Normal Operation



##### Risks during normal operation

Before switching the furnace on, check and ensure that only authorized persons are in the working area of the furnace and that no one can be injured as a result of operating the furnace.

Each time, before starting production check and ensure that all the safety equipment functions as intended (for example, that the contact safety switch switches the heating off when the lid is opened).

Before starting production each time, check the furnace for obvious damage and ensure that it is operated only in a perfect condition. Report any defects to Nabertherm Service immediately.

Before starting production each time, remove all materials and objects that are not needed for production from the working area.

**At least once every day (see also Servicing and Maintenance) check the following:**

- Check the furnace for obvious external damage (visual check), for example insulation, heating elements, power cable, exhaust gas system, if applicable.

- Check that all safety equipment is functioning (for example, that the contact safety switch switches the heating off when the door is opened).

## 4.6 Basic Measures in Case of Emergency

### 4.6.1 What to Do in an Emergency



#### Note

**The power plug is to be pulled out to stop the furnace in case of an emergency.**

Therefore, the power plug must be accessible at all times when the furnace is operating so that it can be pulled out quickly in case of an emergency.

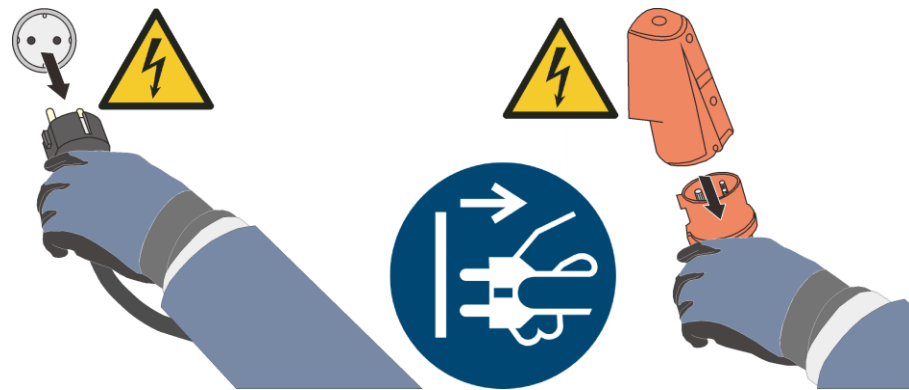

Fig. 9: Pull the power plug (similar to picture)



#### Risks during Normal Operation!

Switch the furnace off immediately in case of unexpected occurrences in the furnace (e.g. a lot of smoke or unusual smells). Wait until the furnace has cooled naturally to room temperature.

**In case of fire, keep the door and fresh-air lever closed. This prevents smoke spreading and oxygen entering the furnace.**





**Warning – Danger of Electric Shock!**

Work on the electrical equipment may be done only by qualified, authorized electricians.

## 4.7 Basic Measures for Servicing and Maintenance



Maintenance work must be performed only by authorized persons, observing the maintenance instructions and the accident prevention regulations. We recommend that maintenance and repair work be carried out by the service team of Nabertherm GmbH. Non-compliance may cause injuries, death, or considerable damage to property.

Switch off the system and make sure it cannot be switched on again inadvertently (lock the main switch and secure it with a padlock), or pull out the power plug.

Clear an adequate area around the system to facilitate the repair work.

Suspended loads are dangerous. Working beneath a suspended load is prohibited. There is a risk of fatal injury.

Relieve the pressure on hydraulic and pneumatic equipment before carrying out maintenance or repair work. (if applicable).

When cleaning furnaces, control cabinets, or electrical equipment housings, never spray them with water.

When maintenance or repair work has been completed, before recommencing production ensure the following:

- Check that loosened screw connections have been re-tightened,
- Reinstall protective equipment, screens, and filters,
- Remove all material, tools, and other equipment used for the maintenance or repair work from the working area of the system,
- Remove any liquids that have leaked,
- Check that all safety functions (e.g. EMERGENCY STOP button) work properly,
- Power cables may be replaced only with similar, approved cables

## 4.8 Environmental Regulations

All statutory duties regarding waste avoidance, proper recycling, and disposal must be observed when work is carried out on and with the furnace.

Problem materials that are no longer needed, such as lubricants or batteries, must not be placed in normal waste disposal systems or allowed to enter the sewage system.

During installation, repair, and maintenance work, substances that are hazardous to water, such as

- lubricating grease and oils
- hydraulic oils
- refrigerants
- solvent-based cleaning fluids must not be allowed to contaminate the soil or enter the sewage system.

These substances must be stored, transported, collected, and disposed of in suitable containers.



**Note**

The operator must ensure that national environmental regulations are observed.

When it is delivered, this furnace contains no substances that make a hazardous waste classification necessary. However, residues of process materials may accumulate in the furnace insulation during operation. These may be hazardous to health and/or the environment.

- Dismantle the electronic components and dispose of them as electric scrap.
- Remove the insulation and dispose of it as hazardous waste (see “Servicing, Cleaning, and Maintenance with Ceramic Fiber Material”).
- Dispose of the housing as scrap metal.
- Contact the responsible disposal company to dispose of the materials listed above.

## 4.9 General Risks with the Furnace



### Warning – General hazards!

Risk of burning on the furnace housing

The door handle can be extremely hot when the furnace is operating; wear protective gloves

Risk of crushing from moving parts (door hinges)

Dangerous high voltages are present at the control cabinet (if applicable) and at the terminal boxes on the system.

Do not insert objects into openings in the furnace housing, exhaust-air holes or cooling slits of the switchgear or furnace (if present). Ignoring this warning can result in electric shock.

### Risk of fire if using an extension cable:

For all furnace models with a plug-in connection:

If an extension cable is used, its maximum electrical load must not be exceeded. Do not operate the furnace with an extension cable if you are not sure if grounding is guaranteed. Power strips must never be used.





### Warning – General Hazards

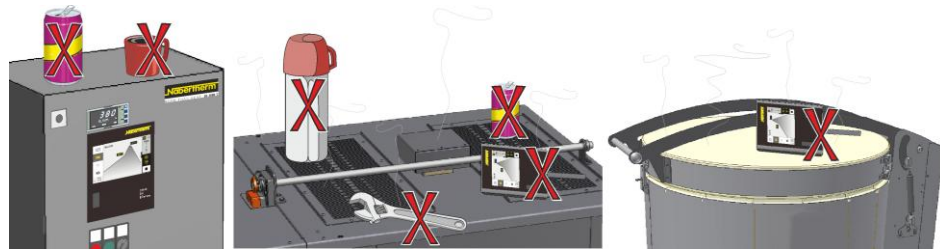

No objects may be placed or set down on the furnace or switchgear. There is a risk of fire or explosion.



### Warning – Influence on Implants from Electromagnetic Fields

It can be assumed that there is no risk from **electromagnetic fields**. Deviating from this, there may be a risk for people with active implants (such as a pacemaker, insulin pump) and passive implants, as the function of the implant may be affected also with a field strength below the permissible threshold. Proper function must be ensured on the basis of the technical specifications of the implant through an individual assessment by a suitable expert (for example, an occupational physician).

	 <b>DANGER</b>	
	<ul style="list-style-type: none"> <li>• <b>Danger from electrocution</b></li> <li>• <b>If there is no earth connection, or the earth connection is poorly connected, the result may be a deadly electrical shock.</b></li> <li>• Do not insert any metallic objects such as thermocouples, sensors or tools into the furnace chamber without having previously ensured that the plant has been correctly earthed. Entrust the job of making a earth connection between the object and the furnace housing to a qualified electrical technician. Any objects inserted into the furnace must be inserted only through those openings intended for this purpose.</li> </ul>	

	 <b>DANGER</b>
	<ul style="list-style-type: none"> <li>• <b>Danger caused by incorrectly entered cut-off temperature at the over-temperature limiter/over-temperature limiter with motor driven reset</b></li> <li>• <b>Risk of fatal injury</b></li> <li>• If, as a result of over-temperature from the charge and/or the operating equipment, a charge is likely to be damaged at this pre-set cut-off temperature of the over-temperature limiter/over-temperature limiter with motor driven reset, or if the charge itself becomes a source of danger for the furnace or its surroundings, the cut-off temperature must be reduced on the over-temperature limiter/over-temperature limiter with motor driven reset to the maximum permissible value.</li> </ul>

## 5 Transportation, Installation and Initial Start-Up

### 5.1 Delivery

#### Check that Everything is Complete

Compare the delivered items with the delivery note and the purchase order documents.

**Immediately** notify the carrier and Nabertherm GmbH of any missing or damaged parts, as complaints at a later date cannot be acknowledged.

#### Danger of Injury

When the furnace is being lifted, parts of the furnace or the furnace itself could topple over, slip, or fall. Before the furnace is lifted, make sure no one is in the working area. Wear safety footwear and a hard hat.

#### Safety Instructions

- Forklifts must be operated only by authorized personnel. The operator bears sole responsibility for safe operation and the load
- When the furnace is being lifted, make sure that the ends of the forks or the load do not catch on neighboring goods. Use a crane to move tall parts, such as control cabinets.

- Use only lifting equipment with sufficient load-bearing capacity
- Lifting gear must be attached only to positions that have been designated for this purpose
- Attachments, piping, or cable conduits must never be used to affix lifting gear
- Unpackaged parts should only be lifted with ropes or straps
- Attach transportation equipment only to positions intended for this purpose.
- Lifting and securing equipment must conform to the provisions contained in accident prevention regulations
- Consider the weight of the furnace when choosing lifting and securing equipment. (see Specifications)
- Stainless steel parts (including mounting elements) must always be kept separate from unalloyed steel parts
- Do not remove corrosion protection until immediately prior to assembly



#### Risks during Normal Operation!

Suspended loads are dangerous. Working beneath a suspended load is prohibited. There is a risk of fatal injury.



#### Note

Safety and accident prevention guidelines applicable for forklift trucks must be followed.

#### Transportation with a Pallet Truck

Observe the maximum permitted capacity of the pallet truck.

1. Our furnaces are delivered ex works on wooden frames to facilitate unloading. Transport the furnace in its original packaging and with suitable equipment to prevent any damage. Remove the packaging only when the furnace is in its final location. When transporting the furnace, make sure it is secured against sliding, toppling over, and damage. The furnace should be transported and installed by at least two persons. **Do not store the furnace in damp rooms or outdoors.**
2. Push the pallet truck underneath the transportation frame. Make sure that the pallet truck is **completely** beneath the frame. Pay attention to neighboring goods.

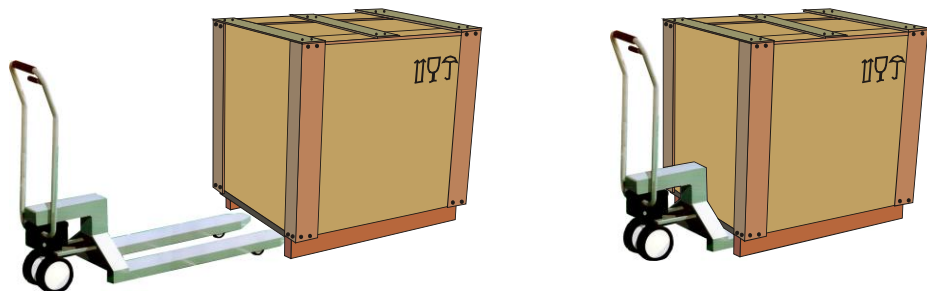





Fig. 10: Pallet truck is pushed **completely** beneath the transportation frame

3. Lift the furnace carefully and pay attention to its center of gravity. When the furnace is being lifted, make sure that the ends of the forks or the load do not catch on neighboring goods.
4. Make sure that the furnace is balanced safely; if not, attach securing equipment. Push the furnace carefully, slowly and with the pallet truck at its lowest position. Do not transport the furnace on inclines.
5. Carefully lower the furnace at its final position. Pay attention to neighboring goods. Try not to set it down too abruptly.

**Symbols:**

The symbols for handling packaging are defined in ISO R/780 (International Organization for Standardization) and in DIN 55402 (German Institute for Standardization).

Description	Symbol	Explanation
Fragile		This symbol is to be attached to fragile goods. Goods marked like this are to be handled carefully and must not be thrown or tied up.
This side up		The freight must be transported, transhipped, and stored in such a way that the arrows point upward. The freight must not be rolled, folded, or stored on edge. However, the package does not have to be packed on top of other freight.
Keep dry		Products with this symbol must be protected against high air moisture, hence, they must be stored under cover. If particularly heavy or bulky packages cannot be stored in halls or sheds, they must be covered carefully with a tarpaulin or similar.
Sling here		The symbol shows only where the sling should be attached, not the method of slinging. If the symbols are at an equal distance from the middle or center of gravity of the package, the package hangs straight if the slings are the same length. If this is not the case, the sling on one side has to be shortened.

**5.2 Unpacking**



**Note**  
The furnace packaging prevents damage during transportation. Make sure that you remove all packaging material (also inside the Furnace Chamber). Keep the packaging and transportation securing equipment in case it is needed for future transportation or storage.  
At least two people are needed to carry/transport the furnace, more for larger furnaces.



Wear protective gloves

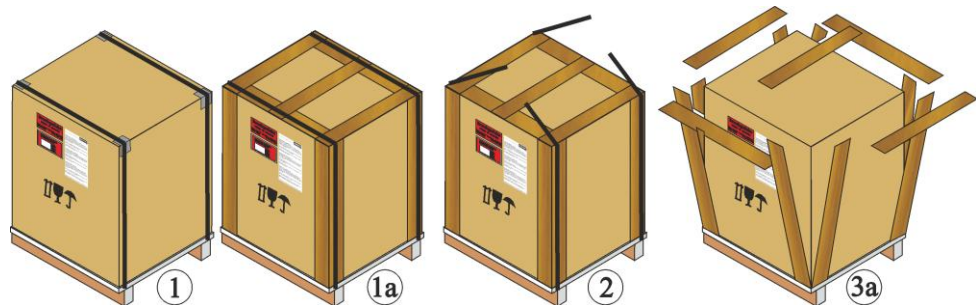

1. Check the transportation packaging for possible damage.
2. Remove tensioning straps from the transportation packaging.
3. Slacken screws and remove wooden casing from the covering box (if available 3a).

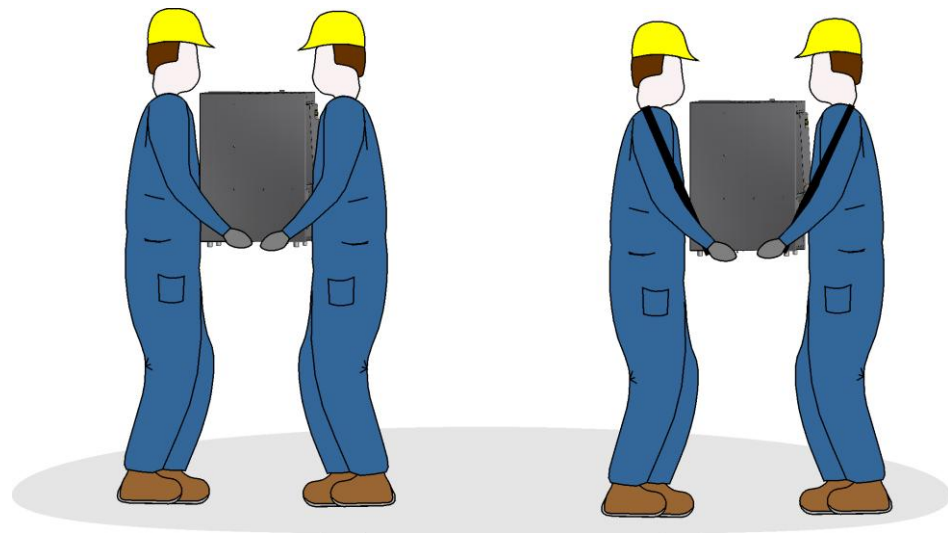
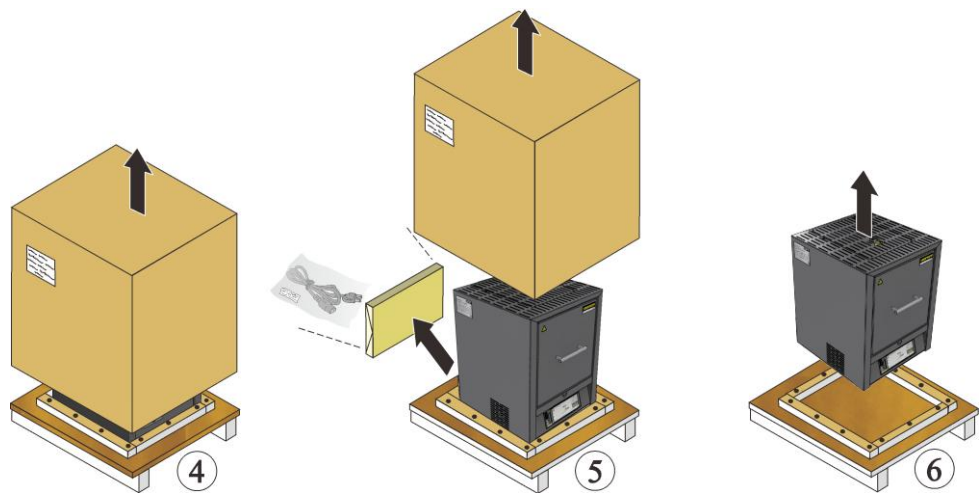

4. To carry, grip furnace from below at the sides and make sure you have a firm grip.
5. For furnaces weighing more than 25 kg, transport work must be carried out by at least 2 people. If transport straps are used, they must be attached crosswise only. Ensure that they are secure.



**Note**

In Germany, the general accident protection guidelines of VBG or BGZ must be observed. The national accident prevention regulations of the country of operation apply.



**Note**

Save the packaging for possible shipping or for storing the furnace.

### 5.3 Transport Securing Device/Packaging

The furnace has been equipped with transport protection to protect it against damage during transportation, which must be removed before you use the furnace.

**First** remove the adhesive strips and then pull out the transportation protection. Pull the furnace door slightly towards you; this makes it easier to remove the transportation protection from the furnace (see figure: Removing the transportation protection).

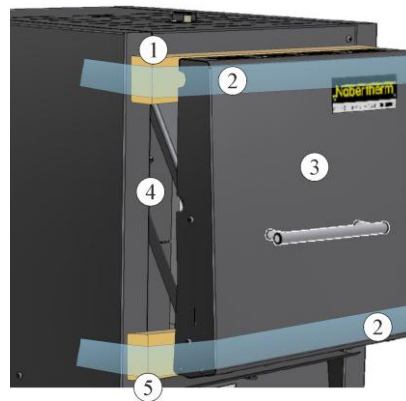

- 1 Remove the transportation protection upwards
- 2 Remove the adhesive strips
- 3 Lift door
- 4 Furnace housing
- 5 Remove the transportation protection downwards.

Fig. 11: Removing the transportation protection (similar to picture)

**Note**

Keep the transportation protection in case it is needed for future transportation or storage. To prevent damage to the furnace door insulation during any future transportation, the furnace must be protected as shown in the picture above.

Observe the instruction for installing the insulation block and the exhaust air tube, refer to “Installing the Exhaust Air Tube”.

## 5.4 Constructional and Connection Requirements

### 5.4.1 Installation (Furnace Location)

When setting up the furnace, these safety instructions must be followed:

- The furnace must be installed in a dry room in accordance with the safety instructions.
- The table/supporting surface must be flat to enable the furnace to be installed straight. Place the furnace on a **non-flammable** surface (fire safety class A DIN 4102 – Example: concrete, tiles, glass, aluminum or steel) so that any hot material falling from the furnace cannot ignite the surface.
- The carrying capacity of the table must be designed to bear the weight of the furnace incl. accessories.
- The floor covering must be made of non-flammable material so that hot material falling out of the furnace will not cause the floor covering to ignite.

**Installation Location**

- The operator is responsible for adequate ventilation by installing the appropriate systems to supply fresh air and to vent exhaust air. If a batch emits gases or vapors, adequate ventilation of the installation site must be provided as well as a suitable exhaust air venting system. A suitable vent for combustion exhaust must be supplied by the customer
- Make sure that the heat radiated by the furnace is vented (consult a ventilation expert, if necessary)

- Although the furnace is well-insulated, the exterior surfaces of the furnace radiate heat. If necessary, this heat must be dissipated (**a ventilation technician may need to be consulted**). In addition, a minimum clearance (**S**) of 0.5 m on all sides and 1 m above the furnace must be maintained to flammable materials. In individual cases, more space must be chosen in order to match the local conditions. For **nonflammable materials**, the minimum **side** clearance can be reduced to 0.2 m.
- The furnace must be protected against weather and caustic atmospheres. Nabertherm accepts no liability or warranty claim for any corrosion damage as a result of installation in damp surroundings or for similar reasons.

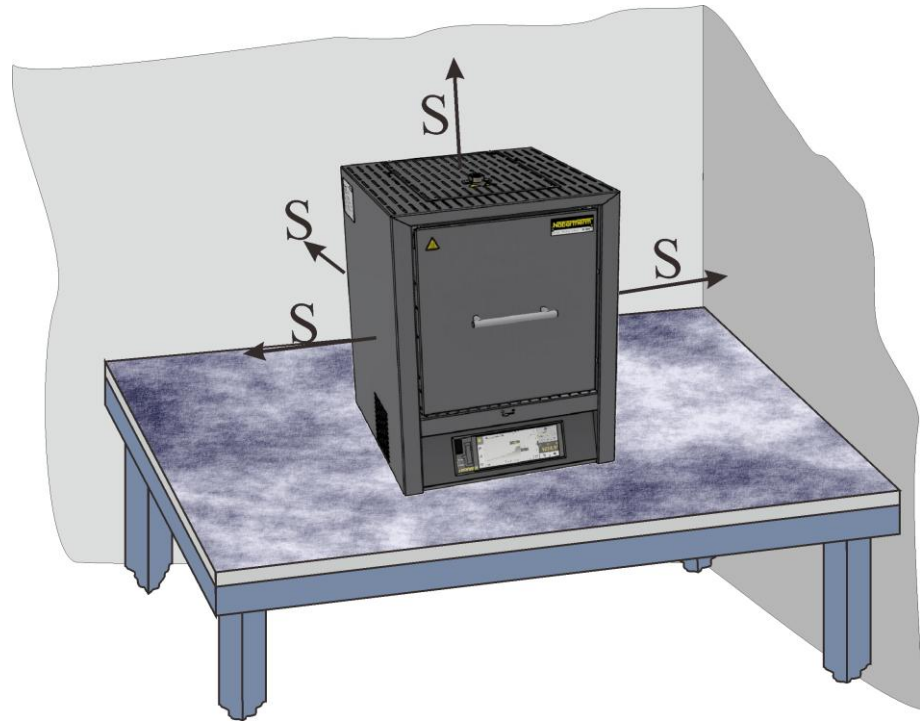





Fig. 12: Minimum safety gap to flammable materials (tabletop model) (similar to picture)

	 <b>DANGER</b>
	<ul style="list-style-type: none"> <li>• <b>Risk of fire, danger to health</b></li> <li>• <b>Risk of fatal injury</b></li> <li>• Adequate ventilation must be ensured at the installation location to remove exhaust heat and exhaust gases</li> </ul>



**Note**

Before starting the furnace for the first time, allow it to acclimatize at its installation location for 24 hours.

	<p style="text-align: center;"><b>! DANGER</b></p> <ul style="list-style-type: none"> <li>• <b>Danger associated with the use of an automatic extinguishing system</b></li> <li>• <b>Danger to life from electrocution through wetness, suffocation caused by extinguishing gas, etc.</b></li> <li>• If automatic extinguishing systems are in place to fight fires and protect the building, e.g. sprinkler systems, care must be taken during their planning and installation that no additional hazards are created, for example by extinguishing a pilot light, mixing hardening oil and extinguishing water, shutdown of electrical equipment, etc.</li> </ul>
---	---

## 5.5 Assembly, Installation, and Connection

### 5.5.1 Installing the Exhaust Air Tube

To avoid damaging the furnace insulation and also the insulation block and exhaust air tube, both are delivered in a separate package. Before initial start-up, the insulation block and exhaust air tube must be inserted and secured in the intended opening. The furnace must not be started without the insulation block and exhaust air tube in place.

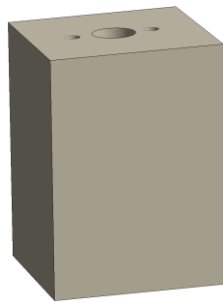

Insulation block



Exhaust air tube

Fig. 13: Included in scope of delivery (similar to picture)

#### Removing the protective plate of the exhaust air tube

Use a suitable tool to undo the screws on the protective plate of the exhaust air tube. Place the screws and the protective plate in a safe place so that they can be reused (disconnect the plug).

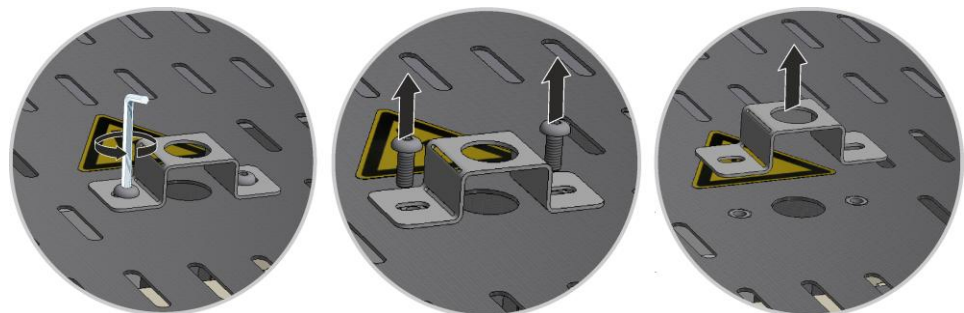

Fig. 14: Removing the protective plate from the exhaust air tube (similar to picture)

### Removing the top cover from the furnace housing

Unscrew all the screws of the panel with a suitable tool and keep them in a safe place for future use.

The number and position of the screws may differ from one furnace model to the next. The furnace may look different than the picture depending on the furnace model and features.

The cover must be lowered onto a soft material (such as foam rubber).

If present, pay attention to the protective ground cable of the back wall to the clamp. If necessary, disconnect the cable from the clamp.



Fig. 15: Dismantling the cover (similar to picture)

### Installing the insulation block

Carefully remove the packaging from the insulation block. Place the insulation block on the center of the hole in the top of the furnace. Make sure that the two top holes (A) are parallel to the top of the furnace housing.

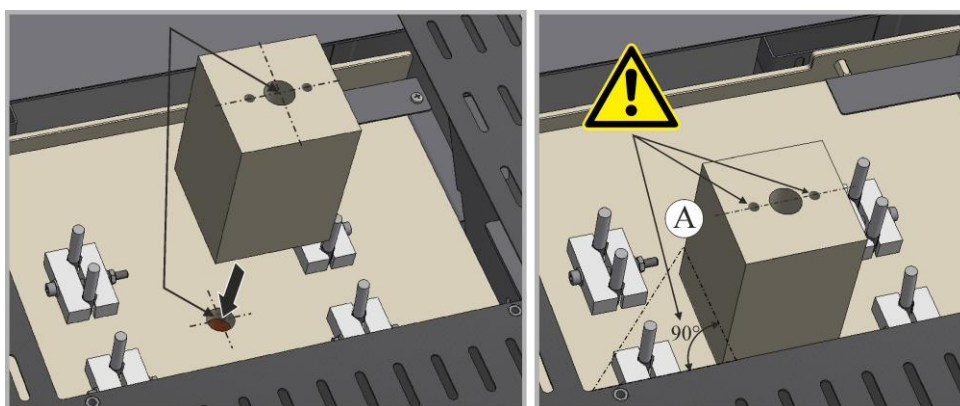

Fig. 16: Installing the insulation block (similar to picture)

### Positioning and installing the cover

Place the cover on the furnace housing and fix it in place with the screws that were previously removed.



Fig. 17: Installing the cover (similar to picture)

### Installing the exhaust air tube

Carefully slide the exhaust air tube into the opening. The top of the exhaust air tube must sit on the furnace cover. Reinstall the protective metal sheet of the exhaust air tube with the screws that were previously removed.

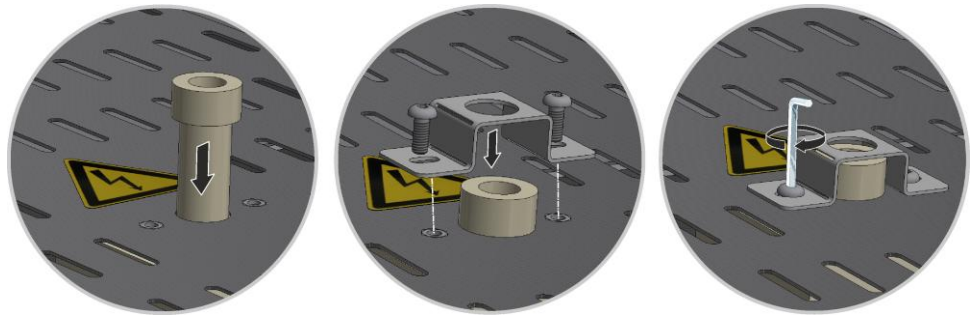

Fig. 18: Installing the exhaust air tube (similar to picture)



**Caution**

Make sure that no cables poke out or are caught. Beware of sharp edges.



**Note**

Make sure that all screwed and plugged connections are in working order.

### 5.5.2 Venting Exhaust Fumes

We recommend connecting an exhaust air pipe to the furnace to remove the exhaust gases. For this purpose you can use a commercially available, metal exhaust gas pipe with NW80 to NW120. It must be installed continuously rising and fastened to the wall or ceiling. Center the pipe over the furnace vent.

The exhaust gas pipe must not be installed with a tight fit to the furnace vent pipe since this would prevent any bypass effect. This is necessary so that not too much fresh air is sucked in by the furnace.

We recommend feeding the exhaust air through a flue.

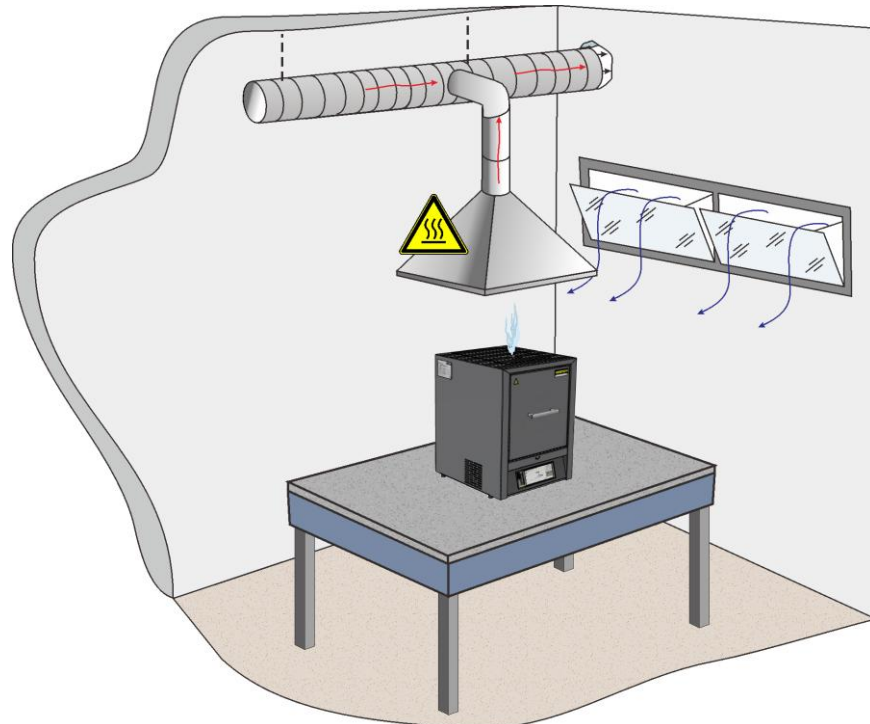

Fig. 19: Example: Installing an exhaust extraction system (similar to picture)



**Note**

Exhaust gases can be vented only if the room is ventilated with a corresponding fresh air inlet.



**Note**

Roof work and/or masonry by the customer is required for the exhaust gas extraction. The size and design of the exhaust gas system must be defined by a ventilation engineer. The accident prevention regulations applicable in the country where the furnace is installed must be observed.

## 5.6 Air Inflow Lever

The volume of air fed to the furnace can be adjusted with the fresh air lever. The fresh air lever is located at the side of the door at the bottom. The position is explained by the symbols beside and on the lever.

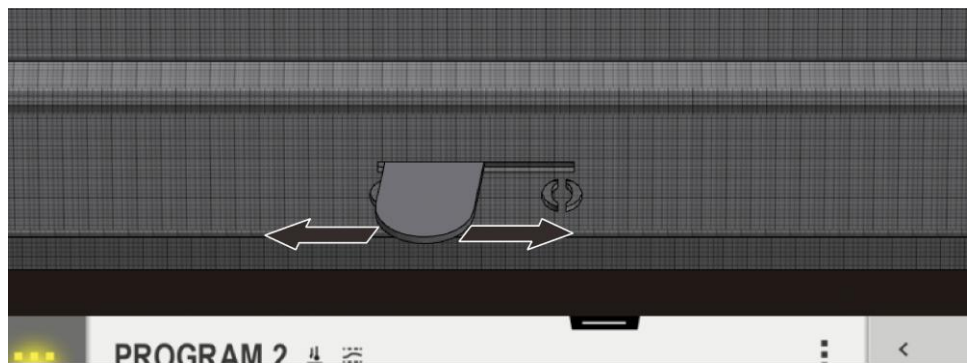

Fig. 20: Fresh air lever (figure similar)

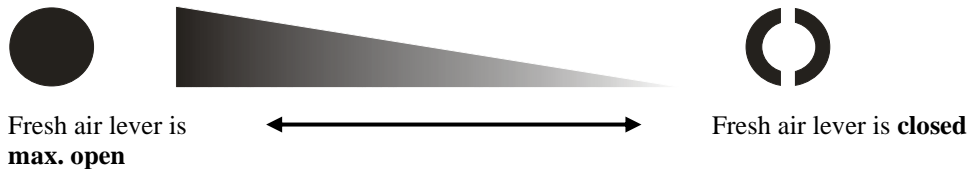

Fig. 21: Regulating the feed of fresh air (symbols)



**Note**

If the fresh air lever is open, under certain circumstances this may affect temperature uniformity in the furnace chamber.



**Note**

When the fresh air lever is opened fresh air is guided in the furnace chamber for drying or forced cooling. Please make sure that the fresh air lever is closed after drying in order to achieve a good temperature uniformity during sintering.

The application notes of the zirconia manufacturer should be generally taken into consideration in order to avoid damages at the charge e.g. due to fast cooling times.

## 5.7 Connecting the Furnace to the Power Supply

The customer must ensure that the floor has adequate load-bearing capacity and that the necessary energy (electricity) is provided.

- The furnace must be installed according to its intended use. The power connection must correspond to the values on the furnace type plate.
- The power socket must be close to the furnace and be easily accessible. The safety requirements are not met if the furnace is not connected to a socket with a protective ground contact.
- Do not use extension cables or power strips.
- The power cable must not be damaged. Do not place any objects on the power cable. Lay the cable in such a way that no one can stand on it or trip over it.
- Power cables may be replaced only with similar, approved cables.
- Ensure that the connection cable of the furnace is protected.

### Note

Before connecting the power, make sure that the power switch is set to "Off" or "0".

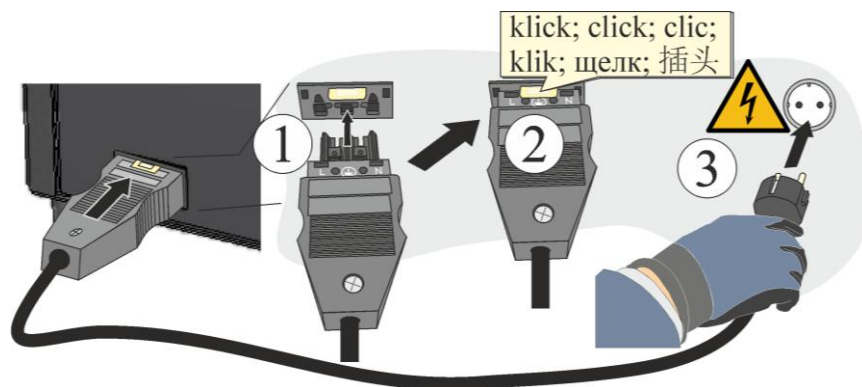

Fig. 22: Depending on model – supplied power cable included in scope of delivery (illustration similar)

1. Plug the supplied connection cable with snap-in coupling into the rear wall of the furnace.
2. Then connect the power cable to the power supply. Use only a grounded socket.

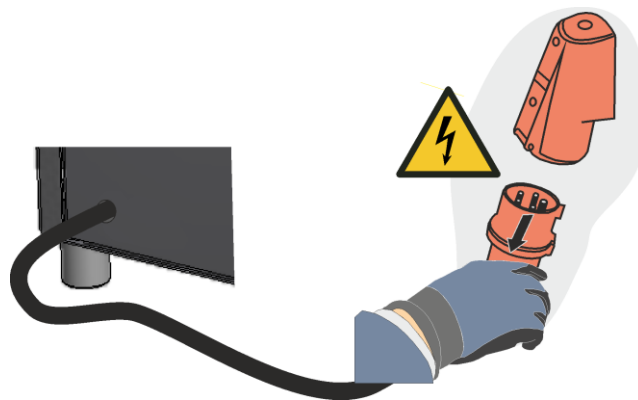

Fig. 23: Depending on model (CEE/NEMA plug) (similar to picture)

1. Connect the power cable to the power supply. Use only a grounded socket.  
Testing of ground resistance (compliant with VDE 0100); also refer to the accident prevention regulations.

Electrical systems and operating equipment compliant with DGUV V3.

**Power Connection without Plug-In Power Line:**

The power line must have a fixed connection in the switchgear cabinet, either at the available terminals or, in models without a separate switchgear, to the main switch. When carrying out this work pay attention to the specs on the type plate: network voltage and type, and maximum power consumption.

The fuse protection and the cross-section of the required power connection depend on the surrounding conditions, the length of the line and how it is installed. For this reason, the type of protection and how it should be installed must be decided by a qualified electrician.

- The power cable must not be damaged. Do not place any objects on the power cable. Lay the cable so that nobody can step on it or trip over it.
- The power line may only be replaced by an approved, equivalent line
- Ensure that the connection line of the furnace is protected

This protection must be compliant with locally applicable standards and regulations.

Ensure that the protective conductor terminal is correct.

When several phases are involved, they must be connected with a clockwise rotating field in the sequence L1, L2, L3.

Before you switch on the furnace for the first time make sure that **a clockwise rotating field is in place**. This is a prerequisite for the smooth functioning of the furnace.



**Note**

The national regulations of the respective country of operation apply.



**Warning – Danger of Electric Shock!**

Work on the electrical equipment may be done only by qualified, authorized electricians.

	<b>CAUTION</b>	
	<ul style="list-style-type: none"> <li>• <b>Danger from incorrect voltage</b></li> <li>• <b>Damage to the device</b></li> <li>• Check voltage before connecting and starting the furnace</li> <li>• Compare the voltage with the details on the type plate</li> </ul>	

	<b>DANGER</b>
	<ul style="list-style-type: none"> <li>• <b>Risk of fire, danger to health</b></li> <li>• <b>Risk of fatal injury</b></li> <li>• Adequate ventilation must be ensured at the installation location to remove exhaust heat and exhaust gases</li> </ul>

## 5.8 Insertion of the Base Plate (Accessories)

Carefully place the insert plate(s)\* (number of insert plates depends on the furnace model), distributed across the floor of the furnace, starting from the middle. When placing the insert plate(s) make sure that neither the door collar nor the heating elements are damaged. Absolutely avoid touching the heating elements when inserting the heating plate(s). Contacting the heating elements can result in their immediate destruction.

The furnace floor is made of high-quality refractory material but this material is highly sensitive to impact or pressure.

Some models are supplied with one insert plate as a standard in order to prevent the soft furnace floor from being damaged. Nabertherm accepts no liability for damage (e.g. depressions) in the furnace floor resulting from not using these insert plates\*. Damaged insert plate(s) must be immediately replaced with new ones (see the section "Spare Parts/Wearing Parts").

The charge must be positioned in the furnace chamber, on the floor, as centered as possible. This ensures uniform heating.

After charging, the furnace door must be closed carefully.

\*in scope of delivery depending on the design/furnace model

### Note

It must be ensured that the load on the furnace base does not exceed 2 kg/dm<sup>2</sup>.

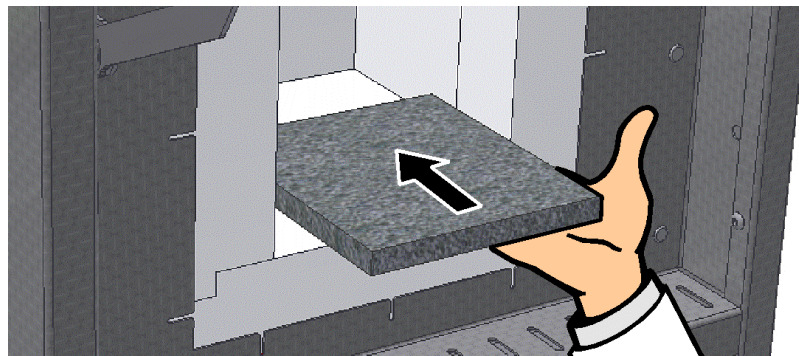

Fig. 24: Inserting the ceramic insert plate (in scope of delivery depends on design/furnace model) (similar to picture)

## 5.9 Initial Start-Up

The furnace may be put into operation only by qualified persons and in compliance with the safety instructions.

Read the section on "Safety". When the furnace is put into operation, the following safety information must also be observed to prevent serious injury, damage to the furnace, and damage to other property.

Make sure that the instructions and information in the controller instructions are observed and followed.

The furnace may be used only for its intended purpose.

Ensure that only authorized persons remain in the working area of the furnace and that no other persons are put at risk when the furnace is put into operation.

Before starting the furnace for the first time, make sure that all tools, foreign parts, and transportation securing equipment have been removed.

Activate all safety equipment (power switch, emergency stop button if applicable) before putting the furnace into operation.

Incorrectly wired connections may destroy electric/electronic components.

Observe the special protective measures (e.g. grounding, ...) for components that are at risk.

Faulty connections can cause the furnace to start unexpectedly.

Before you switch on the furnace, make sure that you know what to do in case of faults or emergencies.

Before starting the furnace for the first time, check the electrical connections and control displays.

Before placing materials in the furnace, check whether they could harm or destroy the insulation or the heating elements. Materials that could damage the insulation include: alkalis, alkaline earths, metal vapors, metal oxides, chlorine compounds, phosphorous compounds, and halogens.

### 5.9.1 Molybdenum Disilicide (MoSi<sub>2</sub>) Heating Elements

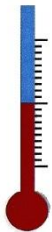

To generate a protective oxidated layer on the heating elements the furnace must be heated to below the maximum temperature 100 °C (212 °F) for approx. 5 hours (Example: The furnace is designed for a maximum temperature of approx. 1750 °C (3182 °F), hence a temperature of approx. 1650 °C (3002 °F) should be entered on the controller. But this temperature must be reached over the full period of five hours).

The entered temperature (example: 1650 °C (3002 °F)) should be held for approx. 5 hours. This process should be executed during the start-up, after replacing the heating elements or to regenerate the oxide layer.

When the furnace is heated up for the first time, annoying odors may result, these are due to the escape of binding agents from the insulation material. We recommend that the furnace location be well ventilated during the first warm-up phase. Let the furnace cool down naturally to room temperature.

#### Chemical Resistance:



Furnaces heated with molybdenum disilicide elements (MoSi<sub>2</sub>) are available for max. furnace chamber temperatures of 1600, 1750 and 1800 °C. The max. furnace chamber temperature refers to operation in air. At temperatures of over 800 °C, a layer of silicon oxide occurs on the surface of the heating element, protecting it against further oxidation. Such a protective layer is not formed at low temperatures. If the surface of the element is not protected, molybdenum and silicon oxidation can take place at temperatures of around 550 °C. This leads to the occurrence of a yellowish powder consisting primarily of molybdenum oxide (MoO<sub>3</sub>). This chemical reaction has no disadvantageous effects on the performance of the heating element.

If **non-combustible protective gases** are used, the max. permissible furnace chamber temperature is **reduced** to 100 °C (212 °F). When using forming gases (95/05 N<sub>2</sub>/H<sub>2</sub> or 98/02 Ar/H<sub>2</sub>) oxidation burns at regular intervals are necessary and signs of increased wear can appear on the heating elements and the insulation.

#### Resistance to Metals and Oxides:

The heating elements should never come into contact with solid materials.

#### Metals:

In an oxidizing atmosphere, the majority of metals form scale on the surface (oxide formation occurs due to a thermal influence in an oxidizing atmosphere). This metal oxide may react with the silicon oxide of the heating element and shorten its service life. If the

furnace is used to melt metals, it must be ensured that the furnace chamber is protected against metal splashes, soiling and vapors which occur during the melting process (particularly due to fluxing agents). Metal oxides also strongly corrode the insulation of the furnace.

**Alkalines:**

Alkaline compounds may corrode the heating elements. Alkaline compounds also lead to rapid destruction of the insulation.

**Ceramic:**

Ceramic may destroy the heating element on direct contact. Salts and oxides from the ceramic may additionally react with the silicon oxide of the heating element and shorten its service life.

**Glass:**

If glass is melted, the furnace atmosphere contains contaminants, the composition of which depends on the relevant glass product. These components usually act as a fluxing agent on the silicon oxide layer. As a result, its viscosity is reduced and the silicon oxide flows slowly down the heating element. However, new silicon oxide is immediately formed again, with the result that the service life is not noticeably shortened. The insulation may also be severely corroded depending on the type of glass.

**Note**

Before starting the furnace for the first time, allow it to acclimatize at its installation location for 24 hours.

**Note**

Continuous operation at maximum temperature can lead to increased wear of heating elements, insulation materials and metallic components. We recommend working at approx. **50 °C below maximum temperature**.

**Notice**

Observe the safety instructions for furnace furniture (sinter bowls, saggars, etc.) in the “Stackable Saggars” section.

**Warning - Danger of Electric Shock!**

For the protection of the operator and the furnace, the heating program must be stopped before the furnace is loaded. Ignoring this warning can result in electric shock.

**Cracks in the Insulation**

The insulation of the furnace consists of a very high-quality refractory material. Heat expansion may cause cracks in the insulation even after a few heating cycles. However, these have no effect on the functioning or quality of the furnace. This is no reason for a complaint.

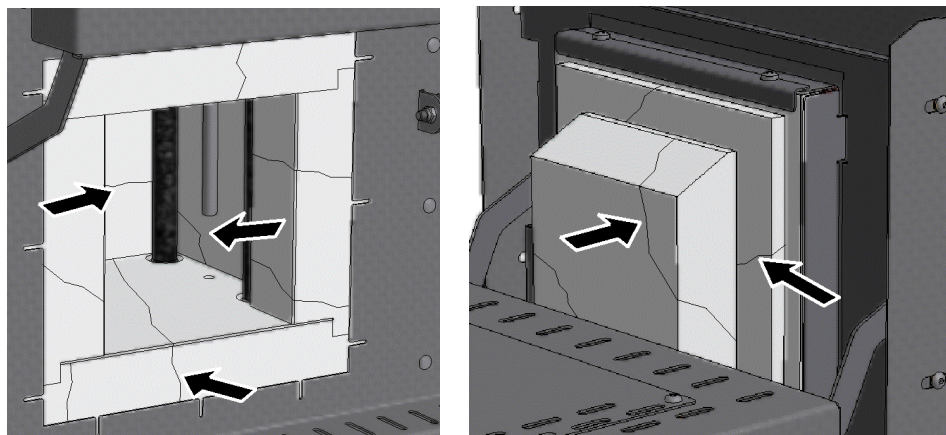
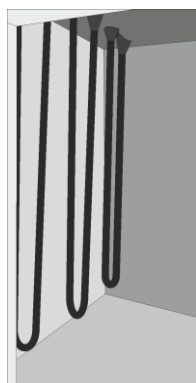

Fig. 25: Example: Cracks in the insulation after a few warm-up cycles (figure similar).

At the time of the first start-up and repeated heating up of the furnace one or more heating elements may become deformed.

It is due to the nature of molybdenum-disilicide in the heating elements that they tend to deform. But this appearance, however, has no influence on the function or quality of the furnace and, hence, is no reason for a complaint.



Before the first start-up



After the first start-up and/or after a few heating up phases.

Fig. 26: Example: Deformation of the heating elements made of molybdenum-disilicide

## 5.10 Loading/Charging

Swivel the furnace door carefully away upwards.

Only materials with known characteristics and melting temperatures may be used. Observe the material safety data sheets if necessary.

When loading the furnace, ensure that the door collar and the heating elements are not damaged. Under all circumstances, avoid coming into contact with the heating elements when loading the furnace; this may lead to the immediate destruction of the heating elements.

If possible, the load must be positioned centrally in the working chamber on the ceramic insert plate. This guarantees even heating.

If a large quantity of material is placed into the furnace chamber, the heating time may increase significantly.

If a crucible is used, make sure that the material to be melted is inserted carefully into the crucible. Crucibles are sensitive to shocks and impact. Metals expand more quickly and strongly than the crucible when heated. Be sure that the recommendations of the crucible manufacturer for maintenance and handling are carefully observed.

After loading, the furnace door must be closed carefully. The furnace door should be closed gently in order not to damage the insulation. Make sure that the door is closed correctly.

If possible, the furnace must **not** be opened when hot. If it has to be opened at a high temperature, this should take place as briefly as possible. Attention must be paid to adequate protective clothing and room ventilation, see chapter "Safety".

The stainless steel sheet may become discolored (particularly on opening when hot), but this does not impair the function of the furnace.

**Additional care measures**

Ensure that objects like teapots, bottles, and similar items are kept away from the furnace.



**Warning - Danger of Electric Shock!**

For the protection of the operator and the furnace, the heating program must be stopped before the furnace is loaded. Ignoring this warning can result in electric shock.

**5.10.1 Stackable Saggar (Accessories)**

Nabertherm offers special-purpose saggars for charging the furnace.

Placing the zirconia product in charge saggars provides for optimum utilization of the furnace chamber. Up to three saggars can be stacked in the furnace. The integrated air slots ensure a better air circulation of the charge. The upper saggar can be closed with a separate ceramic lid.

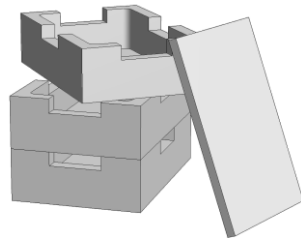

Safe charging on up to three levels

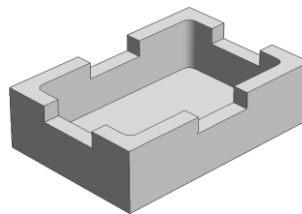

Charge Saggar

Article No.: 699000279

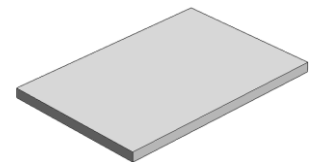

Lid for Charge Saggar

Article No.: 699000985

Fig. 27: Saggars with top lid



**Note**

The accessories described above are designed for cold charging and discharging. Removing the accessories in hot condition is not possible.

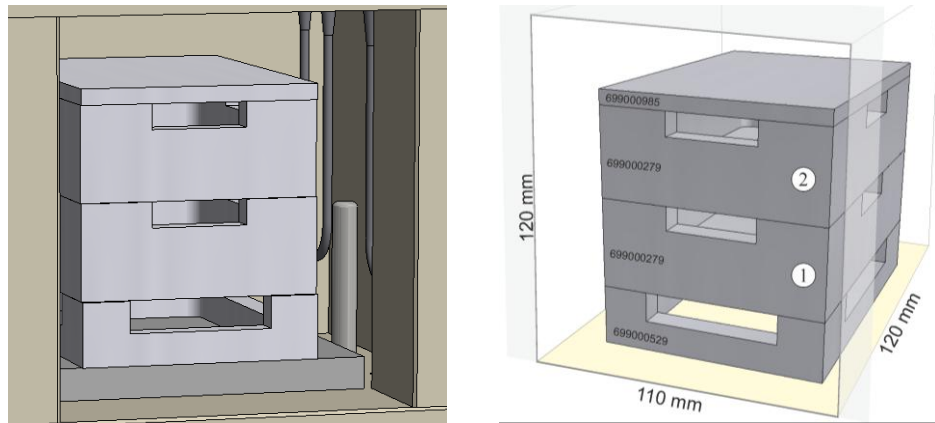

Fig. 28: Safe charging on up to 2 levels (similar to picture)

The lowest charge saggarr must be positioned in the middle on the floor board (ceramic insert board) to ensure uniforming heating of the charge.

When charging make sure that neither the door collar nor the heating elements are damaged. Make absolutely no contact with the heating elements. Any contact with the heating elements can result in their destruction.

After charging, the furnace door must be closed carefully. The insulation of the furnace door must not push the charge saggarr into the furnace chamber.



**Warning - Danger of Electric Shock!**

For the protection of the operator and the furnace, the heating program must be stopped before the furnace is loaded. Ignoring this warning can result in electric shock.

## 6 Operation

### 6.1 Controller

#### B510/C550/P580

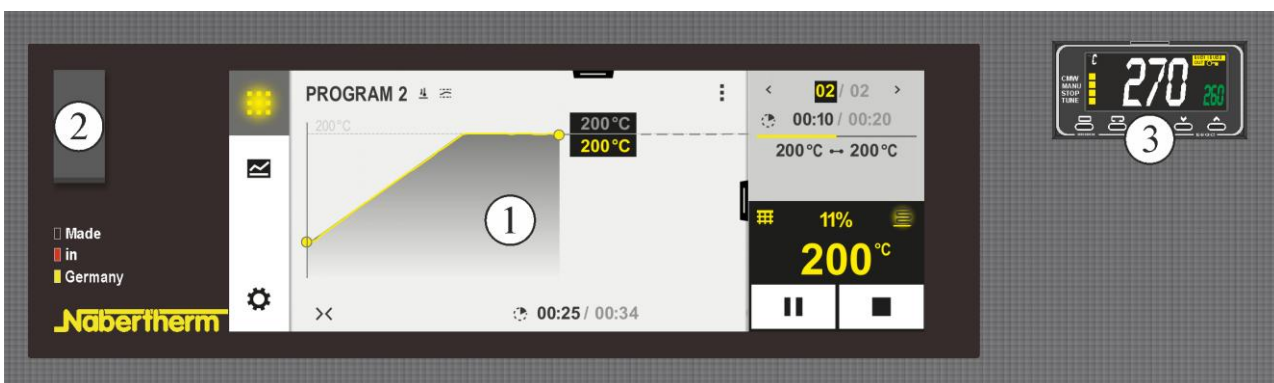

Fig. 29: Control field B510/C550/P580 (similar to picture)

No.	Description
1	Display
2	USB interface for a USB stick
3	Over-temperature limiter with manual reset (optional)



**Note**

See the separate operating instructions for a description of how to enter temperatures and times and to “start” the furnace.

## 6.2 Operation, Display and Switch Elements (depending on design)

### 6.2.1 Turning on the Controller/Furnace

Turning on the controller		
Procedure	Display	Comments
Turn on the power switch		Set power switch to “I”. (Power switch type varies according to design/furnace model)
The furnace status is displayed. After a few seconds, the temperature is displayed.		When the temperature is shown on the controller, the controller is ready for operation.

### 6.2.2 Turning off the Controller/Furnace

Turn off the controller		
Steps	Display	Comments
Turn off the power switch		Turn off the power switch by setting it to "O" (power switch type differs depending on features/furnace model)

All the necessary settings for perfect functions have already been made at the factory.



**Note**

See the separate operating instructions for a description of how to enter temperatures and times and to “start” the furnace.



**Note**

Continuous operation at maximum temperature can lead to increased wear of heating elements, insulation materials and metallic components. We recommend working at approx. **50 °C below maximum temperature.**

## 7 Servicing, Cleaning, and Maintenance



### Warning – General hazards!

Cleaning, lubrication, and maintenance tasks may be performed only by authorized professionals observing the maintenance instructions and accident protection regulations. We recommend that maintenance and repair work be carried out by the service team of Nabertherm GmbH. Disregard of this may cause injuries, death, or considerable damage to property.



### Warning – Danger from electrical voltage

Work on the electrical equipment may be done only by qualified, authorized electricians.



During maintenance work, the furnace and/or switchgear must be disconnected from the power supply and safeguards must be taken to ensure that they cannot be switched on again inadvertently. For safety reasons, pull out the power plug.

Operators may only rectify malfunctions that are obviously due to operating errors.

Wait until the furnace and the connected parts have cooled to room temperature.

Regularly inspect the furnace visually for damage. Also, clean the inside of the furnace as required (e.g. with a vacuum cleaner). **Caution:** Do not touch the heating elements as they may break.

While work is being carried out on the furnace, the furnace and the room in which it is installed should be ventilated with fresh air.

Protective equipment that was removed during maintenance work must be replaced and checked once the work is finished.

Warning about suspended loads at the workplace (e.g. cranes). Working beneath a suspended load (e.g. lifted furnace or switchgear) is prohibited.

The functions of safety switches and end switches must be checked at regular intervals (according to DGUV Regulation 3 or corresponding national regulations of the country in which the system is used).

To ensure perfect temperature control of the furnace, the thermocouple must be checked for damage before each process.

Tighten the screws of the element holders (see “Replacing a Heating Element”) if necessary. Before carrying out this work, the furnace and/or the switchgear must be disconnected from the power supply (disconnect the power plug). Regulations (DGUV Regulation 3 or corresponding national regulations of the respective country of use) must be observed.

The switchgear contains one or more contactors. The contacts of these contactors are wearing parts and must therefore be maintained regularly and replaced as required (DGUV Regulation 3) or according to the corresponding national regulations of the country where the switchgear is installed.

The switchgear cabinet (if present) has ventilation grilles with integrated filter mats. These must be cleaned regularly and be replaced when necessary to ensure adequate ventilation of the switchgear. During melting operations, the control cabinet door must always be firmly closed.

## 7.1 Furnace Insulation



**During the work on the insulation or the replacement of components in the furnace chamber, the following points must be observed:**

When repairs are made or demolition work is performed, silicon dust may be released. Depending heat-treated materials contained in the furnace, further contaminants may be contained in the insulation. To exclude possible health risks, dust concentrations must be kept to a minimum during any work performed at or near the insulation. In many countries there are specific occupational safety limits. You can acquire more relevant information by investigating the relevant legal specifications in your country.

Dust concentrations should be kept as low as possible. Dust must be removed using a suction device or a vacuum cleaner with a high-performance filter (HEPA – category H). Strong air currents such as drafts, for example, must be prevented. Pressurized air or brush must not be used for cleaning. Piles of dust must be sprinkled.

During work on the insulation a respirator mask with an FFP2 filter or an FFP3 filter must be used. The work clothing must be loose and cover the body completely. Gloves and goggles must be worn. Soiled clothing should be cleaned before it is removed with a vacuum cleaner equipped with a HEPA filter.

Contact with skin and eyes should be avoided. The impact of fibers on skin or eyes can lead to mechanical irritation which, in turn, causes reddening and itchiness. After completing the work, or after direct contact, the skin must be washed with soap and water. If there is contact with the eyes, they must be washed out carefully for several minutes. If necessary, an eye doctor should be consulted.

Smoking, eating and drinking at the workplace is prohibited.

When working on insulation, the Technical Regulations for Hazardous Materials must be applied in Germany. <http://www.baua.de> (German).

Additional information regarding how to handle fibrous materials can be found at <http://www.ecfia.eu> (English).

When the materials are discarded, national and regional guidelines must be observed. The possible presence of hazardous contaminants generated by the furnace process must be taken into account.

## 7.2 Shutting the System Down for Maintenance

**Wait until the furnace and the connected parts have cooled to room temperature.**

- The furnace must be completely empty
- Inform operating personnel and nominate supervisors
- Switch off the main switch and/or disconnect the power plug
- Lock the main switch (if available) and secure it with a padlock to prevent it from being switched on
- Attach a warning sign to the main switch
- Secure a large zone around the area where maintenance work is being carried out
- Make sure that the system is de-energized
- Ground and short-circuit the working area
- Cover neighboring live parts



**Warning - Dangers During Normal Operation!**

Do not touch any object without first having checked its temperature.



**Warning – Danger from electric voltage**

Work on the electrical equipment may be done only by qualified, authorized electricians. During work it must be ensured that the furnace and the switching equipment cannot be activated by mistake (pull out the power plug) and that all moving parts in the furnace are secured. DGUV V3 or corresponding national regulations of the respective country of use must be observed. Wait until the furnace and the connected parts have cooled to room temperature.

### 7.3 Regular Maintenance of the Furnace

Component/ item/ function and action	Comment	A	B	C
<b>Safety test in accordance with DGUV V3 or corresponding national regulations</b> According to regulation	According to regulation	-		X2
<b>EMERGENCY STOP (if present)</b> Press the button		-	D	X1
<b>Safety and limit switch (if present)</b> Function test		-	Y	X2
<b>Furnace chamber, extraction holes and extraction tubes</b> Clean and inspect for damage, vacuum carefully		-	M	X1
<b>Sealing surfaces: Door collar/furnace collar</b> Visual inspection		-	D	X1
<b>Seals (if present)</b> Clean/replace		2	W	X1
<b>Heating elements/process insert hood (if present)</b> Visual inspection		2	D	X1
<b>Element holder screws, refer to “Checking Heating Element Screws” (if present)</b> Check the element holder screws and tighten carefully if required	<sup>1</sup> first time <sup>2</sup> subsequently	-	W <sup>1</sup> Y <sup>2</sup>	X2
<b>Check for uniform power consumption of the heating system</b> Function test		-	Y	X2
<b>Thermocouple</b> Visual inspection (visible part of the heating element inside the furnace chamber)		1	D	X1
<b>Lift bottom setting (if present)</b> Check that the lift bottom closes completely		-	D	X1
<b>Settings on over-temperature limiter (if present)</b> With each change to the heat treatment program	With each change in the heat treatment program, check the cutout temperature (alarm value) on the over-temperature limiter	-		X1
<b>Measurement and control accuracy</b> Calibration		-	Y	X2

Component/ item/ function and action	Comment	A	B	C
<b>Switchgear fan</b> Function check	Each start-up	-	D	X1

**Key:** see “Maintenance Table Key”



**Warning – Danger of Electric Shock!**

Work on the electrical equipment may be done only by qualified, authorized electricians.



**Notice**

Maintenance work must be performed only by authorized persons, observing the maintenance instructions and the accident prevention regulations. We recommend that maintenance and repair work be carried out by the service team of Nabertherm GmbH.

### 7.3.1 Regular Maintenance Tasks – Documentation

Component/ item/ function and action	Comment	A	B	C
<b>Type plate</b> Legible condition		3	Y	X1
<b>Operating instructions</b> Ensure they are kept near the furnace		3	Y	X1
<b>Component instructions</b> Ensure they are kept near the furnace		3	Y	X1

**Key:** see “Maintenance Table Key”

### 7.3.2 Regular Maintenance Tasks – Heating Elements/Furnace Chamber

Component/ item/ function and action	Comment	A	B	C
<b>Heating elements</b> Visual inspection: Formation of an oxide coating, cracks		2	D	X1
<b>Heating elements</b> Replace		1	Y	X2
<b>Heating element holes</b> Clean	At the latest when replacing the heating elements	2	Y	X2
<b>Heating element connections</b> Wiring to the connections, corrosion tendency on twisted ends (traces of burning), torsion-free installation		3	Y	X2
<b>Heating element terminals</b> Check and, if necessary, tighten the screws of the terminals (observe torque)	See “Replacing a Heating Element”	2	Y	X2

Component/ item/ function and action	Comment	A	B	C
<b>Power to heating elements</b> Check load of heating groups		3	Y	X2

**Key:** see “Maintenance Table Key”

## 7.4 Maintenance Table Key

Symbols:	
<b>A = Spare Part Stocks</b>	<b>1</b> = Stocks urgently recommended <b>2</b> = Stocks recommended / <b>3</b> = As required, not relevant
<b>B = Maintenance Interval</b> <b>Notice:</b> If ambient conditions are severe, the maintenance intervals must be shorter.	<b>D</b> = Daily, each time before the furnace is started <b>W</b> = Weekly <b>M</b> = Monthly / <b>Q</b> = Quarterly <b>Y</b> = Yearly /
<b>C = Performed by</b>	<b>X1</b> = Operating personnel <b>X2</b> = Specialist personnel

## 7.5 Checking the Heating Element Screws



### Warning – Danger from electric voltage

Work on the electrical equipment may be done only by qualified, authorized electricians. During work it must be ensured that the furnace and the switching equipment cannot be activated by mistake (pull out the power plug) and that all moving parts in the furnace are secured. DGUV V3 or corresponding national regulations of the respective country of use must be observed. Wait until the furnace and the connected parts have cooled to room temperature.



### Caution – Damage to components!

Heating elements are extremely fragile. Avoid all stress or twisting of the heating elements. If this is not observed, the sensitive heating elements will be destroyed.

### Removing the protective plate of the exhaust air tube

Use a suitable tool to undo the screws on the protective plate of the exhaust air tube. Place the screws and the protective plate in a safe place so that they can be reused (disconnect the plug).

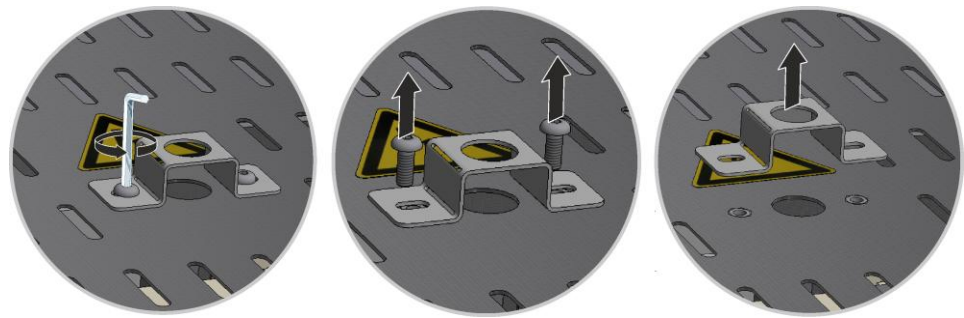

Fig. 30: Removing the protective plate from the exhaust air tube (similar to picture)

### Removing the top cover from the furnace housing

Unscrew all the screws of the panel with a suitable tool and keep them in a safe place for future use.

The number and position of the screws may differ from one furnace model to the next. The furnace may look different than the picture depending on the furnace model and features.

The cover must be lowered onto a soft material (such as foam rubber).

If present, pay attention to the protective ground cable of the back wall to the clamp. If necessary, disconnect the cable from the clamp.



Fig. 31: Dismantling the cover (similar to picture)

### Check and, if necessary, retighten the element holder screws.

After one week of operation, and then each year, carefully re-tighten the screws (see Torque for Heating Element Screws). Avoid any stress or distortion of the heating elements. Make sure that the element holders do not twist when tightening the screws. If this is ignored, the sensitive heating elements can be damaged.

### Positioning and installing the cover

Place the cover on the furnace housing and fix it in place with the screws that were previously removed.



Fig. 32: Installing the cover (similar to picture)

### Installing the exhaust air tube

Carefully slide the exhaust air tube into the opening. The top of the exhaust air tube must sit on the furnace cover. Reinstall the protective metal sheet of the exhaust air tube with the screws that were previously removed.

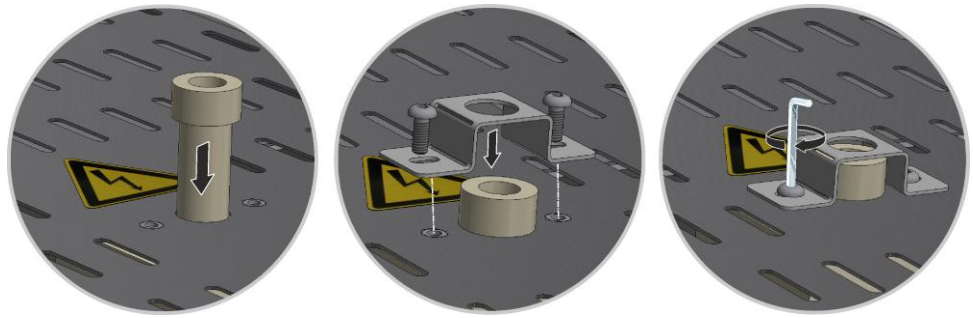

Fig. 33: Installing the exhaust air tube (similar to picture)

### Commissioning

Insert the mains power connector (see chapter "Connection to the Mains Electricity"), then switch on the power switch and check the function of the furnace (see chapter "Operation").

## 7.6 Cleaning Products



Carry out the procedure to switch off the furnace (see "Operation"). Then remove the power plug from the socket. Allow the furnace to cool naturally.

Use commercial cleaning products that are either water-based or non-flammable and free of any solvents to clean the housing. Use a vacuum cleaner for the interior.

### Pay attention to the labeling and information on the cleaning product packaging.

Wipe the surface with a damp, lint-free cloth. You may also use the following cleaning products:

This list must be completed by the operator.	
Component and position	Cleaning product
Outer surfaces (frame)*	Use commercial cleaning products that are either water-based or non-flammable and free of any solvent*
Outer surfaces (stainless steel)	Stainless steel cleaner
Interior	Carefully clean with a vacuum cleaner (pay attention to the heating elements)
Insulation materials	Carefully clean with a vacuum cleaner (pay attention to the heating elements)
Door seal (if present)	Use commercial cleaning products that are either water-based or non-flammable and free of any solvent
Instrument panel	Wipe the surface with a damp, lint-free cloth (e.g., glass cleaner)

\*You must ensure that the cleaning product does not damage the water-soluble, environmentally safe paint (test the product on an interior, concealed area).

Clean quickly to protect the surfaces.

Remove the cleaning product completely from the surfaces by wiping them with a damp, lint-free cloth.

After cleaning, check all supply lines and connections for leaks, loose connections, abrasion and damage; rectify any defects immediately.

Observe the “Environmental Regulations”.



**Note**

The furnace, the furnace chamber and attached components must **NOT** be cleaned with a high-pressure cleaner.

## 8 Malfunctions

Work on the electrical system may be done only by qualified, authorized electricians. Operators may only rectify malfunctions that are obviously due to operating errors.

Call your local electrician for malfunctions that you cannot localize.

If you have any questions, problems, or requirements, contact Nabertherm GmbH. By mail, phone, or e-mail -> See "Nabertherm Service".

Phone advice is free and non-binding for our customers – all you pay is the phone costs.

In case of mechanical damage, send an email containing the above information and a digital photo of the damaged part and a photo of the complete furnace to the following address:

-> see "Nabertherm Service".

If a malfunction cannot be rectified with the described solutions, contact our service hotline directly.

Have the following information at hand when you phone. This makes it easier for our customer service to answer your questions.

### 8.1 Error Messages of the Controller

ID+ Sub-ID	Text	Logic	Remedy
<b>Communication error</b>			
01-01	Bus zone	Communication connection to a control module disrupted	Check that the control modules are firmly attached LEDs on the control modules red? Check the cable between the control unit and the control module Plug of the connection cable not plugged correctly into the control unit
01-02	Bus communications module	Communication connection to the communications module (Ethernet/USB) disrupted	Check that the communications module is firmly attached Check the cable between the control unit and the communications module
<b>Sensor error</b>			
02-01	TC open		Check thermocouple, thermocouple terminals and cable Check contacts of the thermocouple cable in plug X1 on the control module (contacts 1+2)
02-02	TC connection		Check the thermocouple type that has been set Check poles of thermocouple connection
02-03	Reference point error		Control module defective

<b>ID+ Sub-ID</b>	<b>Text</b>	<b>Logic</b>	<b>Remedy</b>
02-04	Reference point too hot		Temperature in the switchgear too high (approx. 70 °C) Control module defective
02-05	Reference point too cold		Temperature in the switchgear too low (approx. - 10 °C)
02-06	Encoder disconnected	Error at the 4-20 mA input of the controller (<2 mA)	4-20 mA – check sensor Check the connection cable to the sensor
02-07	Sensor element defective	PT100 or PT1000 sensor defective	Check PT sensor Check connection cable to the sensor (cable break/short circuit)
<b>System error</b>			
03-01	System memory		Error after firmware updates <sup>1)</sup> Defective control unit <sup>1)</sup>
03-02	ADC error	Communication between AD converter and controller disrupted	Replace control module <sup>1)</sup>
03-03	File system defective	Communication between display and memory chip disrupted	Replace control unit
03-04	System monitoring	Program execution on the control unit defective (Watchdog)	Replace control unit USB flash drive removed too soon or defective Switch controller off and on again
03-05	Zone system monitoring	Program execution on a control module defective (Watchdog)	Replace control module <sup>1)</sup> Switch controller off and on again <sup>1)</sup>
03-06	Self-test error		Contact Nabertherm Service <sup>1)</sup>
03-07	Analog output / wrong voltage at output	Measured value of the output voltage does not correspond to the specified value	Have an electrician carry out the following steps: <ul style="list-style-type: none"> <li>- De-energize the furnace</li> <li>- Disconnect loads at the analog output</li> <li>- Switch the furnace on again and start the program</li> <li>- Error does not re-occur: Replace loads.</li> <li>- Error still present: Replace control module</li> </ul> Contact Nabertherm Service <sup>1)</sup>
<b>Monitoring</b>			
04-01	No heating power	No temperature increase in the ramps when heating output <math>\leq 100\%</math> for 12 minutes and when the temperature setpoint is higher than the current furnace temperature	Acknowledge the error (if necessary, disconnect from the power supply) and check safety contactor, door switch, heating controls and controller. Check heating elements and heating element connections. Lower D value of the control parameters.

ID+ Sub-ID	Text	Logic	Remedy
04-02	Excess temperature	The temperature of the control zone exceeds the max. program setpoint or the maximum furnace temperature by 50 Kelvin (from 200 °C) The equation for the switch-off threshold is: Maximum program setpoint + zone offset of the control zone + charge control offset [Max] (if charge control active) + excess temperature switch-off threshold (P0268, e.g. 50 K)	Check solid-state relay Check thermocouple Check controller  (with 3 minutes delay)
		A program was started at a furnace temperature higher than the maximum setpoint in the program	Do not start the program until the furnace temperature is lower.
04-03	Power failure	The set limit for restarting the furnace was exceeded	If possible, use an uninterruptible power supply
		The furnace was switched off at the main switch during the program	Stop the program on the controller before you switch off the main switch.
04-04	Alarm	A configured alarm was triggered	
04-05	Auto-tune failed	The determined values are implausible	Do not carry out auto-tune at the lower temperature range of the furnace working range
	Battery weak	Time is not shown correctly. A power failure may no longer be handled properly.	Export all parameters to a USB flash drive Replace the battery (see “Specifications”)
<b>Other malfunctions</b>			
05-00	General malfunction	Malfunction in the control module or Ethernet module	Contact Nabertherm Service Provide the service export

Error messages can be reset by acknowledging the message. Contact Nabertherm service if an error message appears again. Recirculation motors (if included) also remain switched on in case of an error until the temperature falls below the set cut-off temperature.

## 8.2 Warnings of the Controller

Warnings are not displayed in the error archive. They are only displayed on the display and in the file of the parameter export. Warning do not generally lead to a program crash.

No.	Text	Logic	Remedy
00	Gradient monitoring	The limit value of the configured gradient monitoring was exceeded	For troubleshooting, refer to “Gradient Monitoring” Gradient set too low

No.	Text	Logic	Remedy
01	No control parameters	No "P" value was entered for the PID parameters	Enter at least one "P" value in the control parameters. It must not be "0"
02	Charge thermocouple defective	No charge thermocouple was determined with the current program and activated charge control	Plug in a charge thermocouple Disable charge control in the program Check the charge thermocouple and its cable for damage
03	Cooling thermocouple defective	The cooling thermocouple is not plugged in or is defective	Plug in a cooling thermocouple Check the cooling thermocouple and its cable for damage  If there is a malfunction in the cooling thermocouple during active controlled cooling, the system switches over to the thermocouple of the control zone.
04	Documentation thermocouple defective	Either no documentation thermocouple or a defective one was determined.	Plug in a documentation thermocouple Check the documentation thermocouple and its cable for damage
05	Power failure	A power failure was determined. There was no program interrupt	None
06	Alarm 1 – Band	The configured band alarm 1 was triggered	Optimize the control parameters Alarm set too narrowly
07	Alarm 1 – Min	The configured min. alarm 1 was triggered	Optimize the control parameters Alarm set too narrowly
08	Alarm 1 – Max	The configured max. alarm 1 was triggered	Optimize the control parameters Alarm set too narrowly
09	Alarm 2 – Band	The configured band alarm 2 was triggered	Optimize the control parameters Alarm set too narrowly
10	Alarm 2 – Min	The configured min. alarm 2 was triggered	Optimize the control parameters Alarm set too narrowly
11	Alarm 2 – Max	The configured max. alarm 2 was triggered	Optimize the control parameters Alarm set too narrowly
12	Alarm – External	The configured alarm 1 at input 1 was triggered	Check the source of the external alarm
13	Alarm – External	The configured alarm 1 at input 2 was triggered	Check the source of the external alarm
14	Alarm – External	The configured alarm 2 at input 1 was triggered	Check the source of the external alarm
15	Alarm – External	The configured alarm 2 at input 2 was triggered	Check the source of the external alarm
16	No USB flash drive inserted		When exporting data, insert a USB flash drive in the controller

No.	Text	Logic	Remedy
17	Import/export of data via the USB flash drive unsuccessful	<p>The file was edited with a PC (text editor) and saved in the wrong format or the USB flash drive was not detected.</p> <p>You want to import data that is not in the import folder on the USB flash drive</p>	<p>Do not edit XML files with a text editor; edit them only in the controller.</p> <p>Format the USB flash drive (format: FAT32). No quick formatting</p> <p>Use a different USB flash drive (to 2 TB/FAT32)</p> <p>When importing, all data must be in the import folder on the USB flash drive.</p> <p>The maximum storage capacity for USB flash drives is 2 TB/FAT32. If you experience problems with your USB flash drive, use a different USB flash drive with maximum 32 GB</p>
	Programs are rejected during the import of programs	Temperature, time or rate are outside the limit values	Import only programs that are suitable for the furnace. The controllers differ as regards the number of programs and segments and the maximum furnace temperature.
	While programs are being imported, "Error occurred" is displayed	The complete parameter set (at least the configuration files) was not stored in the "Import" folder on the USB flash drive	If you deliberately left out files during import, ignore the message. Otherwise, check the completeness of the import files.
18	"Heating blocked"	This message is displayed if a door switch is connected to the controller and the door is open	<p>Close the door</p> <p>Check the door switch</p>
19	Open door	The furnace door was opened while a program was running	Close the door while a program is active.
20	Alarm 3	General message for this alarm number	Check the cause of this alarm message
21	Alarm 4	General message for this alarm number	Check the cause of this alarm message
22	Alarm 5	General message for this alarm number	Check the cause of this alarm message
23	Alarm 6	General message for this alarm number	Check the cause of this alarm message
24	Alarm 1	General message for this alarm number	Check the cause of this alarm message
25	Alarm 2	General message for this alarm number	Check the cause of this alarm message
26	Multi-zone holdback temperature exceeded	A thermocouple that was configured for multi-zone holdback has left the temperature band downward	<p>Check whether the thermocouple is necessary for monitoring.</p> <p>Check the heating elements and their activation</p>

No.	Text	Logic	Remedy
27	Multi-zone holdback temperature undershot	A thermocouple that was configured for multi-zone holdback has left the temperature band upward	Check whether the thermocouple is necessary for monitoring. Check the heating elements and their activation
28	Modbus connection interrupted	The connection to the superordinate system was interrupted.	Check if the Ethernet cables are damaged. Check the configuration of the communication connection

### 8.3 Malfunctions of the Switchgear

Error	Cause	Remedy
<b>Controller does not light up</b>	Controller is switched off	Switch the power switch to "I"
	No power available	Is the power cord plugged into the socket? Check the building fuses. Check the fuse of the controller (if present) and replace it if necessary.
	Check the fuse of the controller (if present) and replace it if necessary.	Switch the power switch on. If the error occurs again, contact Nabertherm Service
<b>Controller displays error</b>	See the separate instructions of the controller	See the separate instructions of the controller
<b>Furnace does not heat</b>	Door / cover is open	Close the door / cover
	The door contact switch is faulty (if present)	Check the door contact switch
	"Delayed Start" is displayed	The program is waiting for the programmed start time. Deselect delayed start above the start button.
	Error in entering the program	Check the heating program (see the separate instructions of the controller)
	Heating element defective	Have this checked by Nabertherm Service or a qualified electrician.
<b>Very slow heating of the heating space</b>	The fuse(s) of the connection is/are defective.	Check the fuse(s) of the connection and replace if necessary. Notify Nabertherm service if the new fuse fails again immediately.
<b>The program does not jump to the next segment</b>	In one TIME segment in the program input, the wait time is set to INFINITE If charge control is activated, the temperature of the charge is higher than the zone temperatures.	Do not set the wait time to INFINITE

Error	Cause	Remedy
	If charge control is activated, the temperature of the charge is higher than the zone temperatures.	The parameter [LOWER BLOCK] must be set to [NO].
<b>The controller module can not be registered on the operating unit</b>	Addressing error of the controller module	Perform a bus reset and re-address the controller module
<b>The controller is not heating in the optimization</b>	No optimization temperature has been set	The temperature to be optimized must be entered (see the separate instructions of the controller)
<b>The temperature rises faster than the controller setting allows</b>	The switch element of the heating unit (semiconductor relay, thyristor or switch contactor) is defective.  Individual defective components inside a furnace cannot be completely ruled out in advance. That is why the controllers and the switchgear units must be equipped with safety facilities. For example, the furnace shuts down the heating unit in response to error message 04 - 02 via an independent contact element.	Have the switch element tested by a qualified electrician and replaced as necessary.

## 9 Spare Parts/Wearing Parts



### Ordering spare parts:

Our Nabertherm Service team is available worldwide. Due to our high vertical range of manufacture, we deliver most spare parts from stock overnight or can produce them with short delivery times. You can order Nabertherm spare parts directly from the factory quickly and easily. Orders can be made by mail, phone, or e-mail -> see "Nabertherm Service".

### Availability of spare parts and wearing parts:

Although Nabertherm has many spare parts and wearing parts in stock, we cannot guarantee the short-term availability of all of them. We recommend that certain parts be ordered in good time. If you need any assistance when selecting spare parts and wearing parts, the staff at Nabertherm will be glad to help you.



#### Note

Original parts and Accessories are designed especially for Nabertherm furnaces. Replace parts only with original Nabertherm parts. Otherwise the warranty will be void. Nabertherm accepts absolutely no liability for damage caused by using parts that are not original Nabertherm parts.



#### Note

Contact our Nabertherm Service for dismantling and installing wearing/spare parts. See "Nabertherm Service". Work on the electrical equipment may be done only by qualified, authorized electricians. This applies also to repairs that are not described here.

## 9.1 Electrical Schematics/Pneumatic Schematics



### Note

The documents included do not always contain the electrical schematics. If you need the respective schematics they can be ordered from Nabertherm Service.

## 9.2 Replacing a Heating Element



### Warning – Danger from electric voltage

Work on the electrical equipment may be done only by qualified, authorized electricians. During work it must be ensured that the furnace and the switching equipment cannot be activated by mistake (pull out the power plug) and that all moving parts in the furnace are secured. DGUV V3 or corresponding national regulations of the respective country of use must be observed. Wait until the furnace and the connected parts have cooled to room temperature.



### Caution – Damage to components!

Heating elements are extremely fragile. Avoid all stress or twisting of the heating elements. If this is not observed, the sensitive heating elements will be destroyed.

### Tools

To change the heating elements, you will need the following tools:

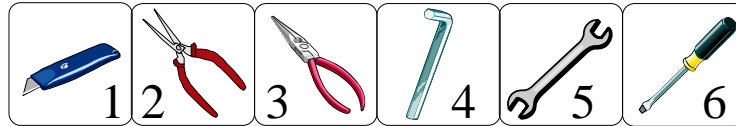

1 Sharp knife, 2 Heating element pliers, 3 Needle-nose pliers, 4 Allen wrench (supplied with furnace), 5 Open-end wrench (SW 7), 6 Slotted screwdriver

Fig. 34: Tools

### Removing the protective plate of the exhaust air tube

Use a suitable tool to undo the screws on the protective plate of the exhaust air tube. Place the screws and the protective plate in a safe place so that they can be reused (disconnect the plug).

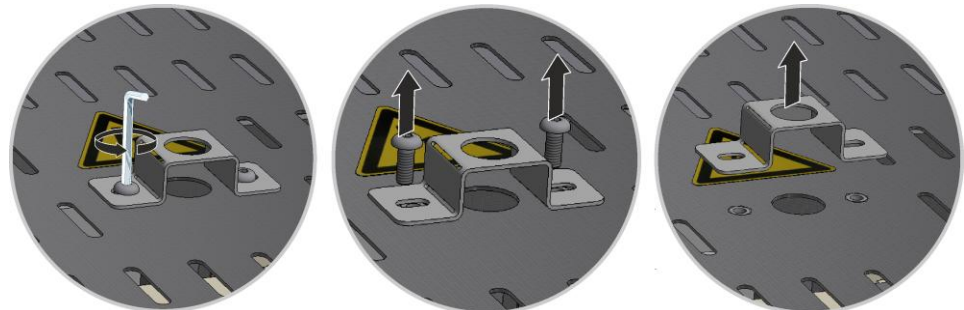

Fig. 35: Removing the protective plate from the exhaust air tube (similar to picture)

### Removing the top cover from the furnace housing

Unscrew all the screws of the panel with a suitable tool and keep them in a safe place for future use.

The number and position of the screws may differ from one furnace model to the next. The furnace may look different than the picture depending on the furnace model and features.

The cover must be lowered onto a soft material (such as foam rubber).

If present, pay attention to the protective ground cable of the back wall to the clamp. If necessary, disconnect the cable from the clamp.



Fig. 36: Dismantling the cover (similar to picture)

### Clamps and connection contact/connection bridge

Carefully open the clamps (1) with the heating element pliers (2) and lift upward. Remove the connection contact or contact bridge (3) upward from the heating element.

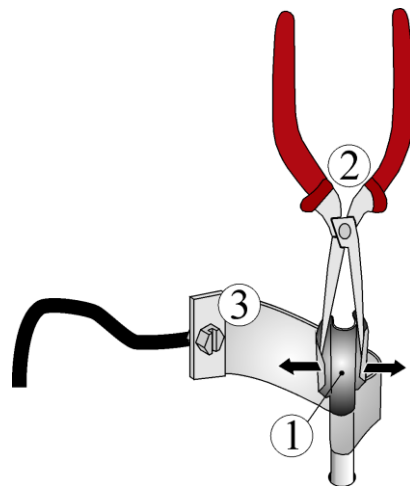
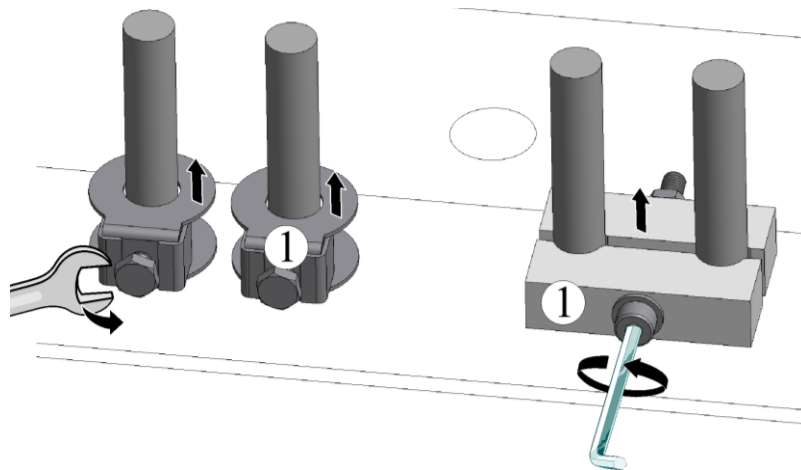

Fig. 37: Clamps and connection contact (similar to picture)

### Element holder and insulation

Carefully undo the screw on the element holder (1) with a suitable tool. Remove the element holder from the heating element. Remove the fiber paper and fiber wool underneath from the gap between the sides of the heating elements.



Variant A

Variant B

Fig. 38: Removing the element holder and insulation (similar to picture)

### Replacing heating elements

Carefully pull heating elements out upwards; do **not** press heating element legs together whilst doing so. Clean heating chamber and passage holes (vacuum out). Carefully insert new heating elements from above. Attention: Pay attention to the correct installation height! See sketch. An assembly support (e.g. foam) between the heating elements and the base of the furnace is helpful.

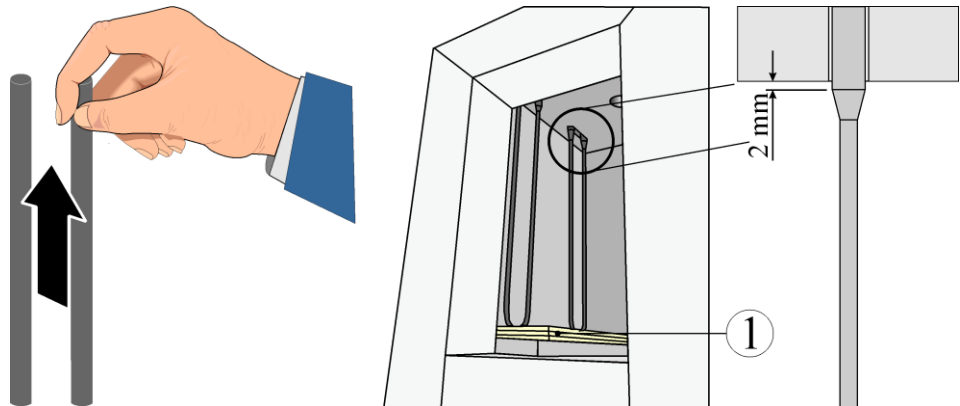

1 = Assembly support (e.g. foam)

Fig. 39: Heating elements (similar to picture)

### Insulation

Fill the gap between the element connection ends with fiber wadding\*. Then place fiber paper\* (approx. 2 mm) on the insulation. If the holes are not filled out, this causes the clamps to overheat with the result that the heating elements break down prematurely.

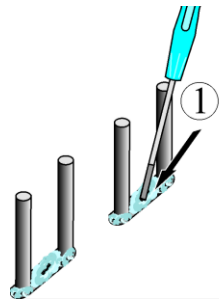
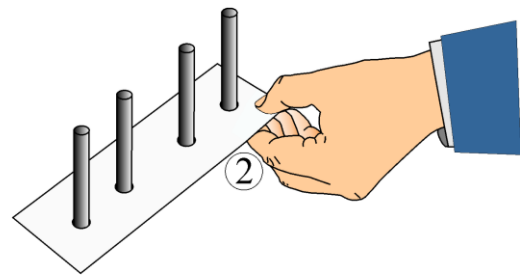

Fig. 40: Fiber wool



Fiber paper

### Assembling the heating elements

Plug the heating element ends on to the element holders (1). **Carefully** tighten the element holders with a suitable tool (see Torque for Heating Element Screws). The screw heads must face outwards. Avoid any stress or distortion of the heating elements. Make sure that the element holders do not twist when tightening the screws. Place the connection contact or connection bridge (2) on to the ends of the heating elements and hold in place with new clamps (3), pay attention that they are correctly positioned to each other. Check the element holders, screws, spring clips and cables.

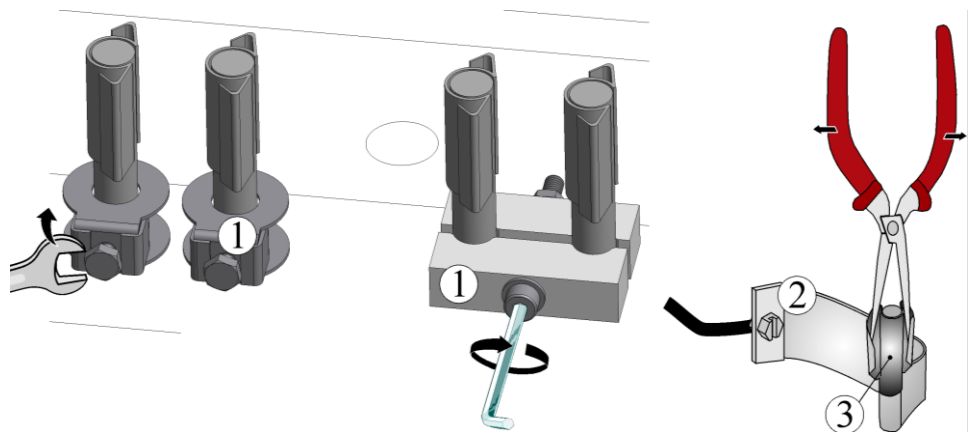

Variant A

Variant B

Fig. 41: Assembling the heating elements (similar to picture)

### Positioning and installing the cover

Place the cover on the furnace housing and fix it in place with the screws that were previously removed.



Fig. 42: Installing the cover (similar to picture)

### Installing the exhaust air tube

Carefully slide the exhaust air tube into the opening. The top of the exhaust air tube must sit on the furnace cover. Reinstall the protective metal sheet of the exhaust air tube with the screws that were previously removed.

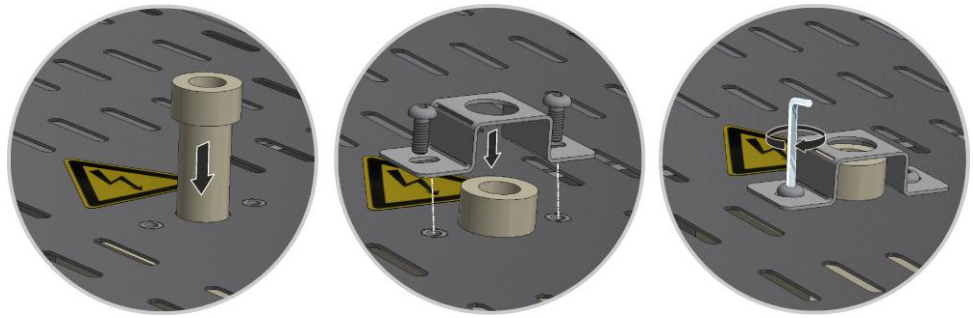
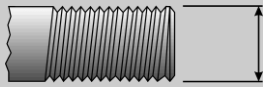



Fig. 43: Installing the exhaust air tube (similar to picture)

### 9.2.1 Tightening Torque for Screw Connections on Heating Elements

Screw tightening torque	
Tighten power cable clamps and screws on the <b>heating elements</b> with a defined torque. If this advice is not followed, the heating elements may be damaged.	
Thread diameter Metric thread (M)	Torque in Nm
	
M 4	2.0
M 5	6.0
M 6	8.0
M 7	14.0
M 8	20.0
M 10	39.0

#### Commissioning

Insert the mains power connector (see chapter "Connection to the Mains Electricity"), then switch on the power switch and check the function of the furnace (see chapter "Operation").



#### Note

Do not forget to remove the assembly support/assembly aid from the furnace chamber.



#### Note

\*) = Enclosed with spare part delivery.

### 9.3 Replacing a Thermocouple



**Warning – Danger from electric voltage**

Work on the electrical equipment may be done only by qualified, authorized electricians. During work it must be ensured that the furnace and the switching equipment cannot be activated by mistake (pull out the power plug) and that all moving parts in the furnace are secured. DGUV V3 or corresponding national regulations of the respective country of use must be observed. Wait until the furnace and the connected parts have cooled to room temperature.



**Caution - damage to components!**

Thermocouples are extremely sensitive to breakage. Any strain on or rotation of the thermocouples must be avoided. Failure to observe this rule will lead to the immediate destruction of the sensitive thermocouples.

**Tools**

To change the thermocouple, you will need the following tools:



1 Allen wrench (supplied with furnace), 2 Slotted screwdriver, 3 Phillips screwdriver

Fig. 44: Tools

**Removing the protective plate of the exhaust air tube**

Use a suitable tool to undo the screws on the protective plate of the exhaust air tube. Place the screws and the protective plate in a safe place so that they can be reused (disconnect the plug).

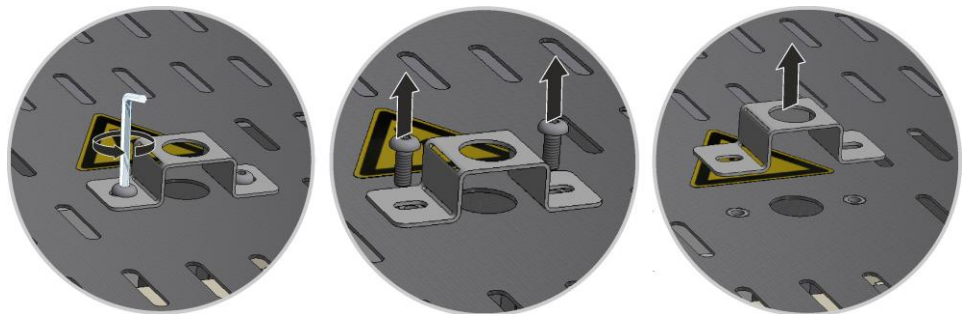

Fig. 45: Removing the protective plate from the exhaust air tube (similar to picture)

**Removing the top cover from the furnace housing**

Unscrew all the screws of the panel with a suitable tool and keep them in a safe place for future use.

The number and position of the screws may differ from one furnace model to the next. The furnace may look different than the picture depending on the furnace model and features.

The cover must be lowered onto a soft material (such as foam rubber).

If present, pay attention to the protective ground cable of the back wall to the clamp. If necessary, disconnect the cable from the clamp.



Fig. 46: Dismantling the cover (similar to picture)

### Replacing the thermocouple

First slacken the two screws (A) from the thermocouple connection. Slacken screw (B) from thermocouple retaining plate and pull thermocouple out upwards. Push a new thermocouple carefully into the thermocouple channel (C) and assemble and connect in reverse order. Attention must be paid to the correct polarity of the electrical connections (D)\*.

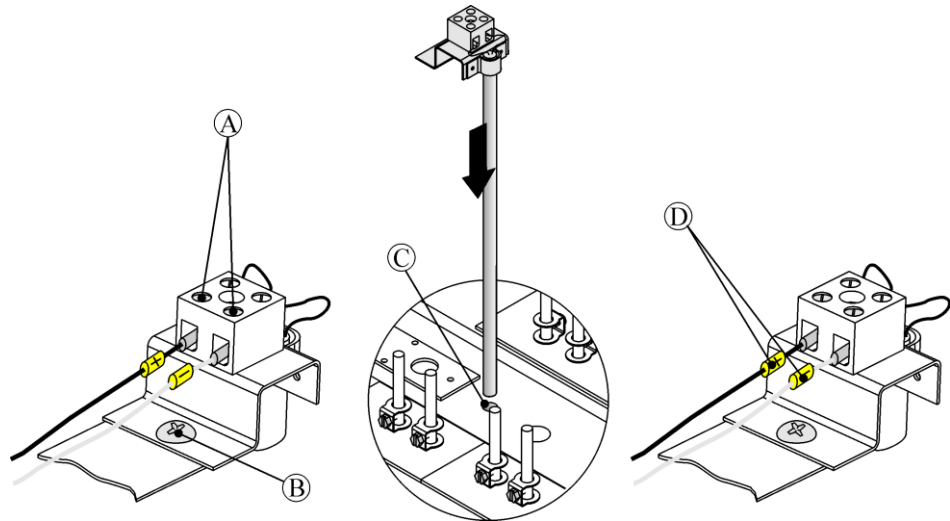

Fig. 47: Replacing the thermocouple (similar to picture)

#### Note

\*) The connections of the connecting lines from the thermocouple to the controller are labeled with  $\oplus$  and  $\ominus$ . It is absolutely essential to observe the correct polarity.

$\oplus$  to  $\oplus$        $\ominus$  to  $\ominus$

### Positioning and installing the cover

Place the cover on the furnace housing and fix it in place with the screws that were previously removed.



Fig. 48: Installing the cover (similar to picture)

### Installing the exhaust air tube

Carefully slide the exhaust air tube into the opening. The top of the exhaust air tube must sit on the furnace cover. Reinstall the protective metal sheet of the exhaust air tube with the screws that were previously removed.

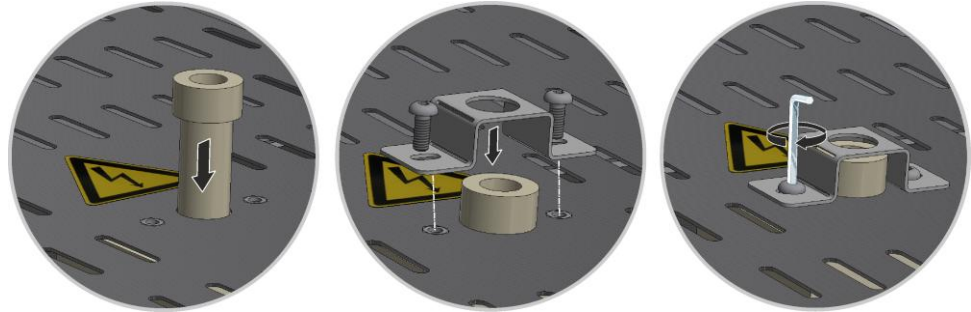

Fig. 49: Installing the exhaust air tube (similar to picture)

### Commissioning

Insert the mains power connector (see chapter "Connection to the Mains Electricity"), then switch on the power switch and check the function of the furnace (see chapter "Operation").

## 9.4 Replacement/Readjustment of the Door Insulation Structure



### Warning – General hazards!

Work on equipment may be carried out only by qualified, authorized personnel. During work, the furnace/switchgear must be kept voltage-free to prevent accidental start-ups (**pull the power plug**) and all movable parts of the furnace must be secured. Observe DGUV V3 or the corresponding national regulations in the country where the equipment is used. Wait until the furnace and the connected parts have cooled to room temperature.

### Tools

The following tools are required to replace/readjust the complete door insulation structure.



Allen wrench

Fig. 50: Tools

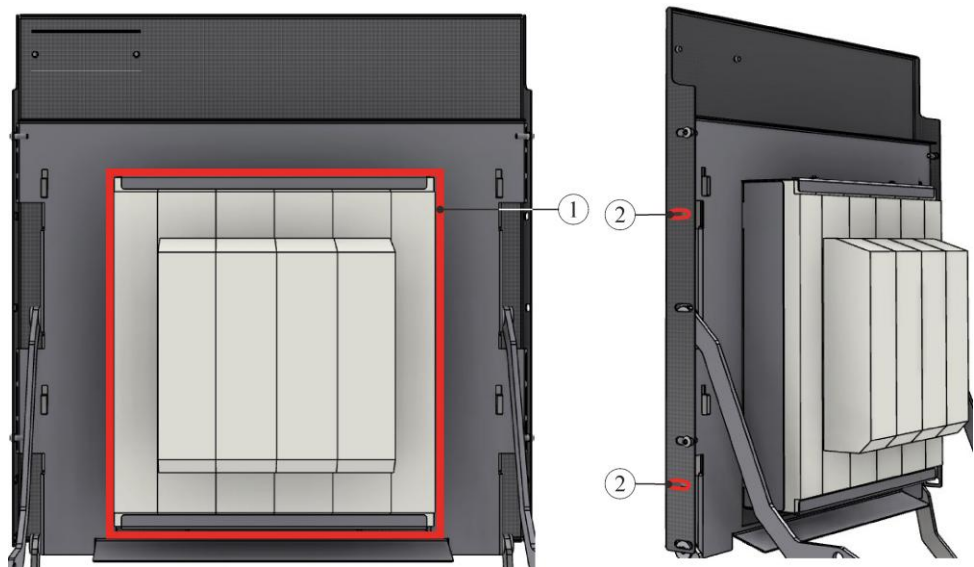

Fig. 51: Replacing/adjusting the door insulation structure (similar to picture)

Item	Quantity	Name
1	1	Door insulation – complete insulation module
2	4	Access to the screws

Fig. 52: Door insulation construction

1. Carefully swing the lift door upward. Loosen all four hexagon head screws of the door insulation module (1) through the access points (2). Then, pull the module out.
2. Reattach and align the new door insulation module, using the hexagon head screws supplied. The insulation is very fragile. Pay attention to neighboring components. If the door insulation does not sit firmly all around the furnace collar, adjust the insulation module, using the hexagon head screws.



**Note**

In Germany, the general accident protection guidelines must be observed. The accident prevention regulations applicable in the country where the furnace is installed must be observed.

## 9.5 Fuse on the Outside of the Switchgear

If a device does not work when connected to a snap-in socket, this may be due to a defective fuse. A fuse is located on the back of the furnace next to the power cable connection. This fuse protects the additional snap-in socket. When inserting a new fuse, use a multimeter to make sure that the fuse rating is suitable for the voltage used by your furnace.

	<b>NOTICE</b>
<ul style="list-style-type: none"> <li>• <b>Damage to the furnace and its components</b></li> <li>• <b>Use of a fuse that is NOT suitable for the respective voltage may damage the furnace and its components and is a fire hazard.</b></li> <li>• Use only a suitable fuse type. Check that the fuse type has the correct nominal current value.</li> </ul>	

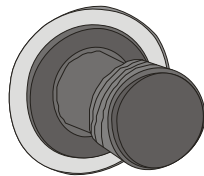

Fuse holder

Fig. 53: The fuse is located in the back wall of the furnace (similar to picture).

- Turn the fuse holder 1/4 of a revolution in a counter-clockwise direction, and then carefully remove the fuse holder with your fingertips.



Fig. 54: Undo and remove the fuse holder (similar to picture)

- Remove the fuse from the fuse holder.
- Replace the faulty fuse with an equivalent fuse.
- Before replacing the fuse, make sure that it has the correct nominal current. For the correct fuse (fuse link), see “Spare Parts/Wearing Parts”.

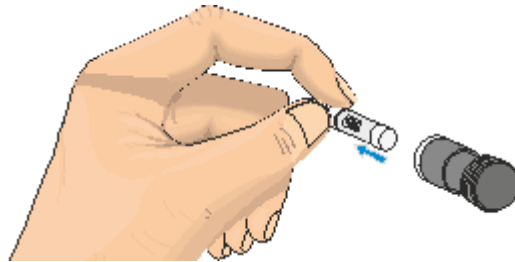

Fuse (fuse link)



Nominal current (Example)

Fig. 55: Remove the fuse (similar to picture)



**Note**

The nominal current is engraved into the metal cap of the fuse or can be found imprinted directly on the fuse.

- Insert the new fuse into the fuse holder. Make sure that the fuse is pushed fully into the holder.
- Replace the fuse holder in the reverse order.

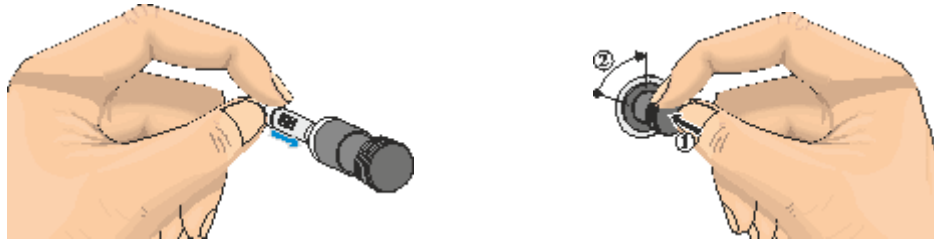

Fig. 56: Insert the fuse (similar to picture)

- Check that the power cable is not damaged. The power cable must not be damaged. Power cables may be replaced only with equivalent, approved cables.
- Reconnect the power cable (see “Connecting the Furnace to the Power Supply”)
- Switch on the furnace power switch (see “Operation”)



**Note**

Assemble the loosened parts in the reverse sequence.

## 9.6 Repairing the Insulation

The insulation of the furnace consists of a very high-quality refractory material. Heat expansion may cause tears in the insulation even after a few heating cycles. However, these have no affect on the function or quality of the furnace. However, if entire "sections" of the insulation come loose, Nabertherm Service must be notified.

## 10 Accessories (Options)

### 10.1 Gas Supply System (Accessories)

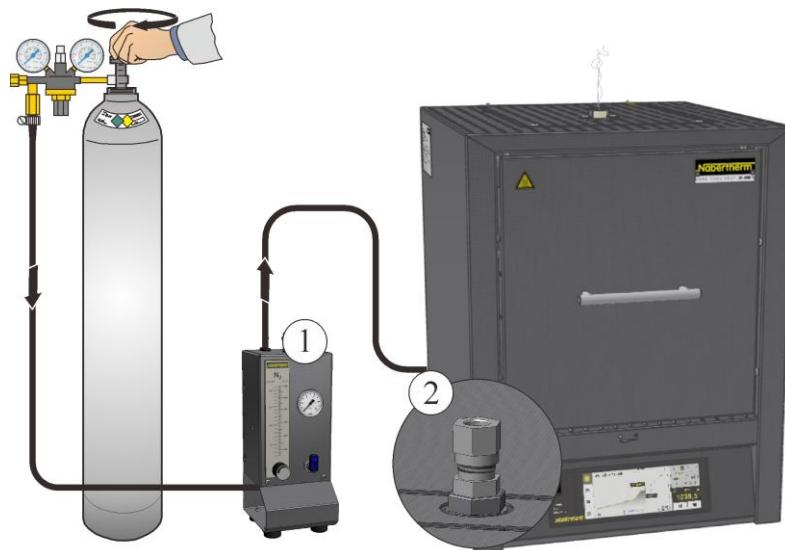

Fig. 57: Connection to the gas supply system (similar to picture)

<b>1</b>	<b>Gas supply system 1</b> for simple protection applications (no vacuum operation). For many applications, this package is an adequate basic version for operation with non-flammable protective gases.
<b>2</b>	Gas injection connection of the furnace

It is the customer's responsibility to provide an exhaust gas system.

### Function Description

The gas supply system permits you to feed **non**-combustible protective and reactive gases (such as: helium (He), argon (Ar), forming gas or nitrogen (N<sub>2</sub>)) into a furnace in a quantity for a defined period.

### Safety

The gas supply system must be checked to ensure that it is in perfect working condition each time before it is used. If there is a defect, immediately stop using the furnace.

During operation, harmful gases and vapors may be released. These must be discharged into the open air in a suitable manner. There is a health hazard if this is not observed.

Only gases whose characteristics are known may be used. If unexpected events occur in the furnace (e.g., a lot of smoke or unpleasant odors), switch it off immediately. Allow the furnace to cool naturally.

Use of the gas supply system in conjunction with flammable gases is permitted only with additional "safety devices".

- Make sure that the installation room is well ventilated and that escaping protective gas does not pose any danger.
- Observe local safety regulations and installation regulations.
- Proper use also includes compliance with the procedures described in these operating instructions for installation, start-up and maintenance.
- The flammability and explosiveness of gases must be taken into account when they are used or are likely to be generated during furnace operation. Particular attention must be paid to ensuring that no corrosive or hazardous substances are produced which escape into the environment.
- It is not permitted to operate the system with power sources, products, operating materials, auxiliary materials, etc. that are subject to the Ordinance on Hazardous Substances or which may in any way harm the health of the operating personnel.
- Hose connections must be checked for leaks and proper fit before each use.
- The gas supply system must be checked for leaks and contamination in the flow meter at regular intervals (use leak detection spray if necessary).
- The function of the ball valve and solenoid valve must be checked at regular intervals.



#### Note

When working with protective gases always make sure that the room is adequately ventilated. Country-specific safety regulations must also be observed.



#### Note

See additional operating instructions for description and function.



#### Warning – Danger of Suffocation

There is a danger of suffocation when process/purge or exhaust gases escape, e.g. as a result of leaks (e.g. at doors, pipes, valves, etc.).

Due to their specific weight gases can displace oxygen. This poses a danger of suffocation. Gases can be flammable or toxic.

Measures: Train operating personnel on safe working procedures, carry portable gas detectors. Switch on the extraction system.

## 10.2 Operation of Compressed Gas Containers

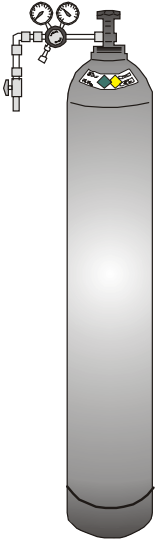

Pressurized gas tanks may be operated only by persons familiar with their handling. Before commencing work, employees must be instructed

in the operation of pressurized gas tanks,  
about the special hazards of handling pressurized gas tanks, and

- what to do in case of accidents or malfunctions. These instructions must be repeated at appropriate intervals.

Pressurized gas cylinders may be placed in work rooms only in the absolutely necessary quantities and in the smallest possible sizes, and only for immediate use.

Pressurized gas cylinders must not be stored in work rooms.

If possible, gas cylinders should be kept in gas cylinder cabinets with an extraction system.

When no gas is being withdrawn, always keep the main valve on the gas cylinder closed. Gas cylinders without attached pressure regulators must not be used without protective caps. Gas hoses must be checked regularly for brittle or porous areas and, if necessary, be replaced immediately.



### Safety measures and appropriate conduct

- Secure pressurized gas tanks against toppling over, impact and heating (e.g. from heater or furnace system).
- At the workplace only have the number of pressurized gas cylinders required to continue working.
- Transport only with cylinder transport trolleys and with protective caps firmly screwed on.
- Wear suitable gloves and if necessary goggles.
- When changing cylinders, always check for leaks at the valves of full and empty cylinders.
- Refilling cylinders is prohibited.
- Do not use force to open valves.
- Sufficiently ventilate areas.
- Smoking and open flames are prohibited.
- Keep fire extinguisher ready.

The operator must prepare operating instructions specifying the hazards occurring in the work room for people and the environment and also specifying the generally required protective measures and codes of conduct. The operating instructions must be written in an understandable form and be available in the work room. The operating instructions must also contain instructions on what to do in case of danger and about first-aid measures.



#### Note

When working with protective gases always make sure that the room is adequately ventilated. Country-specific safety regulations must also be observed.



#### Warning – General Hazards!

If installed improperly, functioning and safety of the system can no longer be guaranteed. The connection must be properly installed and put into operation by qualified personnel.

### 10.3 Separate the Snap-In Coupling (Plug) from the Furnace Housing

With a small flat blade screwdriver carefully push the locking latch (2) upward while pulling the plug (3) out of the coupling (4).

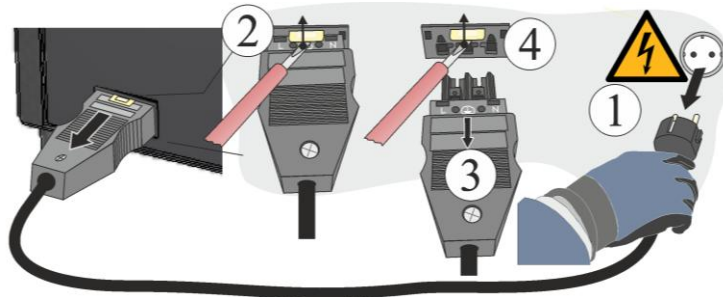

Fig. 58: Separate the snap-in coupling (plug) from the furnace housing (similar to picture)

### 10.4 Over-temperature Limit Controller

Nabertherm GmbH furnaces can be equipped with an over-temperature limiter as protection against excess temperatures inside the furnace.

The over-temperature limiter monitors the temperature inside the furnace. The display shows the trigger temperature that was last set. If the temperature in the furnace exceeds the set trigger temperature, the heating is switched off to protect the furnace and the charge.



Fig. 59: Over-temperature limiter with manual reset 32h8i (similar to picture)

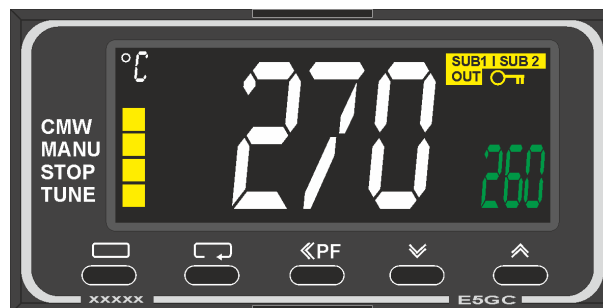



Fig. 60: OMRON E5GC over-temperature limiter (similar to picture)

The over-temperature limiter can vary depending on the furnace model. Furnace models with a maximum temperature up to 1750 C are equipped with the OMRON E5GC. Furnace models with a maximum temperature of 1800 C are equipped with the 32h8.

	 <b>DANGER</b>
	<ul style="list-style-type: none"> <li>• <b>Danger caused by incorrectly entered cut-off temperature at the over-temperature limiter/over-temperature limiter with motor driven reset</b></li> <li>• <b>Risk of fatal injury</b></li> <li>• If, as a result of over-temperature from the charge and/or the operating equipment, a charge is likely to be damaged at this pre-set cut-off temperature of the over-temperature limiter/over-temperature limiter with motor driven reset, or if the charge itself becomes a source of danger for the furnace or its surroundings, the cut-off temperature must be reduced on the over-temperature limiter/over-temperature limiter with motor driven reset to the maximum permissible value.</li> </ul>



**Note**  
See additional operating instructions for description and function.

## 10.5 Electrical Schematics/Pneumatic Schematics



**Note**  
The documents included do not always contain the electrical schematics and pneumatic diagrams.  
If you need the respective diagrams, they can be ordered from Nabertherm Service.

## 11 Nabertherm Service

The Nabertherm Service team is available at all times for furnace maintenance and repair. If you have any questions, problems, or requirements, contact Nabertherm GmbH. By mail, phone, or the Internet.

<b>Mail</b>	<b>Phone or fax</b>	<b>Web or e-mail</b>
Nabertherm GmbH Bahnhofstrasse 20 28865 Lilienthal Germany	Phone: +49 (4298) 922-333 Fax: +49 (4298) 922-129	<a href="http://www.nabertherm.com">www.nabertherm.com</a> <a href="mailto:contact@nabertherm.de">contact@nabertherm.de</a>

**When you contact us, please have the type plate details of the furnace or controller at hand.**

Provide the following details from the type plate:



- ① Furnace model
- ② Serial number
- ③ Article number
- ④ Year of construction

Fig. 61: Example (type plate)

## 12 Shut-Down, Dismantling, and Storage

### To be Completed by the Operator

When the furnace is shut down, the following safety information must be observed to prevent serious injury, damage to property, and damage to the environment.

The furnace may only be shut down by authorized, trained personnel.



The following operating materials/parts are to be disposed of by:

---



---



---

Oils and other substances that are hazardous to water must be completely removed before the furnace is dismantled for recycling or scrap.

Ensure that operating materials, lubricants, and consumables are disposed of in an environmentally compliant manner. Regulations relating to proper waste recycling and disposal must be observed.

The furnace may be lifted only at the intended points.

Use only the specified lifting and securing equipment to lift the furnace/parts.

Consider a total weight of \_\_\_\_\_ kg when choosing \_\_\_\_\_ suitable lifting equipment.

For transportation, consider a permitted floor weight of at least \_\_\_\_\_ kg/m<sup>2</sup>.



Before transporting the furnace, attach the following securing equipment:

---



---



---



#### Note

See “Safety” and “Transportation”.

### 12.1 Transportation/Return Transportation

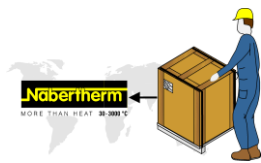

**If you still have the original packaging, this is the safest way to send a furnace.**

Otherwise:

Choose suitable, adequately sturdy packaging. During transportation, packages are often stacked, bumped, or dropped; the packaging acts as external protection for your furnace.

+45°C  
-5 °C



- **Drain all piping and containers before transportation/return transportation (e.g. cooling water). Pump off operating materials and dispose of properly.**
- **Do not subject the furnace to extreme cold or hot temperatures (direct sunlight)**
- **Storage temperature -5 °C to 45 ° (23 °F to 113 °F)**
- **Humidity 5 % to 80 %, non-condensing**
- **Place the furnace on a level floor to prevent distortion**
- **Packaging and transportation may be carried out only by qualified and authorized persons**

If your furnace has transportation securing equipment (see "Transportation Securing"), use this.

Otherwise, in general:

“Fix” and “secure” (adhesive tape) all moving parts and cushion and protect any projecting parts against breakage.

Protect your electronic equipment against moisture and make sure that no loose packaging material can get inside it.

Fill gaps in your packaging with soft but adequately firm material (e.g. foam mats) and make sure that the equipment cannot slide around in the packaging.

**If the goods are damaged during return transportation due to inadequate packaging or some other breach of duty, the costs will be borne by the customer.**

As a rule:

The furnace is sent without accessories, unless the technician expressly requests them.

Enclose a detailed description of the malfunction along with the furnace – this saves the technician time and costs.

Don't forget to enclose the name and phone number of a contact in case there are any questions.



**Note**

Return transportation may only be carried out according to the information given on the packaging or in the transportation documents.



**Note**

Transportation and return transportation **not** covered by a warranty claim are paid for by the customer.

### 13 Declaration of Conformity



### EU Declaration of Conformity

#### High-Temperature Furnaces

<b>Model</b>	LHT 02/16	LHT 04/16	LHT 08/16
	LHT 02/17	LHT 04/17	LHT 08/17
	LHT 02/18	LHT 04/18	LHT 08/18

Name and address of the manufacturer

Nabertherm GmbH  
Bahnhofstr. 20  
28865 Lilienthal, Germany

The above product fulfills the following harmonization regulations of the EU:

- 2006/42/EC (Machinery Directive)
- 2014/30/EU (EMC):
- 2011/65/EU (RoHS)

The following harmonized standards were applied:

- EN 61010-1:2010, EN 61010- 1:2010/A1:2019/AC:2019-04, EN 61010-1:2010/A1:2019
- EN 61000-6-1:2007
- EN 61000-6-3:2007, EN 61000-6- 3:2007/A1:2011/AC:2012, EN 61000-6-3:2007/A1:2011

The manufacturer has sole responsibility for issuing this declaration of conformity. The signatories of the declaration are authorized to compile the relevant technical documents. The address corresponds to the specified address of the manufacturer.

Lilienthal, 21.01.2025



Dr. Henning Dahl  
Vice President R & D

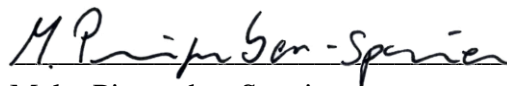

Malte Pirngruber-Spanier  
Department Manager R & D

Terms	Explanation
Smelting	Smelting solid material in furnaces as a result of an increase in temperature is called melting.
Charge	The amount of metal provided for a discontinuously operating furnace in the form of block or circulation material.
Emission	In the sense of the air pollution laws, the air contamination proceeding from a system; in a more general sense, it can also include noise, exhaust heat, odors, water contamination, etc.
Endogas	This is a special <b>protective gas atmosphere</b> of endogas/nitrogen mixtures for the heat treatment of steel and nonferrous metals in industrial furnace systems. A typical gas composition is 20 % CO, 40 % H <sub>2</sub> and the rest N <sub>2</sub>
Exogas	This is a special <b>protective gas atmosphere</b> of exogas/nitrogen mixtures for the heat treatment of steel and nonferrous metals in industrial furnace systems. A typical gas composition is 10 % CO <sub>2</sub> , 5 % H <sub>2</sub> and the rest N <sub>2</sub>
Molybdenum disilicide (MoSi <sub>2</sub> )	This material is characterized by good high-temperature stability and thermal conductivity and by its good oxidation and corrosion resistance at temperatures between 1000 °C and 1600 °C. A thin, adhering protective layer consisting of quartz glass (SiO <sub>2</sub> ), which provides the element with good oxidation resistance, forms on the surface of the element at temperatures over 800 °C. A wire coated with MoSi <sub>2</sub> can be heated until white-hot in air without the formation of molybdenum oxides.
Molybdenum oxide (MoO <sub>3</sub> )	Molybdenum and silicon oxidation takes place at temperatures of around 550 °C. This leads to a yellowish powder consisting primarily of molybdenum oxide (MoO <sub>3</sub> ), which occurs in combination with oxygen.
Oxidation	Oxidation in the narrower and original sense is the chemical reaction of a material with oxygen. The resulting product is an oxide.
Holding mode	Mode of furnaces to hold at a predefined melt bath temperature.
Scale formation	Oxide formation or the formation of surface scale on the metal surface occurs in an oxidizing atmosphere due to a thermal influence (e.g. heat treatment).

## 14 For Your Notes

---

**For Your Notes**

**For Your Notes**

