

Operating Manual

Top Loader

Furnace model

Top 60

Top 160

Top 190

Top 60/R

Top 190/R

Top 220

You can obtain the operating instructions in Spanish or French via the following link or by scanning this QR code: Apps to scan QR codes can be downloaded from the corresponding sources (app stores).



Spanish

<https://nabertherm.com/es/descargas/manuales-de-instrucciones>



French

<https://nabertherm.com/fr/telechargements/manuels-dutilisation>

M01.9089 ENGLISCH

Original instructions

■ **Made**
■ **in**
■ **Germany**

www.nabertherm.com

Copyright

© Copyright by
Nabertherm GmbH
Bahnhofstrasse 20
28865 Lilienthal
Federal Republic of Germany

Reg: M01.9089 ENGLISCH
Rev: 2026-06

No responsibility is accepted for the correctness of this information. We reserve the right to make technical alterations.

1	Safety Information and Intended Use	5
1.1	General Safety Information	5
1.2	Key to the Symbols and Terminology Used in Warnings.....	6
1.3	Intended Use.....	8
1.4	Basic Measures in Case of Emergency.....	9
2	Product Description	10
2.1	Complete Overview of the Kiln.....	11
2.2	Specifications.....	12
2.3	Scope of Delivery	13
3	Transportation, Assembly, Installation Location and Initial Start-Up	14
3.1	Delivery and Transportation	14
3.2	Constructional and Connection Requirements.....	17
3.3	Installation Location	17
3.4	Connecting the Kiln to the Power Supply.....	23
3.5	Initial Start-Up.....	27
3.6	Information about the Insulation.....	28
4	Operation	29
4.1	Controller.....	30
4.2	Opening and Closing the Lid.....	31
4.3	Fresh-Air Flap.....	33
4.4	Loading/Charging.....	34
4.5	Operation of the Manual Zone Control from Model Top 160 Liters (Additional Equipment).....	36
4.6	Potter Tips	36
5	Servicing, Cleaning, and Maintenance	38
5.1	Basic Measures	38
5.2	Working on the Insulation	38
5.3	Regular Maintenance of the Kiln.....	39
6	Malfunctions	44
7	Spare Parts/Wearing Parts	45
7.1	Replacing the Heating Elements.....	45
7.2	Replacing a Thermocouple.....	51
7.3	Replacing the Gas Strut	52
7.4	Replacing Electrical Fuses on the Kiln.....	55
8	Accessories	56
9	Nabertherm Service	56
10	Shut-Down, Dismantling, and Storage	57
11	NABERTHERM LIMITED PRODUCT WARRANTY	57
12	For Your Notes	59

Ceramics Creates Passion.

Trust in Nabertherm!

Nabertherm kilns are the right choice for your hobby, your workshop and your professional use. All of our kilns are hand-made in Germany, using the best available materials.

Our family-owned company has experience in the manufacture of kilns since 1947. We use our valuable earth resources as sparingly as possible to produce your reliable companions in outstanding quality.

Our kilns are characterized by:

- Excellent firing results
- Energy efficiency and economy
- Reliability
- Special ergonomics
- Durability
- 36 months warranty
- Innovation

With Nabertherm, you can be sure of quality, safety and excellent firing results. And with our long-standing network of partners throughout the world, you can rely on specialized customer service when you need it.

For many years, the name Nabertherm has stood for the highest quality standards and durability in kiln construction. To secure that it maintains this position in the future, Nabertherm not only provides a top-quality spare parts service, but also guarantees outstanding customer service. Benefit from our experience in kiln construction.



All the best and enjoy your kiln.

Timm Grotheer
CEO of the Nabertherm Group

1 Safety Information and Intended Use

1.1 General Safety Information

This section contains an overview of the most important safety information. Please also observe the detailed descriptions and other safety information in the subsequent sections.

Installation location and constructional requirements

1. For safe operation, your kiln must be placed in a dry place that is protected against the weather but that is also well ventilated. The temperatures 41 °F to 104 °F (5 °C to 40 °C) must be maintained all year round.
2. Kilns radiate heat when they are operated. Ensure an all-round gap of 40 inches (100 cm) between the kiln and flammable and temperature-sensitive objects. The floor must not be made from flammable material. All flammable materials, such as drapes, plastics, furniture, rugs, etc. must be removed from the area around the kiln.
3. If an automatic extinguishing system is installed at the kiln installation location, ensure that it cannot be activated by the radiated heat. In this regard, also consider whether to open the kiln while it is hot. Observe local construction and fire prevention regulations.
4. The floor must have an adequate load-bearing capacity and be suitable so that the kiln has a secure footing.
5. Access to the kiln must be restricted if the installation location can be accessed by unauthorized persons, children or pets.
6. Do not use an extension cable to connect the kiln. The power cable must be laid so that it does not touch hot parts of the kiln and so that no one can trip over it.
7. The workplace must be properly ventilated. Harmful vapors must be directed from the work room outdoors via professionally installed exhaust air piping.
8. The furnace must not be operated at locations above 6560 ft (2000 meters) above sea level.

Operation

1. Check the kiln before switching it on. If there are external changes that could indicate a fault, the kiln must not be operated. If, during operation, changes take place or the kiln makes strange noises, switch the kiln off for safety reasons.
2. It is important to take care when working with the kiln. During operation, areas around the kiln can become hot and cause burns if they are touched accidentally.
3. The lid must be completely open and secured before you load or unload the kiln. To do this, open the lid until it is secured by the locking bolt at the back of the kiln.
4. The kiln is not suitable for drying. Place only almost dry materials and furniture in the kiln. Objects with a high level of residual moisture can crack, split and cause corrosion on the kiln housing.
5. Do not place flammable materials in the kiln. Remove paper, wood and plastics. Materials that melt, produce flammable gases, explode or release harmful vapors must not be placed in the kiln.
6. Opening a hot kiln at temperatures above 390 °F (200 °C) is not permitted and will lead to increased wear of the insulation, heating elements and the kiln housing. There is also a risk of burning injuries. For your safety and to protect the kiln and your ceramics, we recommend that you do not open the kiln until the program has finished and the kiln has cooled down completely.
7. If the kiln has to be opened before it has cooled completely, you must wear suitable, heat-resistant protective clothing. Make sure that your clothing does not come into contact with hot surfaces. There is a risk that your clothing may catch fire or stick to the surface.
8. The closed lid can be secured with a lock. This is highly recommended if the installation location is accessible to unauthorized persons (such as children).
9. If a serious natural disaster is announced, such as storms, flooding or an earthquake, unplug the kiln or use the circuit breaker to disconnect the kiln from the power supply.

Cleaning, maintenance and repair

1. Before carrying out any repair or maintenance work, pull the plug or use the circuit breaker to disconnect the kiln from the power supply.

2. Work on the electrical equipment may be carried out only by a licensed electrician.
3. Original parts are designed specifically for Nabertherm kilns. Only Nabertherm original parts may be used when replacing components.
4. If a protective device is faulty (no switchgear cover, a faulty door contact switch, for example), do not switch the kiln on; instead, pull the plug or use the circuit breaker to disconnect the kiln from the power supply.

1.2 Key to the Symbols and Terminology Used in Warnings

SAFETY INFORMATION	Draws attention to certain safety-relevant instructions or procedures.
NOTICE	Indicates a hazard that could damage the equipment.
CAUTION	Indicates a hazardous situation that could result in minor or moderate injury.
WARNING	Indicates a hazardous situation that could result in death or serious or irreversible injury.
DANGER	Indicates a hazardous situation that will result in death or serious injury.

Information Symbols in the instructions



General

This symbol draws attention to important rules that must be observed. Mandatory action signs protect people against injury and show what needs to be done in certain situations.



Important information for operators

This symbol draws the operator's attention to important information in the operating instructions that must be observed.



Pull the plug to disconnect the kiln from the power supply

This symbol tells the operator to pull the plug to disconnect the kiln from the power supply (depends on the model – no circuit breaker installed).



Disconnect the kiln from the power supply by using the circuit breaker

This symbol tells the operator to disconnect the kiln from the power supply by using the circuit breaker (depends on the model – no plug installed).



Wear appropriate protective gloves

This symbol tells the operator to wear appropriate protective gloves. To be worn when installing the kiln.



Wear appropriate protective footwear

This symbol tells the operator to wear appropriate protective footwear. To be worn when installing the kiln.



Wear appropriate protective clothing

An apron protects your clothing and also prevents burns.



Lift with several people

This symbol draws the personnel's attention to the fact that this equipment may only be lifted and moved to its final destination by several people.



Maintain a safe distance

This symbol tells personnel to maintain an all-round distance to flammable or temperature-sensitive objects.



General hazards

This symbol draws the operator's attention to a general hazard.



Danger from hot surfaces and burning

You may not always realize that surfaces, such as system components, kiln walls, or materials are hot. Do not touch the surface.



Danger from hot surfaces and burns

You may not always realize that surfaces, such as system components, kiln walls, or materials are hot. Do not touch the surface.



Warning – electric shock

This symbol warns the operator that there is a risk of an electric shock if the following warnings are ignored.



Danger when lifting heavy loads

This symbol warns the operator of the potential dangers when lifting heavy loads. Ignoring this can lead to injury.



Fire hazard

This symbol warns operators of the danger of fire if the following information is not followed.



Warning about sharp objects

This symbol warns the operator about the risks of cutting injuries due to sharp or pointed objects to prevent minor or serious injuries.



Risk of explosion

This symbol warns about explosive substances. Caution is required when working with or near explosive substances.



Do not clean with water

This symbol warns the operator that water or cleaning products must not be poured over the kiln. A high-pressure cleaning device must also not be used.



Important information for operators

This symbol tells the operator that small parts are NOT suitable for children under 3 years of age or for persons who tend to put inedible things in their mouth. There is a risk of suffocation.



Important information for operators

This symbol tells the operator that the kiln or attached parts, such as the controller, must NOT be exposed to direct sunlight or hot surfaces.

1.3 Intended Use

Kilns in the TOP range are electrically heated chamber kilns for firing ceramics. Firings are started when the kiln is cool and end when the kiln is cool again. The lid may be opened only at temperatures below 390 °F (200 °C).

Target group

The instructions are intended for operators and professionals. Repairs and maintenance work on the electrical equipment may be carried out only by a licensed electrician.

This kiln may be used by children aged 8 years and above and by persons with reduced physical, sensory or mental capabilities or lack of experience and knowledge, provided they are supervised or have received instructions in using the kiln safely and they understand the hazards involved.

The following are not intended use:

- Deviating use, such as the processing of products other than those intended and the handling of hazardous substances or materials or substances that are hazardous to health.
- Drying any objects. Only almost dry material and aids may be placed in the kiln.
- Heating food, wood, grains, animals, etc.
- Operating the kiln with removed or modified safety equipment. Improper modifications can pose a risk to people, the environment and the kiln.
- Ignoring installation information and safety regulations.
- Operation with power sources, products, operating materials, auxiliary materials, etc., which are subject to hazardous substance regulations or which may in any way harm the health of the user.

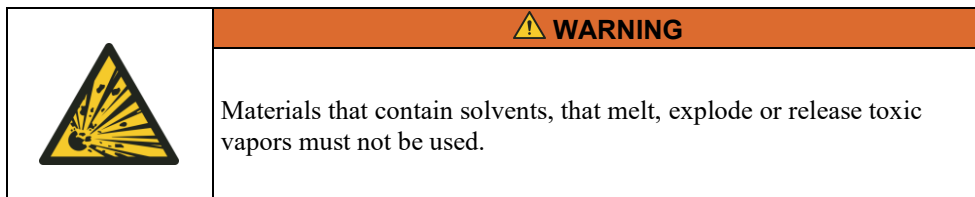

The operator must ensure the following:

- All required measures have been taken to ensure safe operation.
- Harmful gases released during firing are removed from the installation location in a suitable manner. Harmful gases can occur from firing the clay or glaze.
- The properties of materials used in the kiln are known and the materials do not create a hazard. Materials that could damage the insulation include: alkalis, alkaline earths, metal vapors, metal oxides, chlorine compounds, phosphorous compounds, and halogens. If ignored, harmful gases can be released and damage the kiln.
- The kiln is operated in a perfect, working condition and, in particular, the safety equipment (lid switch that switches the heating off if the lid is opened, for example) is checked regularly to ensure that it works as intended.
- Required protective equipment is available. Example: protective gloves, suitable apron, etc.
- These operating instructions are to be kept near the kiln. These instructions must be available at all times for anyone working with or on the kiln.
- Signs and stickers are easily legible. Damaged or unreadable signs must be replaced immediately.
- Persons who operate the kiln are instructed in all issues associated with safety and environmental protection, they know the content of the operating instructions and understand the safety information.

1.4 Basic Measures in Case of Emergency

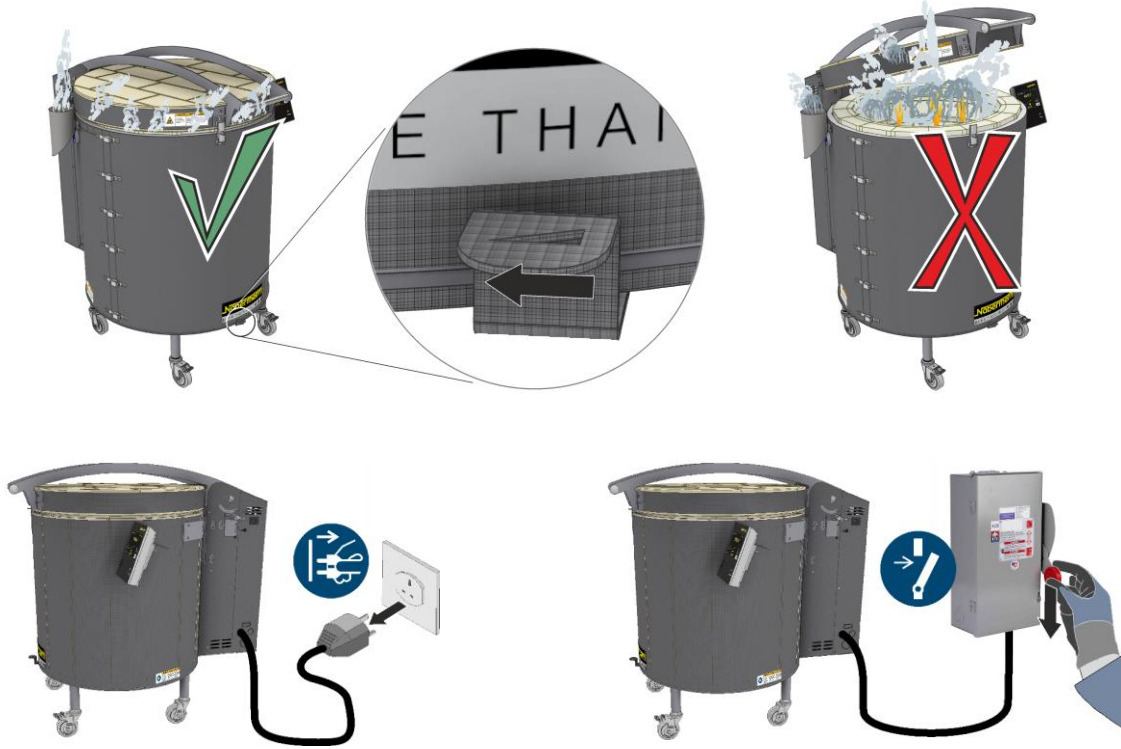

In case of unexpected incidents in the kiln (for example, a lot of smoke), switch the kiln off immediately and keep the lid closed. Allow the kiln to cool with the power disconnected.

Disconnect the kiln from the power supply immediately by pulling the plug or via the circuit breaker.



Kiln with plug

Kiln with circuit breaker (not included in scope of delivery)

	<p style="text-align: center;">NOTICE</p> <p>Do not restart the kiln. Open the lid only when the kiln has cooled completely. Before restarting the kiln, check the content of the kiln and the kiln itself for faults.</p>
	<p style="text-align: center;">WARNING</p> <p>In case of fire, keep the lid closed. Keep doors and windows closed. Immediately notify the fire department, regardless of the extent of the fire. Leave the installation location.</p>

2 Product Description

This electrically heated kiln is a high-quality product. With good care and maintenance, reliable operation is guaranteed for many years. One basic requirement is that the kiln is used for the purposes for which it was intended.

During development and production of the kiln, high priority was placed on safety, functionality, and economy.

Kilns in the Top range are electrically heated chamber kilns for firing ceramics.

Top loaders in the Top range are suitable for firing temperatures up to 2300 °F (1260 °C) and can be fired up to 2408 °F (1320 °C).

Other features of this product are:

- Heating elements protected in grooves, heating from all sides
- Lid with adjustable quick-release lock and padlock
- Ergonomic opening and closing of the lid supported by gas struts
- Automatic lid lock when open
- Controller can be removed for convenient operation
- Solid state relays ensure low-noise heater operation
- Type S thermocouple with protective tube, protected against mechanical damage
- Lid interlock safety switch
- Multi-layer, energy-saving insulation
- Stainless steel housing
- Controller AC590 with touch operation (50 programs, each with 40 segments) and ceramics wizard to help you create programs easily
- Wear-free lid seal
- Adjustable air inlet in kiln floor for good ventilation and extraction
- Exhaust air outlet on kiln side with connection for a 3.2-inch (80 mm) diameter pipe
- Sturdy, locking castors for easy movement of the kiln
- Only insulation materials that are not classified according to Regulation (EC) No. 1272/2008 (CLP) are used. This means that no aluminum-silicate wool, also known as RCF fiber, is used, which is classified and may be carcinogenic.
- Very good access for maintenance
- Additional equipment from TOP 160 floor heating for very good temperature uniformity

2.1 Complete Overview of the Kiln

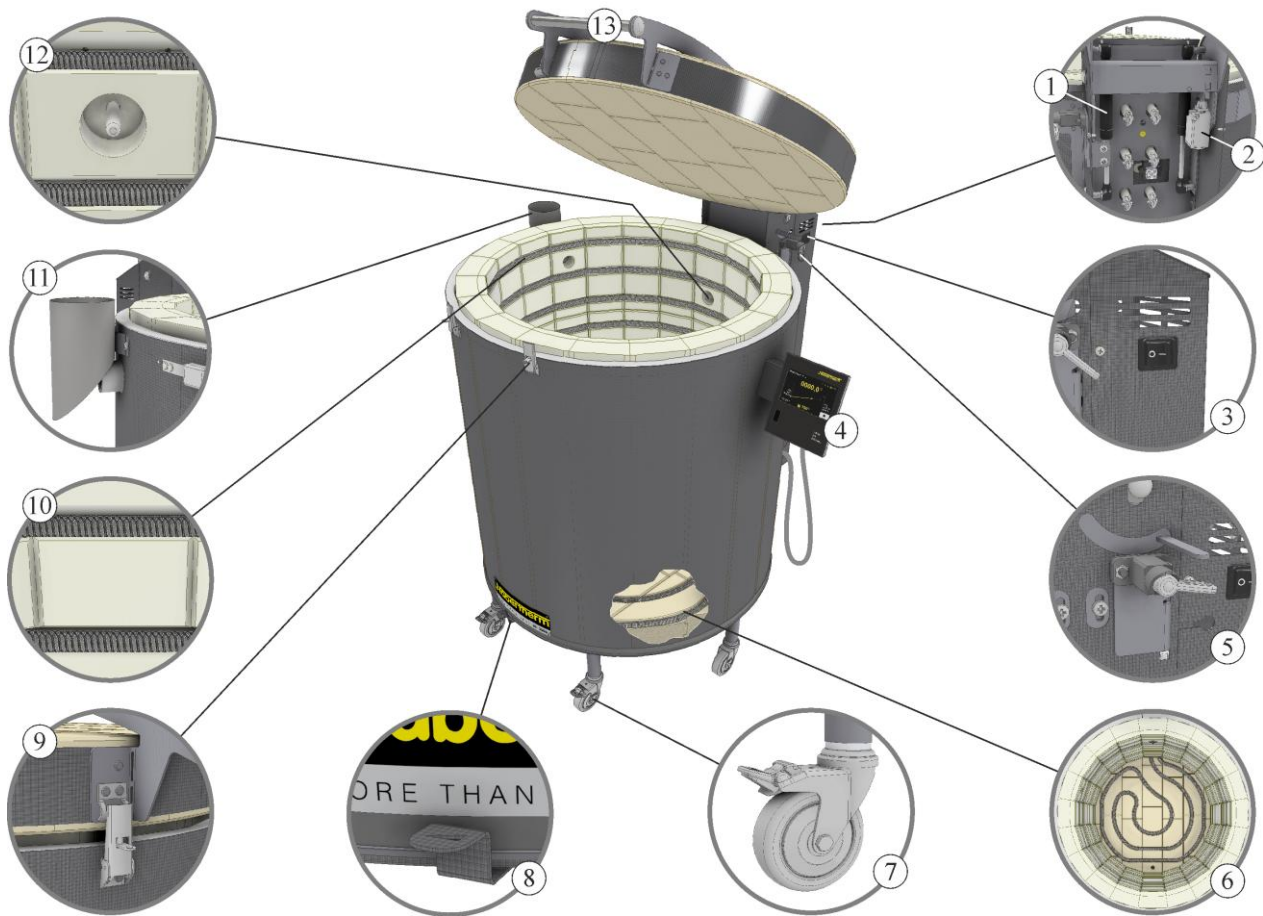

No.	Name
1	Ergonomic opening and closing of the lid supported by gas struts
2	Lid contact switch (heating is switched off if the lid is opened)
3	Power switch (to switch the kiln on and off)
4	Removable controller with touch operation
5	Automatic lid lock when open
6	Floor heating from Top 160 (additional equipment)
7	Castors
8	Adjustable air inlet in kiln floor for good ventilation and extraction
9	Quick-release fastener, door can be locked with a padlock
10	Heating elements, protected in grooves
11	Bypass to connect an exhaust air pipe
12	Thermocouple protected in the insulation
13	Handle to raise the lid

2.2 Specifications

Model	Max. D	Inner dimensions in inches			Volume cu ft	Outer dimensions in inches			Weight lbs	Max. charge weight lbs	Power kW	Electrical connection	Electricity A	Fuse A	Cable AWG (American Wire Gauge)	NEMA plug
		°F	w	d		h	W	D								
Top 60	2408	Ø 16	17.8	2.11	23.6	35.0	35.4	163	66	3.7	208 V 2/PE	17.6	30	10	6-30	
												240 V 2/PE	15.2	20	12	6-20
Top 60/R	2408	Ø 16	17.8	2.11	23.6	35.0	35.4	163	66	5.6	208 V 2/PE	26.7	50	8	6-50	
												240 V 2/PE	23.2	30	10	6-30
												208 V 3/PE	26.7	50	8	15-50
												240 V 3/PE	23.2	30	10	15-30
Top 160	2408	Ø 23	22.4	5.65	30.7	42.5	41.3	269	176	9.1	208 V 2/PE	43.6	60	4	F	
												240 V 2/PE	37.7	50	8	6-50
												208 V 3/PE	25.3	50	8	15-50
												240 V 3/PE	21.9	50	8	15-50
Top 190	2408	Ø 23	26.7	6.70	30.7	42.5	45.6	298	176	9.96	208 V 2/PE	47.9	60	6	F	
												240 V 2/PE	41.5	60	6	F
												208 V 3/PE	27.8	50	8	15-50
												240 V 3/PE	24.1	50	8	15-50
Top 190/R	2408	Ø 23	26.7	6.70	30.7	42.5	45.6	297	176	13.6	208 V 2/PE	65.2	100	3	F	
												240 V 2/PE	56.5	80	4	F
												208 V 3/PE	37.7	50	8	15-50
												240 V 3/PE	32.7	50	8	15-50
Top 220	2408	36.6	23.0	17.7	7.76	44.0	41.3	37.4	340	15.1	208 V 2/PE	72.4	100	3	F	
												240 V 2/PE	62.7	80	4	F
												208 V 3/PE	41.9	60	6	F
												240 V 3/PE	36.3	50	8	15-50

F: Fixed connection

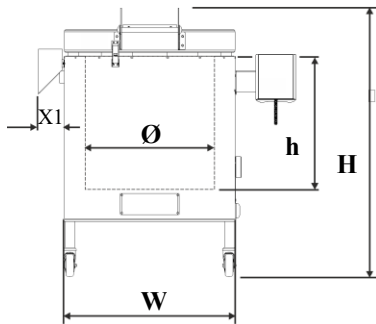

Top 60 – 190

$X1 = 3.54$ inches (90 mm)

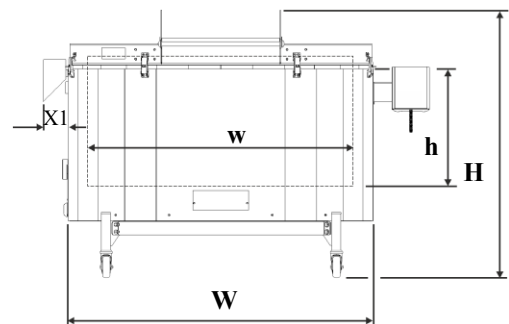

Top 220







Electrical data		
	Voltage (V):	See type plate on kiln
	Frequency (Hz):	60 Hz
	Amperage (A):	See type plate on kiln
Protection type		IP20
Ambient conditions for electrical equipment	Temperature:	+41 °F (+5 °C) to +104 °F (+40 °C)
	Humidity:	Max. 80% non-condensing
Emissions		Continuous sound level <60 db(A)
Measurement accuracy	Temperature:	< ±3 Kelvin
Altitude of the installation location	The furnace may be operated only at altitudes below 6560 ft above sea level.	

Name of Model	Explanation
Top 60/R	Top = Top loader, round/oval
Top 60/R	60 = 2.1 cft kiln chamber
	160 = 5.7 cft kiln chamber
	190 = 6.7 cft kiln chamber
	220 = 7.8 cft kiln chamber
Top 60/R	R = rapid



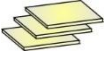



 MORE THAN HEAT 30-3000 °C		
Nabertherm GmbH Bahnhofstr. 20, 28865 Lilienthal/Bremen, Germany Tel +49 (04298) 922-0, Fax +49 (04298) 922-129 contact@nabertherm.de www.nabertherm.de		
Top 160	SN 123456	01/2025
TOP1034-N3	2408 °F	 7,0 kW
-	240 V 3/N/PE~	-
60 Hz	30,4 A	7,0 kW
Made in Germany		

2.3 Scope of Delivery

Components	Quantity
 Kiln model Top ...	1
 Bypass connection	1
 Ceramic tiles (691600956)	3
 Castors	4 to 6 depending on size of kiln
 Hex key	1
 Kiln operating instructions	1
 Controller operating instructions	1

Components		Quantity
Accessories		Quantity
	Frame extension ¹⁾ (for Top 60 and Top 60/R models)	See shipping documents
	Shelf/shelves	See shipping documents
	Prop(s)	See shipping documents

3 Transportation, Assembly, Installation Location and Initial Start-Up

	⚠ CAUTION	
	When the kiln is being lifted, parts of the kiln or the kiln itself could topple over, slip, or fall down. Wear suitable protective gloves and safety footwear.	
	⚠ CAUTION	
	Risk of injury from lifting heavy loads. You could injure your back. Have several people carry the kiln or use a suitable pallet truck.	

3.1 Delivery and Transportation

Check that everything is complete

Compare the delivered items with the delivery note and the purchase order documents. Immediately notify the carrier and your specialist dealer of any missing parts or damage due to inappropriate packaging or transportation, as complaints received at a later date cannot be acknowledged.

Transportation with a pallet truck

1. Observe the permitted load-carrying capacity of the pallet truck.
2. Our kilns are delivered ex works on wooden pallets to facilitate unloading. Kilns may be transported only in packaging and with suitable equipment to prevent any damage. Remove the packaging only when the kiln is at its final location. When transporting the kiln, make sure it is secured against sliding, toppling over, and damage. The kiln should be transported and installed by at least two persons.
3. Push the pallet truck beneath the pallet. Make sure that the pallet truck is pushed completely beneath the pallet.
4. Carefully raise the pallet, paying attention to its center of gravity.
5. Check that the pallet sits securely, use transport aids if required. Move the pallet truck carefully, slowly and with forks in the lowest position. Special care is required on sloping routes.
6. At the installation location, carefully lower the pallet.

Unpacking



The kiln is packaged carefully to prevent damage during transportation. Make sure that you remove all packaging material (also inside the kiln chamber). Keep the packaging and transportation securing equipment in case it is needed for future transportation or storage.



1. Check the transport packaging for possible damage.
2. Remove straps from the transportation packaging.
3. Undo the screws and remove the wooden frame from the cardboard box (if present 3a)
4. Lift the cardboard box and remove it from the pallet. Compare the delivered items with the delivery note and the purchase order documents.
5. The pallet contains additional accessories in separate packaging.
6. Remove the top protective film (A) from the kiln.
7. To protect the insulation, protective film (B) is placed between the kiln and the lid; this must be removed.

	<p>⚠ WARNING</p>
<p>Do not allow children to play with packaging parts. There is a risk of suffocation from plastic films and plastic parts. Small parts are not for children under 3 years of age or persons who tend to put inedible things in their mouth.</p>	

Transporting the kiln

	⚠ CAUTION	
	<p>There is a risk of cutting injuries to the hand at the bottom edge of the housing. Wear cut-resistant gloves.</p>	
	⚠ CAUTION	
	<p>Risk of injury from lifting heavy loads. You could injure your back. Have several people carry the kiln or use a suitable pallet truck.</p>	

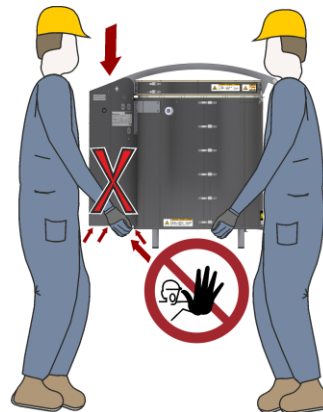
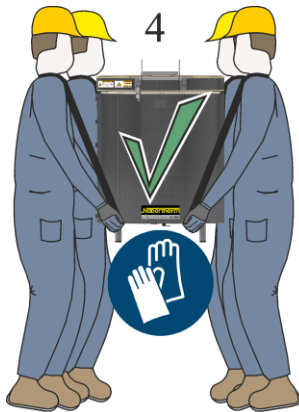

1. To carry the kiln, place your hands beneath the sides (near the feet) and make sure that you have a good grip. Wear protective gloves when installing the kiln. Keeping your back straight, lift the kiln from the pallet and carefully lower it at the place where it is to be installed. The kiln should be transported by at least 2 people.



2. If transporting the kiln with a forklift truck, two wooden blocks (A) must be placed beneath the kiln so as not to damage the protruding lower edge of the surrounding outer metal sheet during transport. These must be at least as high as the bottom reinforcement strut (B) to prevent the kiln from tipping over. **Important:** The wooden blocks must not protrude outside the outer metal sheet.



3.2 Constructional and Connection Requirements

	<p>Notice Before starting the kiln for the first time, allow it to acclimatize at its installation location for 24 hours.</p>
	<p style="text-align: center;">⚠ DANGER</p> <p>Risk of fire, danger to health. If the installation recommendations are ignored, materials in the surroundings may catch fire.</p>

3.3 Installation Location

When installing the kiln, observe the following safety instructions:

Install the kiln in a dry place protected from the weather. If this is not observed, the housing can corrode and the electrical equipment may be damaged. Salty air accelerates this type of damage.

Kilns can radiate a lot of heat. Ensure a 40-inches (100 cm) gap (S) between the sides and top of the kiln and flammable and temperature-sensitive objects. The floor must not be made from flammable material. All flammable materials, such as drapes, plastics, furniture, rugs, etc., must be removed from the area around the kiln.

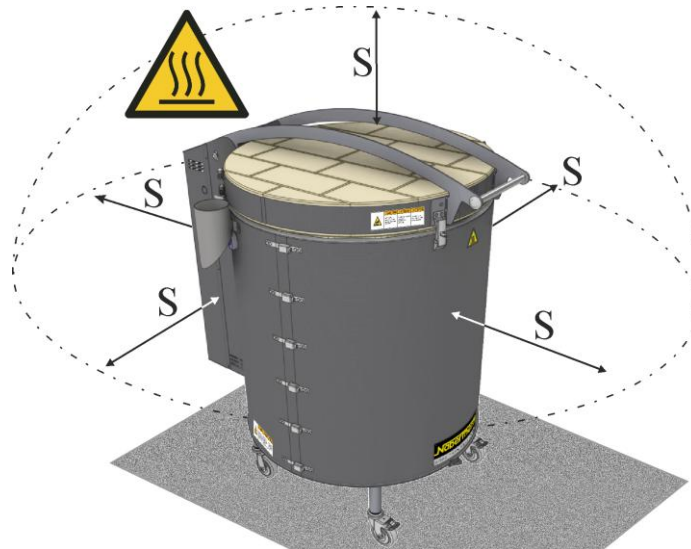

	<p style="text-align: center;">⚠ CAUTION</p> <p>Do not place the kiln closer to a wall made of flammable materials than specified below: Sides 40 inches (100 centimeters) Rear 40 inches (100 centimeters)</p>
---	--

The floor must have an adequate load-bearing capacity and must be level so that the kiln has a secure footing.

Access to the kiln must be restricted if the installation location can be accessed by unauthorized persons, children or pets.

If several kilns are installed in one room, make sure that the controllers and switchgears do not face neighboring kilns. Radiated heat from neighboring kilns can damage the controls.

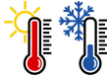

Keep temperatures between +41 °F (+5 °C) and +104 °F (+40 °C) and maximum humidity 80% non-condensing.

- The furnace must not be operated at locations above 2000 meters (6560 ft) above sea level

Ventilation

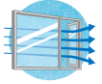

To ensure a healthy working environment and appropriate room temperature, the work room must be well ventilated.

Harmful vapors must be directed from the work room outdoors via professionally installed exhaust air piping.

In small rooms, especially if several kilns are installed in one room, make sure that the room temperature does not exceed 104 °F (40 °C).

Sprinkler system



If an automatic extinguishing system is installed at the kiln installation location, ensure that it cannot be activated by the radiated heat. In this regard, also consider whether to open the kiln while it is hot. Observe local construction and fire prevention regulations.

Fire prevention regulations







Local fire prevention regulations take precedence over the information in these operating instructions.

If you are not sure which regulations apply regarding the installation of a kiln, ask your local building inspector or your insurance company.

It must be ensured that the electrician who connects the kiln observes all local fire prevention and safety regulations.

Removing the transportation protection

	<p style="text-align: center;">⚠ CAUTION</p> <p>The kiln is heavy. You could injure your back. Have several people place the kiln on the frame.</p>	
	<p style="text-align: center;">⚠ CAUTION</p> <p>There is a risk of cutting injuries to the hand at the bottom edge of the housing. Wear cut-resistant gloves.</p>	
	<p style="text-align: center;">NOTICE</p> <p>Do not tip kilns on their feet. There is a risk that the housing could be damaged. To insert the castors and the frame extension, we recommend that you place the kiln on four suitable wooden blocks.</p>	

Installing the castors

The castors that are delivered can be attached to the kiln feet. We recommend to attach the castors with locking brake to the front of the kiln. Lift the kiln only from the bottom, not on the housing shell. The kiln must not be laid on its side.

1. At least two people are needed to lift the kiln; more people are needed for heavier kilns.
2. To attach the castors, we recommend that you place the kiln on four suitable wooden blocks.
3. These blocks (A) should be at least 15 inches (38 cm) high, so that the castors can be screwed beneath the feet.



A = at least 15 inches (38 cm)

4. The supplied castors can now be inserted under the kiln feet.
5. Lift the kiln and remove the wooden blocks. The kiln now sits securely on the castors and can be pushed to its installation location.
6. When the kiln is in position, lock the brakes on the castors.

Assembling the frame extension for top loader model Top 60 (accessory)

1. Remove the frame extension from its packaging.
2. To assemble the frame extension (3), we recommend that you place the kiln on four suitable wooden blocks. The wooden blocks should be at least 15 inches (38 cm) high
3. At least two people are needed to lift the kiln; more people are needed for heavier kilns.

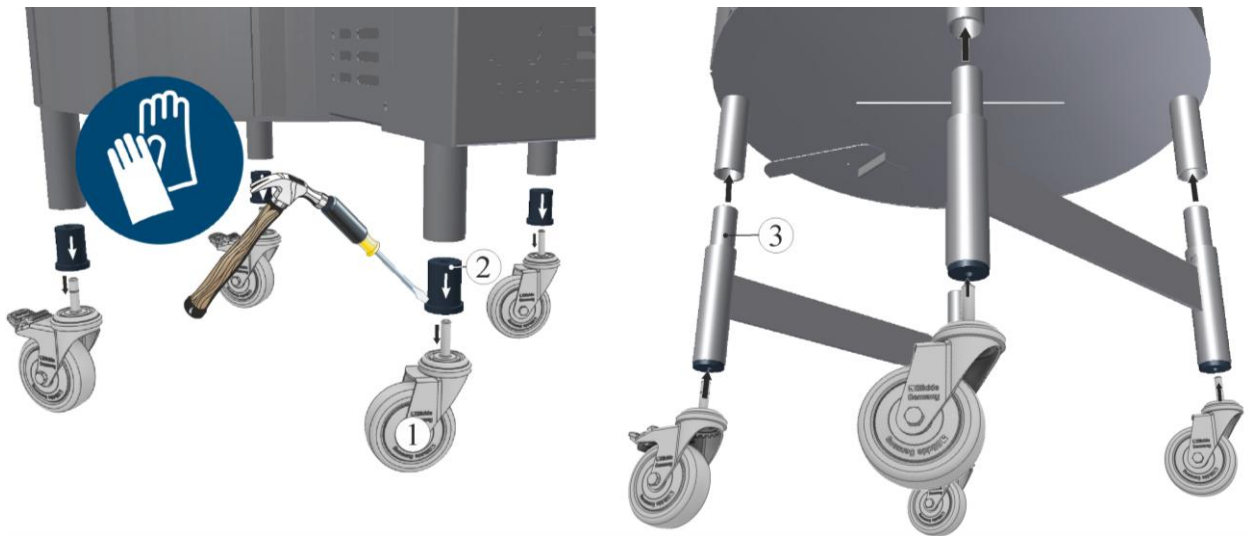

Assembling the raised base

4. To remove the castors (1), pull them firmly downwards.
5. Carefully loosen the sleeves (2) (on the kiln feet) with a wide screwdriver and hammer, for example.
6. The removed castors can be attached to the frame extension (3).
7. Carefully lower the kiln on to the frame extension (4). Make sure that the frame extension sits firmly. At least two people are required to lift the kiln.

Installing the controller

Attach the supplied controller with holder to the kiln.

1. At the controller position, there are screws (1) on the kiln to attach the holder; these must be unscrewed beforehand.
2. Place the controller holder (2) with the screws on the correct position on the kiln and fasten it with a suitable tool (3).

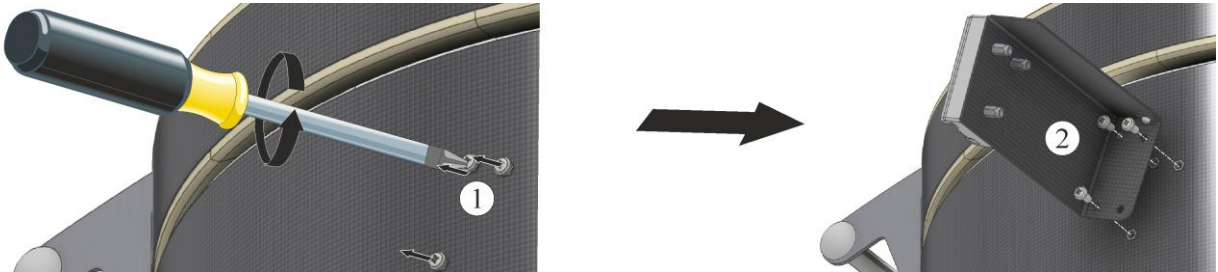

3. Tighten the screws (3) of the holder and check that it sits properly (4).

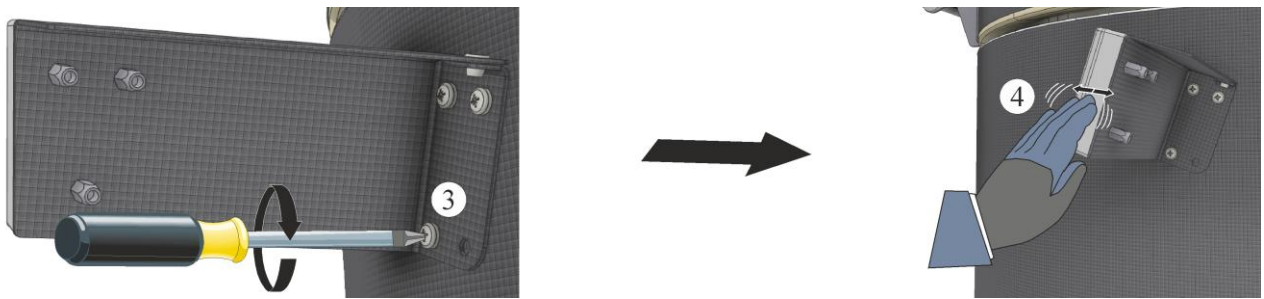

4. Place the controller in the holder on the kiln.

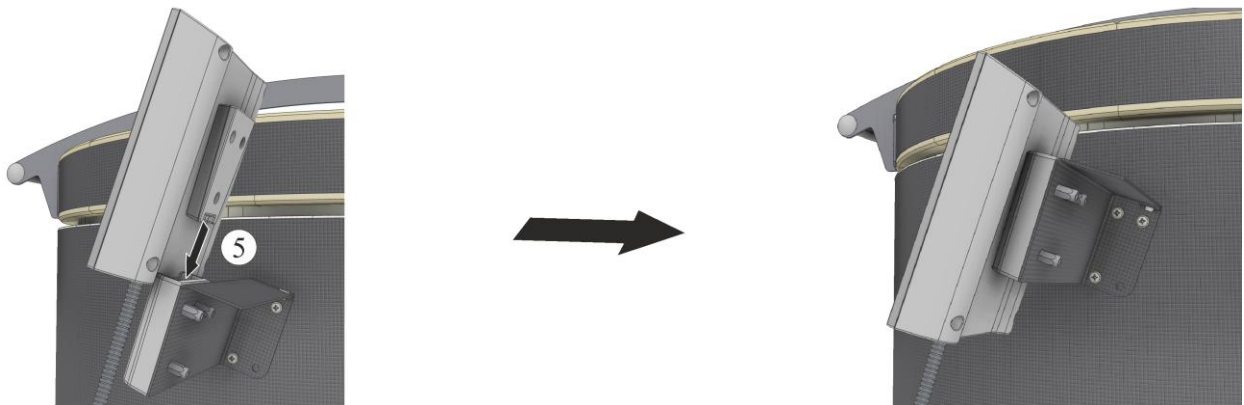

5. Place the controller in the holder on the kiln. Make sure that the controller is placed correctly in the holder.



6. The controller can simply be removed from the holder for ergonomic handling.

	<p style="text-align: center;">NOTICE</p> <p>Attached parts, such as a controller, must NOT be placed in direct sunlight or on hot surfaces. Damage/failure of the device Choose a suitable place to install the kiln</p>
--	--

Installing the exhaust air connection

The exhaust air connection that is part of the delivery is fixed to the side of the kiln.

1. The bracket on the exhaust air connection can be adjusted by bending it to suit the radius of the respective kiln model.
2. The bracket can be bent carefully with a suitable tool (e.g. pliers) at slits (A) and (B) until the bracket fits the shape of the kiln housing.

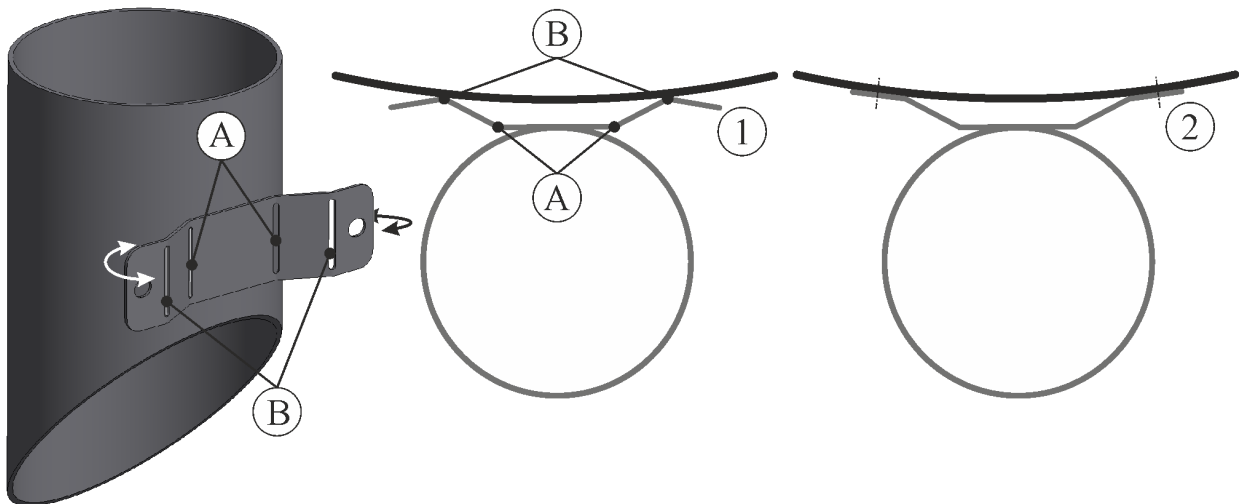

3. At the position where the exhaust air connection is installed, there are two screws (1) which must be undone beforehand.
4. Place the exhaust air connection (2) with the screws at the correct position on the side of the kiln and fasten with a suitable tool.

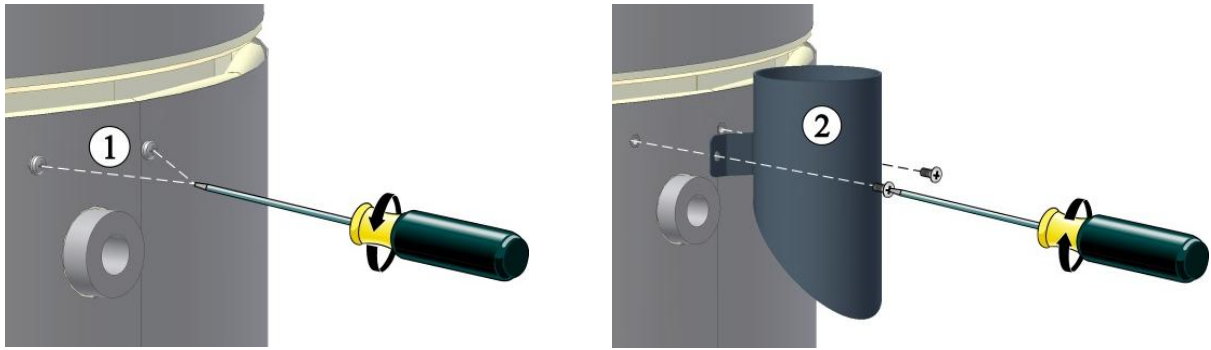

- When the bypass connection has been attached to and aligned on the kiln, a suitable exhaust air system should be installed.

Exhaust air System

SAFETY INFORMATION

Harmful vapors must be directed from the workroom outdoors via exhaust air piping. Contact a specialist company for correct installation.

For the exhaust air system, customer-side masonry and roofing work is necessary. The size and design of the exhaust air system must be defined by a specialist company. It must be ensured that the electrician who connects the kiln observes all local fire prevention and safety regulations.

When ceramics are fired, depending on the quality of the clay and/or glaze, they can emit gases and vapors that are harmful to health. It is therefore necessary to make sure that the “exhaust air” emitted from the exhaust air opening is directed outdoors in a suitable manner and that the location is well ventilated. If adequate ventilation cannot be ensured at the installation location, the “exhaust air” must be removed specifically via a pipe.

The heat occurring during firing may make additional room ventilation necessary depending on the room size and conditions of the installation location. 1/3 of the heating capacity of the respective kiln can be used as a guide for dimensioning the room ventilation.

If the kiln is installed in a “passive house”, it must be ensured that the room has an adequate fresh-air supply. Because of potential aggressive vapors, we do not recommend connecting it to the house ventilation system. We recommend a separate kiln room that can be ventilated adequately.

The exhaust air pipe must be fitted to the exhaust air connection starting with a rising bend so that the cover can be opened easily.

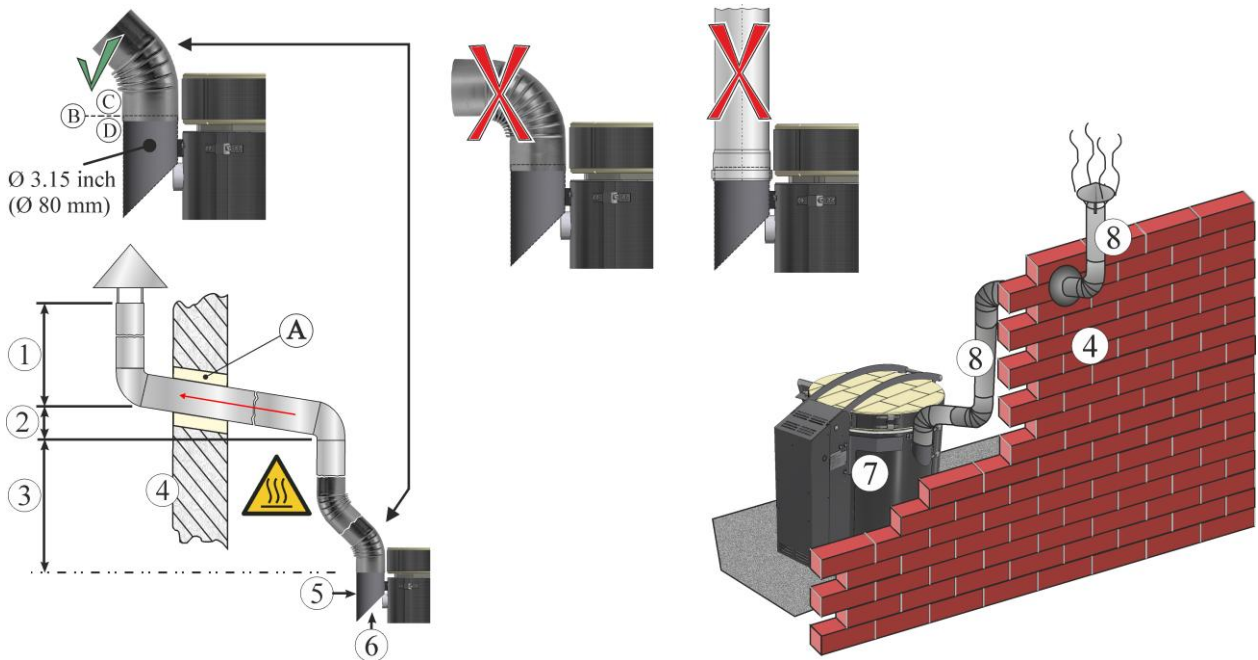



1	min. 20 inches (50 cm)	2	Install pipe in an upward direction (approx. 7°)
3	min. 40 inches (100 cm)	4	Outside wall
5	Bypass connection	6	Bypass effect
7	Kiln	8	Exhaust air piping
A	Wall duct	B	Supply limit
C	Customer	D	Bypass connection

SAFETY INFORMATION

Active ventilation of the installation room must not cause underpressure in the room, as this would affect extraction of the exhaust air from the room via the exhaust-air connection.

3.4 Connecting the Kiln to the Power Supply

	⚠ DANGER
	<p>Working with electrical equipment can cause serious injuries or death. Danger from electric current. Work on the power supply and kiln may be carried out only by a licensed electrician.</p>
	NOTICE
	<p>Notice: connected to wrong voltage. Damage to the device. Check voltage before connecting and initial start-up and compare the voltage with the details on the type plate.</p>

Nabertherm GmbH Industriestraße 10/12, 73446 Heilbronn, Germany Tel: +49 (0)7141 1221-1 Fax: +49 (0)7141 1221-120 contact@nabertherm.de	Name: _____ Address: _____ City: _____
---	--



	<p>Notice</p> <p>The regulations applicable in the country where the equipment is installed must be observed.</p>
---	--

It must be ensured that the electrician who connects the kiln observes all local fire prevention and safety regulations. In the US, electrical installations must be carried out in accordance with the National Electrical Code (NEC) and in Canada according to the Canadian Electrical Code (CEC).

These codes define specific requirements for the installation and operation of electrical equipment. These regulations are intended to ensure the safety and reliability of electrical systems.

Kilns with a high current are delivered without a plug and must be hard-wired to a connection box with circuit breaker. Section 2.2. “Specifications” contains an overview of electrical connections and plugs for the individual models (Electrical Overview). Special attention must be paid that the correct type of plug is used. It must be suitable for the prepared socket.

With fixed connections and wall sockets, make sure that the ground wire is connected correctly. If it is not connected correctly or if the wall socket does not have a ground wire connection, there is a risk of electric shock.

	 CAUTION
	<p>To ensure permanent protection against electric shock, use only a properly grounded socket.</p>

The power cable cross-sections to be used are described in “Specifications”. We recommend the use of copper wire power cables. The insulation must be suitable for temperatures $\geq 167\text{ °F}$ (75 °C).

Kiln with plug

Insert the plug into a suitable socket. Pay attention to the information on the type plate as regards voltage, supply type and max. power consumption. Do not use extension cables or power strips.

The distance between the kiln and the socket should be as short as possible, which is why extension cables may not be used.

The plug (kilns with plug) connects/disconnects the kiln and switchgear to/from the power supply. The plug must be easy to reach while the kiln is operating so that it can be removed quickly in case of an emergency (see “What to Do in an Emergency”).

The customer must ensure that the floor has adequate load-bearing capacity and that the necessary energy (electricity) is provided.

Hard-wired kiln (without plug)

Kilns that are hard-wired must have a circuit breaker visible from the kiln which disconnects the kiln from the power supply. This can be implemented by hard-wiring the kiln with a connection box with circuit breaker or by installing the kiln in an area with a line of sight to the fuse box.

The wire cross-section from the fuse box or connection box to the kiln must be adequate to carry the current of the kiln over a certain distance even in continuous operation and to reduce the voltage drop (see “Specifications”). If the wire cross-section is increased, this loss is reduced.



Model	Electrical connection	Screw connection	Clamping range	Hose
			in mm	in inches
Top 160	208 V 2/PE	M40	22.0 – 32.0	1-1/4"
Top 190	208 V 2/PE	M32	16.0 – 24.7	1.
	240 V 2/PE			
Top 190/R	208 V 2/PE	M40	22.0 – 32.0	1-1/4"
	240 V 2/PE			
Top 220	208 V 2/PE	M40	22.0 – 32.0	1-1/4"
	240 V 2/PE	M32	16.0 – 24.7	1.
	240 V 3/PE			

Kilns with a fixed connection have a preinstalled cable-hose fitting to hold the power cable and an optional protective hose. Assembly may differ depending on the kiln model and the screw connection that is used.

Overview of the individual parts of the screw connection for the power supply:



Power supply without conduit:

Strip the end of the cable. The ground wire must be slightly longer than the other wires.

Pull the screw connection and the plastic ring over the stripped cable.

Feed the wire into the screw connection.



Tighten the strain relief by tightening the nut over the rubber grommet.
Hold the screw connection with a second pair of pliers.



Check tightness by tightening all nuts, retighten loose nuts if necessary.



Power supply with conduit:

Pull the screw connection and the plastic ring over the conduit.



Screw the conduit fitting into the conduit by turning it.

Strip the end of the cable. The ground wire must be slightly longer than the other wires.



Feed the wire into the screw connection.



<p>Tighten the strain relief by tightening the nut over the rubber grommet. Hold the screw connection with a second pair of pliers.</p>	
<p>Check tightness by tightening all nuts, retighten loose nuts if necessary.</p>	

3.5 Initial Start-Up

Read the section on “Safety”. When using the kiln for the first time, it is very important that you pay attention to the following safety instructions.

Make sure that the instructions and information in the operating manual and the controller instructions are observed and followed.

Before starting the kiln for the first time, make sure that all tools, parts that do not belong in the kiln and transportation securing equipment have been removed from the kiln.

Before you switch on the kiln, make sure that you know what to do in case of faults or emergencies.

Before switching the kiln on for the first time, allow it to stand unpacked at its installation location for 24 hours.

Recommendations for heating the kiln for the first time

Heat the kiln without a charge to dry out the insulation and to get a protective oxide coating on the heating elements. The life of the heating elements is dependent on obtaining a good oxide coating. There may be some unpleasant odors while the kiln is heating. Ventilate the installation location of the kiln well during the first heating phase.

1. Fully open the fresh-air flap.
2. Close the lid and secure it with the lid lock
3. Switch on the kiln/controller at the power switch
4. Use “FIRST FIRING Program 01” from the pre-set programs the first time you heat up the kiln.
5. After the heating phase, allow the kiln to cool naturally.
6. Read the controller instructions for how to enter temperatures and times.

The insulation materials and furniture have natural residual moisture. During the first firings, condensation may accumulate and drip from the housing.

Program 01				
FIRST FIRING				
Segment	Start	Target	Time	Fresh-air flap ¹
1	32 °F (0 °C)	932 °F (500 °C)	360 min	Open manually
2	932 °F (500 °C)	1742 °F (950 °C)	180 min	
3	1742 °F (950 °C)	1742 °F (950 °C)	240 min	-

Program 01

FIRST FIRING

Segment	Start	Target	Time	Fresh-air flap ¹
4	Keep the lid closed until the kiln has cooled completely.			

¹ Fresh-air flap is opened manually.

3.6 Information about the Insulation

The kiln insulation is made from high-grade refractory material. Due to thermal expansion and material shrinkage, cracks will appear in the insulation after a few heating cycles. These have no influence on the function, safety or quality of the kiln.

Due to the manufacturing process of the insulation material, small holes or cavities may appear. These are quite normal and underline the quality features of the bricks.

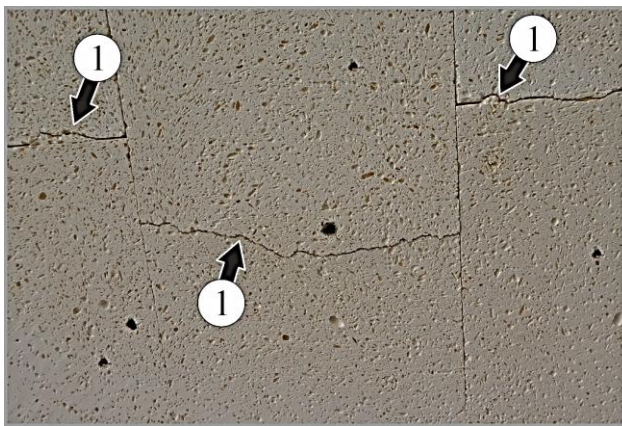

Cracks (1)

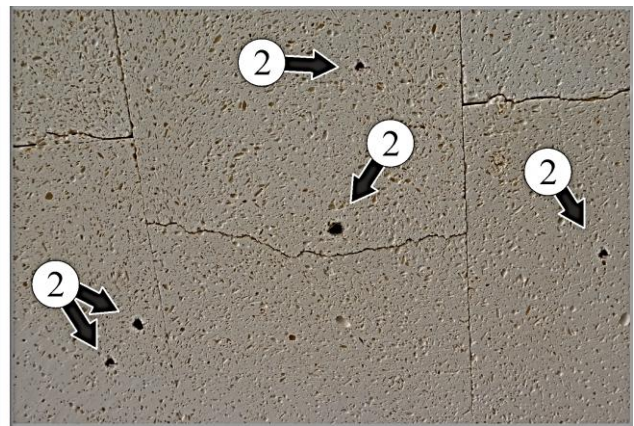

Holes (2)



Notice

New kiln furniture (e.g. shelves and props) should be heated once to dry them out (as described above). Heating elements are very brittle. Take great care when filling, emptying and cleaning the kiln.



Notice

At high firing temperatures, a sliver of light may become visible around the lid. This is normal and does not affect the kiln's function or safety.

4 Operation



	⚠ CAUTION	
	<p>Hot surface. Risk of burning. Do not touch the surface.</p>	
	⚠ CAUTION	
	<p>Do not open when hot Opening the kiln when it is hot above 390 °F (200 °C) can cause burns. Appropriate protective gloves must be worn.</p>	

1. Before switching the kiln on, check it. If there are external changes that could indicate a fault, the kiln must not be operated. If during operation, changes take place or the kiln makes strange noises, switch the kiln off for safety reasons.
2. It is important to take care when working with the kiln. During operation, areas on an around the kiln can become hot and cause burns if they are touched accidentally.
3. Check the tensioning straps on the lid regularly and retighten them with the screws on the side if necessary. More information can be found in “Servicing, Cleaning, and Maintenance”.
4. The lid must be completely open and secured before you load or unload the kiln. To do this, open the lid until it is secured by the locking bolt.
5. The kiln is not suitable for drying. Place only almost dry materials and furniture in the kiln. Objects with a high level of residual moisture can crack, split and cause corrosion on the kiln housing
6. Do not place flammable materials in the kiln. Remove, paper, wood and plastics. Materials that melt, produce flammable gases, explode or release harmful vapors must not be placed in the kiln.
7. For your safety and to protect the kiln and your ceramics, we recommend that you do not open the kiln until it has cooled down completely. Opening a hot kiln at temperatures above 390 °F (200 °C) will lead to increased wear of the insulation, heating elements and the kiln housing.
8. The lid can be secured with a lock. This is highly recommended if the installation location is accessible to unauthorized persons (such as children).
9. If the kiln has to be opened when it is still hot, you must wear suitable, heat-resistant protective clothing. Make sure that your clothing does not come into contact with hot surfaces. There is a risk that your clothing may catch fire or stick to the surface.
10. If a serious natural disaster is announced, such as storms, flooding or an earthquake, unplug the kiln or use the circuit breaker to disconnect the kiln from the power supply.



11. If a protective device is faulty (no switchgear cover, a faulty door contact switch, for example), do not switch the kiln on; instead, pull the plug or use the circuit breaker to disconnect the kiln from the power supply.

4.1 Controller



No.	Name
1	Display
2	USB interface

	<p>Notice</p> <p>For operation of the controller, please refer to the separate operating instructions.</p> <p>Watch the tutorials on our website.</p> <p>To access the operating instruction quickly, scan the QR code with your smartphone or enter the URL in your browser:</p> <p>www.nabertherm.com/en/downloads/video-tutorials</p> <p>Apps to scan QR codes can be downloaded from the corresponding sources (app stores).</p>
---	--

Switching the controller/kiln on		
Switch on the power switch		Set power switch to “I”. The switch is located on the rear of the kiln.
The kiln status is displayed. After a few seconds, the temperature is displayed.		Once the temperature is shown on the controller, the controller is ready for operation.
Switching the controller/kiln off		
Switch off the power switch		Switch the power switch to the “O” position. The switch is located on the rear of the kiln.





Using the controller

The controller can simply be removed from the holder for especially ergonomic handling and more comfortable operation.

After use, replace the controller in its holder.

Make sure that the controller is placed correctly in the holder during operation. If this is ignored, the controller may be damaged or destroyed. Nabertherm accepts no liability if the controller is not handled properly.

4.2 Opening and Closing the Lid

	⚠ CAUTION	
	<p>For your safety and to protect the kiln and your ceramics, we recommend that you do not open the kiln until it has cooled down completely.</p> <p>There is a risk of burning.</p> <p>Opening a hot kiln at temperatures above 392 °F (200 °C) will lead to increased wear of the insulation, heating elements and the kiln housing.</p>	
	<td data-bbox="1131 815 1331 1046" style="text-align: center;">  </td>	
	⚠ CAUTION	
	<p>If the lid has to be opened and the kiln has not completely cooled down, wear heat-resistant gloves to protect your hands.</p> <p>Make sure that your clothing is not close to kiln openings and does not touch hot surfaces, as there is a risk that your clothing could catch fire.</p>	

Operation and function of the lid catch

The lid securing mechanism ensures that it cannot close accidentally. The kiln operator must make sure that the lid catch engages audibly. The lid catch is located next to the switchgear.

SAFETY INFORMATION	
<p>The lid must be completely open and secured before you load or unload the kiln. To do this, open the lid until it is secured by the locking bolt.</p>	

1. When the lid is closed (1a), the lid catch is in the “waiting position”. The lever (1b) of the locking bolt is horizontal (see figure below).

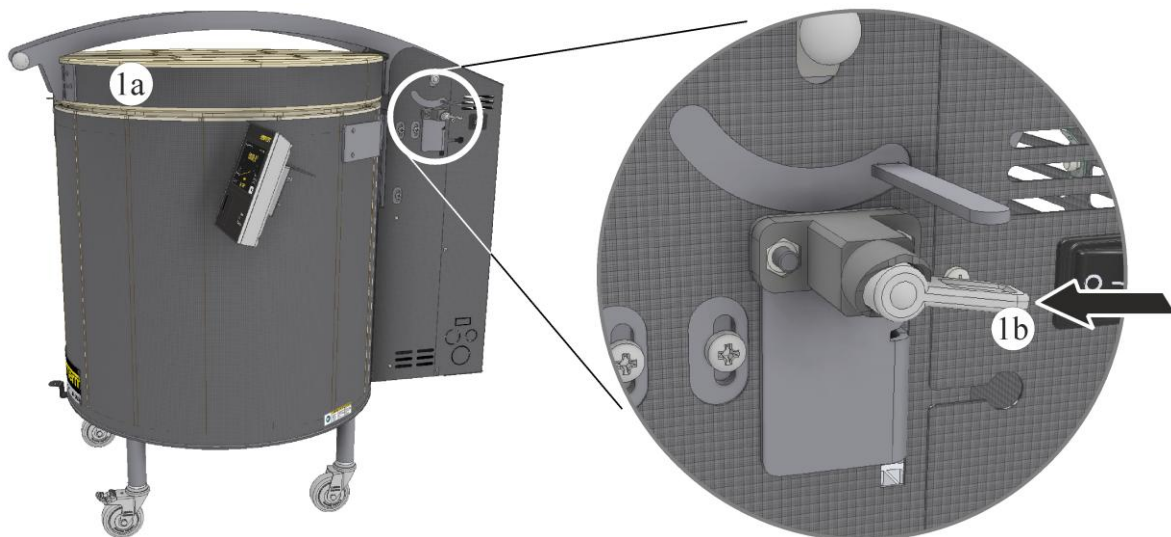

- Secure the lid: The lid must be completely opened (2a). The catch engages on its own and the lever moves downwards (2b). The lid must be secured before any repairs, cleaning or maintenance is carried out and before you load or unload the kiln (2c).

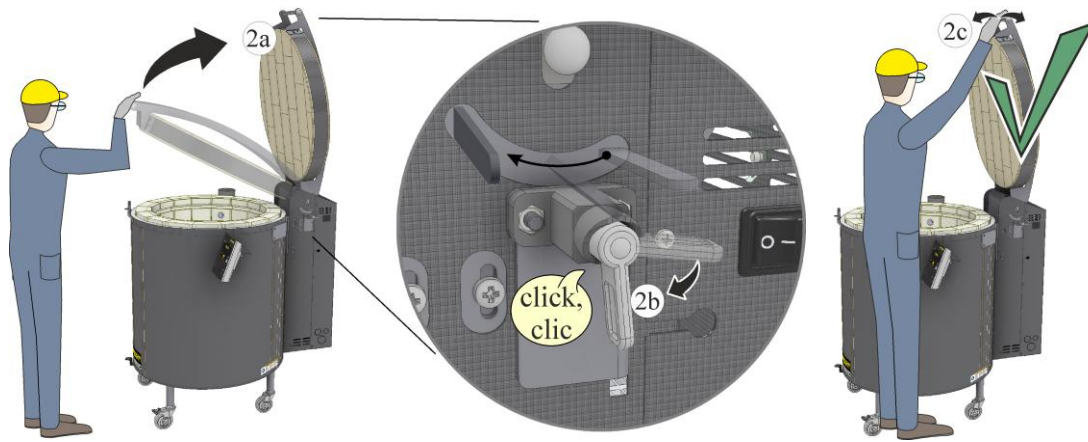

- Unlock the lid to close it: To close the lid, the catch has to be unlocked manually. Turn the lever (3a) of the locking bolt counterclockwise fully upwards by hand (3b). The lid catch has been unlocked and the lid can now be closed slowly.

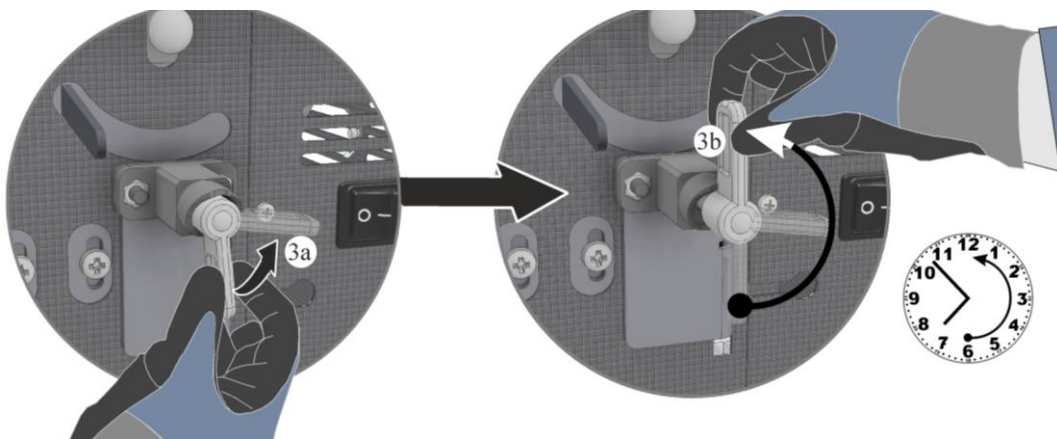

Opening the lid

The lid must be completely open and secured before you load or unload the kiln. To do this, open the lid until it is audibly secured by the locking bolt at the back of the kiln.

Open the lid catch as shown in the figure below. Pull the handle lightly to open the lid. The lid must be completely open before the catch engages audibly.

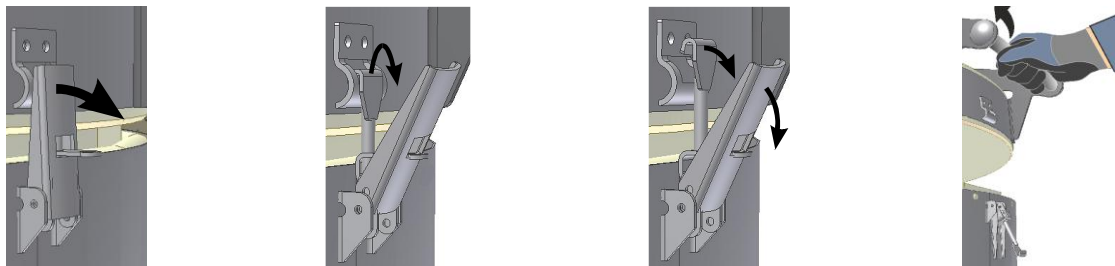

	<p>Notice At high firing temperatures, a sliver of light may become visible around the lid. This is normal and does not affect the kiln's function or safety.</p>
---	---

Closing the lid

Unlock the lid catch. Close the lid of the kiln carefully (don't slam it shut). Close the lid fastener as shown below. When the lid is closed, make sure that it is closed evenly all round. Check the lid fastener(s) and, if necessary, adjust the snap lock (A) by turning it so that the fastener can be closed without too much effort. If the locking mechanism is too tight, it is possible that a piece of insulating brick can break off.

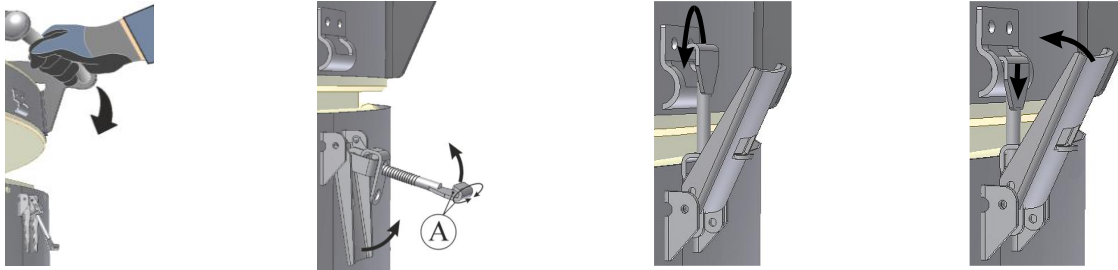

Access to the kiln must be restricted by the use of a padlock if it is possible that unauthorized persons, such as children, could gain access to it.



4.3 Fresh-Air Flap

The volume of air fed to the kiln can be adjusted with the fresh-air flap. When the fresh-air flap is open, a draft is created during firing to remove chemically bound water from the ceramics upwards. After the evaporation phase, close the fresh-air flap again to improve temperature uniformity at higher firing temperatures.

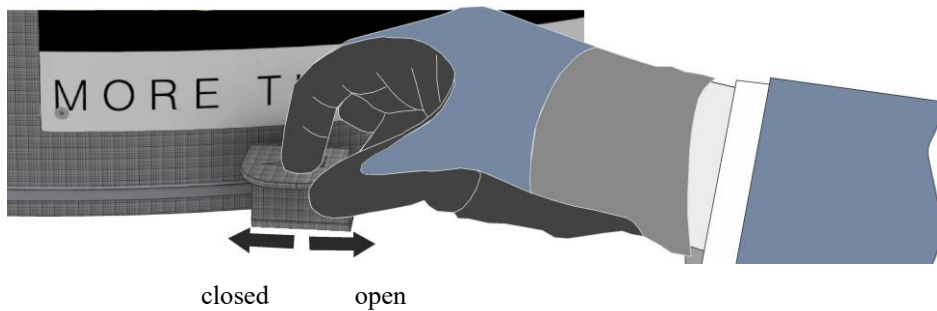

4.4 Loading/Charging



In areas where work is carried out, such as pottery making or operating the kiln, we recommend that you wear a suitable protective apron. This apron protects your clothing and also prevents burns.

SAFETY INFORMATION

The tension straps of the lid and kiln must be re-tightened regularly. Otherwise, there is a risk of damage to the edge of the lid (chipping) and deformation of the kiln housing. More details can be found in “Servicing, Cleaning, and Maintenance”.

Tension straps / lid tensioning ring

Note: Check position of tension straps / lid tensioning ring regularly and retighten as required. See “Adjusting the Tensioning Straps”.

We would like to point out that it is important that the operator does **not** lean against the housing when loading the kiln. If the straps are not tensioned enough, this could cause the kiln housing to deform.

Please also ensure that the lid strap is maintained sufficiently to prevent the insulation parts becoming loose and to avoid damage around the lid locks.

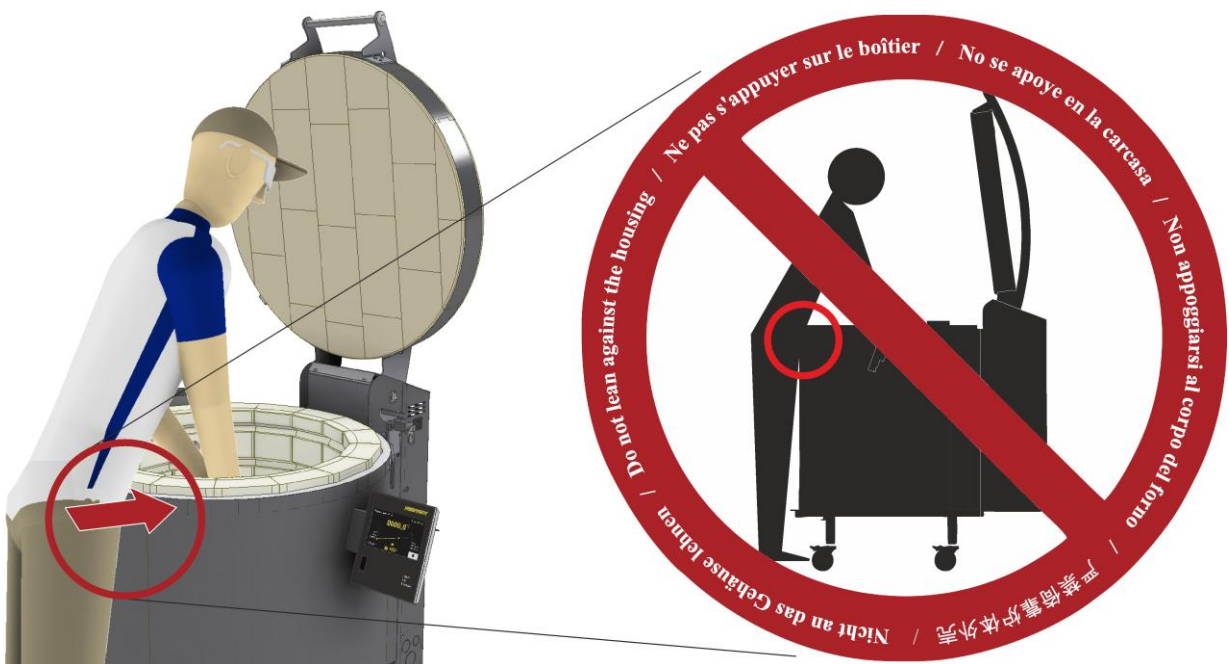

Do not lean against the housing

Loading the kiln

The delivery includes three tiles to distribute the weight on the kiln floor. The furniture is stacked on top of these tiles. To ensure stability, we recommend that these tiles are placed in a triangular arrangement.

Arranging the tiles and props (accessories)

Place three props in a triangular form on top of the delivered ceramic tiles. Place the ceramic tiles evenly on the floor of the kiln (A) beforehand.

The tiles must not cover the heating elements, but must be distributed so that they sit between the grooves to prevent heat build-up. This could damage or destroy the heating elements.

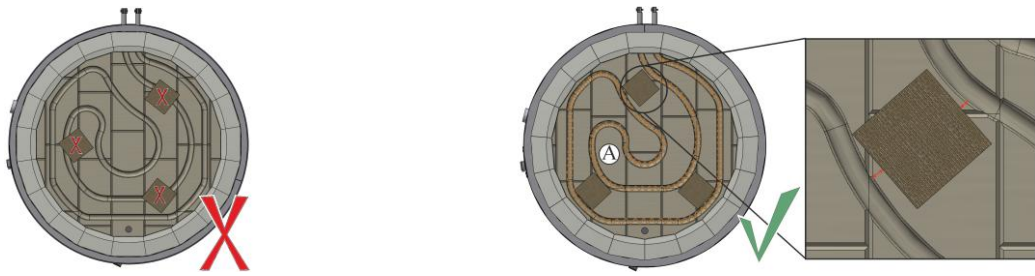

The distance (B) between the props depends on the size of the shelves and should be as large as possible to ensure stability.

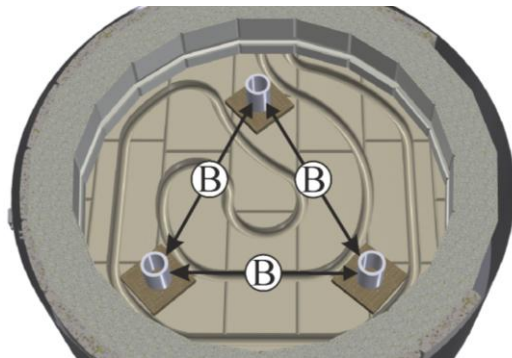

Place the shelf (C) on the middle of the props. **Never** place shelves directly on the floor of the kiln. Always use the supplied tiles and props to raise the first layer. Now place the ware that is to be fired in the kiln and distribute it as evenly as possible.

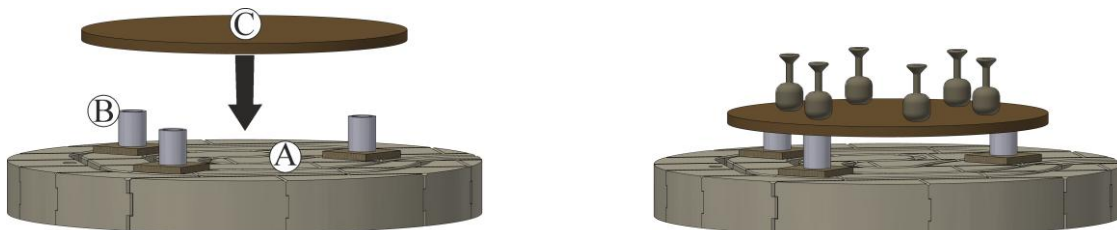

If a second level is required, place props on the bottom shelf to get the required distance between the shelves. These props should be situated exactly above each other, if possible, to ensure stability of the shelves.

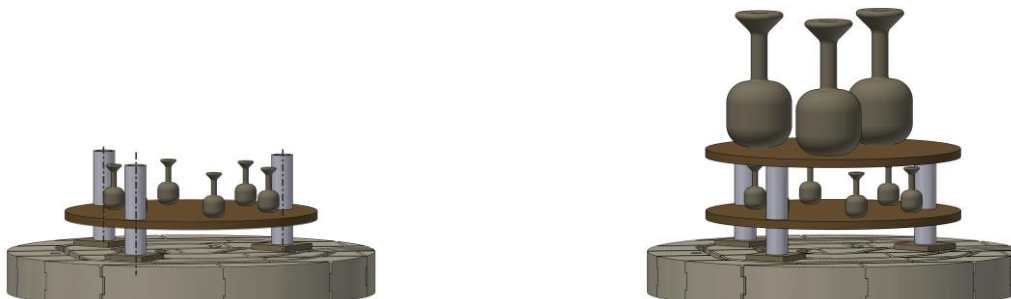

4.5 Operation of the Manual Zone Control from Model Top 160 Liters (Additional Equipment)

With the Nabertherm controller, you can control the floor heating as a second zone with top loader kilns from the Top 160 range and above. Set your firing curve on the controller as usual. If you realize that the power ratio has to be changed from top to bottom, you simply adjust the ratio.

To adjust the zone control, refer to the controller instructions, “Manual Zone Control”.

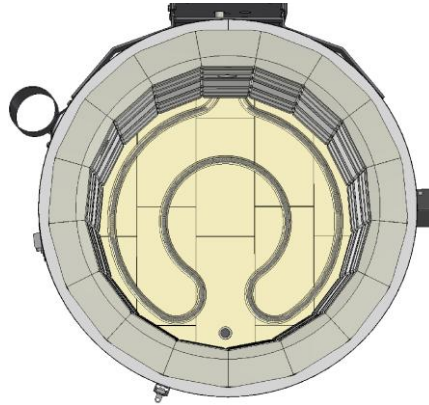

Additional equipment, floor heating

4.6 Potter Tips

	<p>Notice The temperature specifications given by clay and glaze producers must be observed.</p>
	<p>Notice Long-term operation at maximum temperature can lead to increased wear of the heating elements and insulation material. We recommend that you work to approximately 158 °F (70 °C) below the maximum temperature.</p>

So that the pottery that you have made with a lot of effort and passion is not destroyed, the following principles should be observed:

- Allow pottery to dry slowly – not in the kiln, the boiler room or in the sun.
- Dry pottery away from drafts – drafts cause uneven drying and drying cracks.
- Loosely cover projecting parts (e.g. handles) with paper or plastic film, as they dry faster than the rest of the pot. If you don't do this, cracks may occur at the joints.
- Clay shrinks when it dries; in other words, the volume is reduced due to the loss of water. Objects that stick to a surface, crack when they shrink – therefore, always place your pottery on fresh, clean surfaces.
- Turn your pottery often as the top dries quicker than the bottom.
- Handle dry pottery carefully with both hands and don't lift it by the edges. Pottery is very fragile in this state.
- Fire only completely dry objects in the kiln.

Bisque firing

When the green ware is completely dry, it is bisque fired; that is, it is fired in the kiln at approx. 1652 °F to 1742 °F (900 °C to 950 °C). The first firing – the only firing for unglazed pottery – changes the physical and chemical properties of the clay. It becomes hard and insoluble in water.

During bisque firing, the ceramic pieces in the kiln can touch each other. They can be stacked (also inside each other), as long as they are not too heavy and do not prevent each other shrinking. Tiles or flat plates should be placed directly on the shelves to prevent distortion. It really depends on the size of the objects whether they are stacked on several shelves or if a few larger pieces fill the entire kiln. However, the kiln chamber should not be “overloaded” or be packed too densely.

For the firing it is important that you know what happens to the pottery. It loses a lot of chemically bonded water and shrinks. If the kiln temperature is raised too quickly, the steam does not have enough time to escape and objects can crack and damage the kiln. Therefore, it is important to heat the kiln slowly. Nabertherm controllers handle this task fully automatically. From this time, you can heat the kiln to the final temperature at full power. During the evaporation phase, open the fresh-air flap of the kiln, as this creates a draft effect and the moisture is discharged upwards out of the kiln via the exhaust air connection. After the evaporation phase, close the fresh-air flap again to improve temperature uniformity at higher firing temperatures.

Because of the kiln’s large mass and good insulation, it takes several hours for the kiln to cool; be patient. You should open the lid a little only when the temperature in the kiln has fallen to about 392 °F (200 °C).

When you open the kiln, you will see that the bisque ware has shrunk. It makes a different sound when you touch it and the clay is a different color.

Glaze firing

Usually, glaze firing is the highest temperature firing. The temperature range for earthenware is 1868 °F to 2012 °F (1020 °C to 1100 °C). For a stoneware firing, the kiln must reach at least 2282 °F (1250 °C). The glazes must be adapted to suit the temperature range.

The top of the shelves should be painted with a separating agent before a glaze firing. This coating should be renewed from time to time.

Check the areas where the pottery is to stand – they must be free of glaze. Pottery with a glazed base must be placed on stilts or triangular rods for the firing. Glazed pottery should be handled very carefully and should not be touched at the edges. The pieces must not touch each other in the kiln, as the glazes would melt together. There must also be a gap of at least 1 inch to the heating elements. Unsintered glazes must not touch the heating elements.

Use only glazes in one melting range in a firing. For the firing, heat the kiln slowly (approx. 356 °F (180 °C) per hour) to about 932 °F (500 °C). Glaze water may escape during this phase. Then heat the kiln to the end temperature at full power. Hold this temperature for about 30 minutes so that the glaze melts evenly on the ceramics in all areas of the kiln. Only open the lid or door when the temperature has dropped below 122 °F (50 °C). Many glaze cracks are the result of opening the lid too soon.

You can grind any glaze drops on the bottom of the pottery or the shelves with a grinding stone or an angle grinder, paying attention to all the safety regulations.

Do not use very runny glazes to avoid damaging the shelves, the kiln insulation or the heating elements and the kiln itself.

Cooling

With a kiln, “natural cooling” is the process in which, after a firing process, the kiln cools slowly to room temperature without forced cooling (for example, opening the door) and without active heating.

Natural cooling ensures that the temperature is evenly distributed, which ensures the structural integrity of the ceramic and helps conserve the kiln furniture.

This process can take several hours or even days, depending on the size of the kiln, the weight of the charge and the density of the charge.



The rate of natural cooling varies. At high temperatures, the kiln cools quickly. As the temperature falls, the rate of cooling slows down.

Natural cooling is a universal recommendation that promises success with most applications.

For example, workpieces with thicker walls require much slower cooling rates than the natural cooling rate of the kiln. In these cases, cooling is accompanied by active heating.

5 Servicing, Cleaning, and Maintenance

5.1 Basic Measures

	⚠ DANGER Dangerous voltages can cause serious injuries or death. Disconnect the power supply before commencing maintenance work
	⚠ CAUTION Work on the electrical equipment may be carried out only by a licensed electrician.

The kiln must be cooled to room temperature. When maintenance or repair work has been completed, ensure the following before recommencing production:

- Check that loosened screw connections/tensioning straps have been retightened,
- Reinstall protective equipment, such as switchgear covers,
- Remove all materials, tools, and other equipment used for maintenance or repair work from the working area of the kiln,
- Remove processing residue in the switchgear, inside the kiln and on the heating elements.
- Power cables may be replaced only with similar, approved cables and by a licensed electrician.

5.2 Working on the Insulation

Repairs to the insulation or replacement of components inside the kiln must be carried out by persons who have been trained with regard to potential hazards and protective measures and who are able to apply this knowledge on their own.

	Notice When working on the insulation or when replacing components inside the kiln, observe the following: During repair or demolition work, silica dust may be released. Depending on the materials being heat-treated in the kiln, the insulation may contain other contamination. To exclude health hazards, keep dust to a minimum when working on the insulation.
---	---

Dust emissions should be kept to a minimum. Dust should be removed with extraction equipment or a vacuum cleaner with a high-performance filter (HEPA – category H). Swirling, for example due to drafts, must be prevented. Compressed air and brushes must not be used for cleaning. Moisten accumulations of dust.

If work is carried out on the insulation, breathing protection with FFP2 or FFP3 filters must be used. Work clothing should cover the whole body and sit loosely. Gloves and safety glasses must be worn. Before removing contaminated clothing, clean it with a vacuum cleaner with HEPA filter.

Avoid contact with skin and eyes. The effects of fibers on the skin or in the eyes can cause mechanical irritation, which can, in turn, lead to redness and itching. After work and after direct contact, wash skin with soap and water. If there is contact with the eyes, rinse the eyes thoroughly for several minutes. Consult an ophthalmologist if necessary.

When disposing of the materials, observe national and regional regulations. Possible contamination from the kiln processes must be taken into account.

5.3 Regular Maintenance of the Kiln

If regular maintenance work is not performed, all warranty and liability claims for personal injury and material damage are excluded.

Component/ item/ function and action	Comment	A	B	C
Lid switch (switches the heating off when the lid is opened) Function check	Located in the switchgear	3	Y	X1
Kiln chamber, extraction holes and extraction tubes Clean and check for damage, vacuum carefully			Q	X1
Heating elements Visual inspection		3	Q	X1
Thermocouple Visual inspection		3	Q	X1
Tension straps / lid tension ring Check position and tension, adjust if necessary		3	Q	X1
Lid locks Check setting and adjust if necessary		3	M	X1
Gas strut Check for sufficient counterforce and secure hold in the open position of the lid	Located in the switchgear	3	M	X1
Lid safety catch Check the function of the locking bolt / lubricate if stiff Clean safety catch beforehand		3	D	X1
Setting for fit of the lid (tight closure/fit of the lid) Check setting and adjust if necessary			Y	X1
Electrical fuses in the kiln (depends on the model)	Check in case of insufficient or no heating power	1		
Type plate Legible condition		3	Y	X1
Operating instructions Ensure they are kept near the kiln		3	Y	X1
A = Spare parts stock	1 = Stock urgently recommended 2 = Stock recommended 3 = As required, not relevant			
B = Maintenance interval	D = Daily, before each start of the kiln W = Weekly M = Monthly Q = Quarterly Y = Yearly			
C = Responsible	X1 = Operating personnel X2 = Specialist personnel			

Cleaning – vacuuming the kiln

SAFETY INFORMATION	
<p>Follow the procedure to switch off the kiln (see “Operation”). Pull out the plug or disconnect the kiln from the power supply via the circuit breaker (depends on the model)</p>	
	<p>Notice</p> <p>Use a vacuum cleaner with a HEPA filter to prevent dust getting into the surroundings.</p>

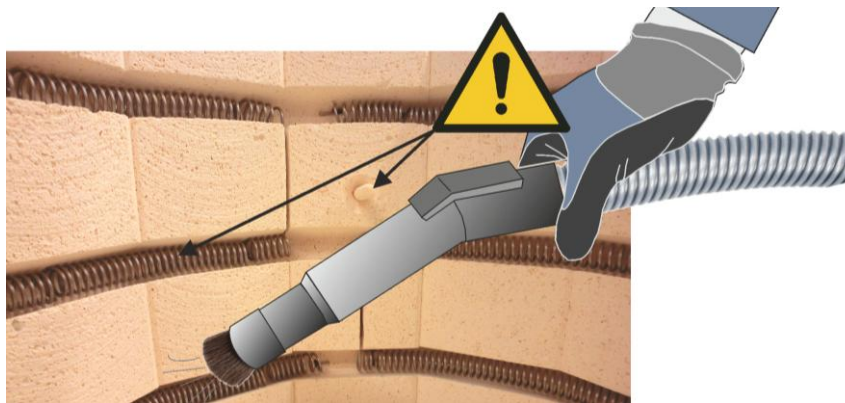

We recommend that you clean the kiln chamber and the insulation brick regularly and after repairs with a vacuum cleaner. Use the soft brush nozzle of the vacuum cleaner. Take care when vacuuming and avoid touching the heating elements and thermocouple with hard objects.

Deposits in the grooves and on the heating elements can considerably reduce the service life of the heating elements.



Metal and glass surfaces can be cleaned with a lint-free cloth. You may also use the following cleaning products:

Component and position	Cleaning product
Metal surface	Stainless steel cleaner
Instrument field on the controller	Wipe the surface with a damp, lint-free cloth. Do not use aggressive cleaning products.
Interior (pay attention to the heating elements and thermocouple)	Carefully clean with a vacuum cleaner

	NOTICE
	<p>The kiln, kiln chamber and attached components must NOT be cleaned with a high-pressure cleaner. Pouring water over the kiln or using a high-pressure cleaner will destroy the kiln.</p>
	CAUTION
	<p>Do not use water or other liquid cleaning products to clean the insulation. Cleaning with water or other liquid cleaning products will destroy the insulation.</p>

Adjusting the lid

If the lid no longer rests on the hinge side when it is cold (can be seen by a gap between the lid and the collar insulation), undo the screws (2) on both sides of the switchgear cover and press the cover onto the collar insulation. Before you make the adjustment, make sure that the lid is closed using the front lock (1).

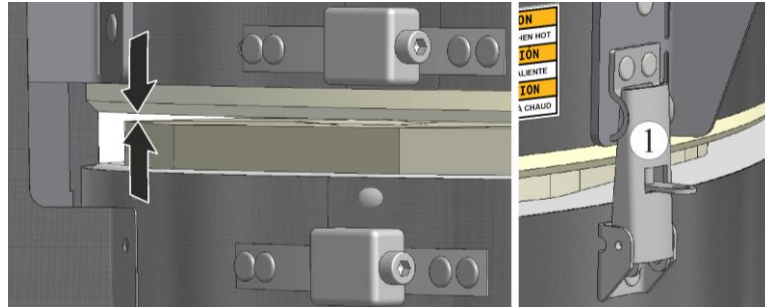

Secure the lid with the front lock

We recommend that two people adjust the lid.

1. To adjust the lid, undo the screws (2) on both sides of the switchgear cover (see picture “Screws to adjust the lid”) with a suitable tool.
2. Press the lid down on the hinge side until it sits evenly on the collar insulation.



Screws on both sides of the switchgear cover to adjust the lid

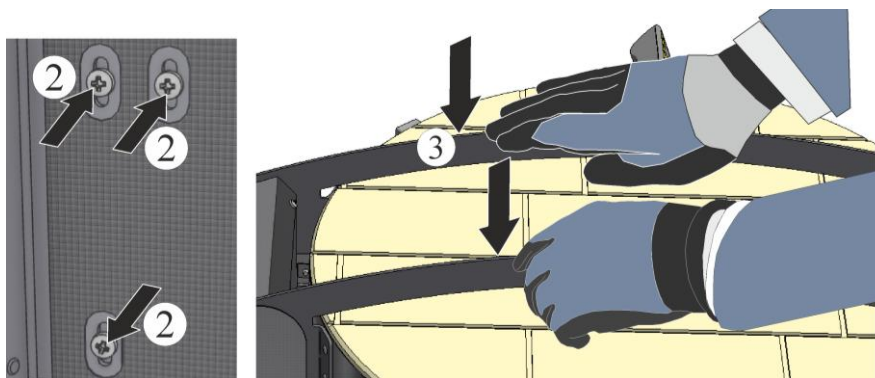

3. Have a second person hold the lid down. Retighten the screws (2) on both sides of the switchgear cover.
4. Make sure that the lid closes evenly all round; if not, realign the lid.

Adjusting the lid lock/gap between the lid and kiln collar

A gap between the kiln collar and the lid at high temperatures is normal and quite safe. Under normal circumstances, the lid lock does not have to be retightened in this case.

Under certain conditions it may be practical to adjust the lid lock. It should close the lid but not too tightly so that the insulation bricks are not damaged.

Before adjusting the lock, make sure that the lid sits properly on the collar all around. The tension strap of the lid must be tightly tensioned. A loose lid strap tends to slide down and deform and may damage the insulation when the lock is tightened.

Close the lid of the kiln carefully (do not slam it shut). Close the lid lock as shown below.

When the lid is closed, make sure that it is closed evenly all round. Check the lid lock(s) and, if necessary, adjust the snap lock (A) by turning it so that the lid lock can be closed **without** too much effort.

If the lock is adjusted too tightly, this can damage the lid (brick insulation).

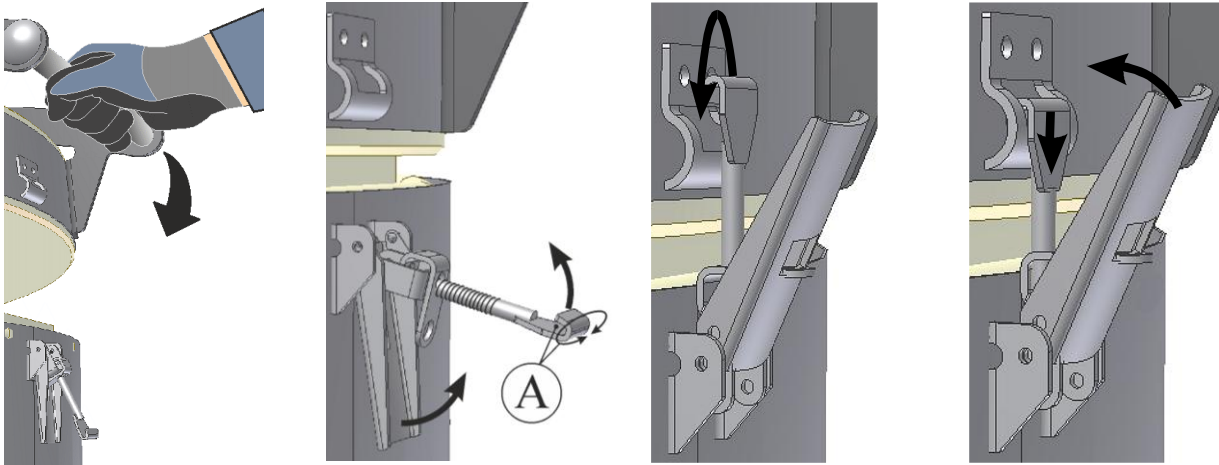

CAUTION

Risk of damage:

Please adjust the lock carefully. If the lock is adjusted too tightly, this can damage the lid.

Adjusting the tensioning straps

Insulation mats can become compressed through transportation and after use. This is a natural property. As a result, the tension of the lid strap and the shell around the insulation becomes looser, which has an effect on the mechanical stability of the insulation and the housing. It is therefore important to check regularly that the straps are in the correct position and to tighten the tension straps as required.

With a new kiln, this may be necessary at shorter intervals.

You can tell if the lid strap is not sufficiently tensioned if you can move parts of the insulation, if the lid strap has slipped down from the middle of the kiln lid and deforms when you close the lid lock.

1. Secure the tension strap mechanism with pliers before tensioning.
2. At the same time, retighten the respective tension strap by a maximum of a quarter turn using an Allen key. Be careful, as the tension straps can easily be overtightened.
3. Tighten the tension straps below one after the other, each by a maximum of a quarter turn.

Repeat the procedure (1-3), starting with the top strap.

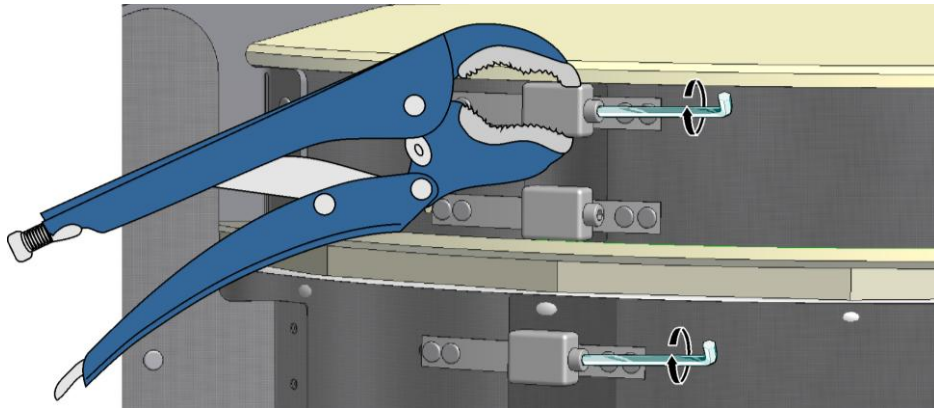

CAUTION

Risk of damage:
 Tighten tension straps carefully and just a little at a time

Lid locking mechanism

The ease of movement of the locking mechanism must be checked regularly.

1. Close the lid.
2. Turn the lever of the locking bolts counterclockwise fully upwards by hand.
3. Spread the lubricant around the bolt.
4. Use only a little lubricant and then move the bolt back and forth to ensure that the lubricant is spread evenly.
5. Then place the bolt by hand in the “waiting position”.

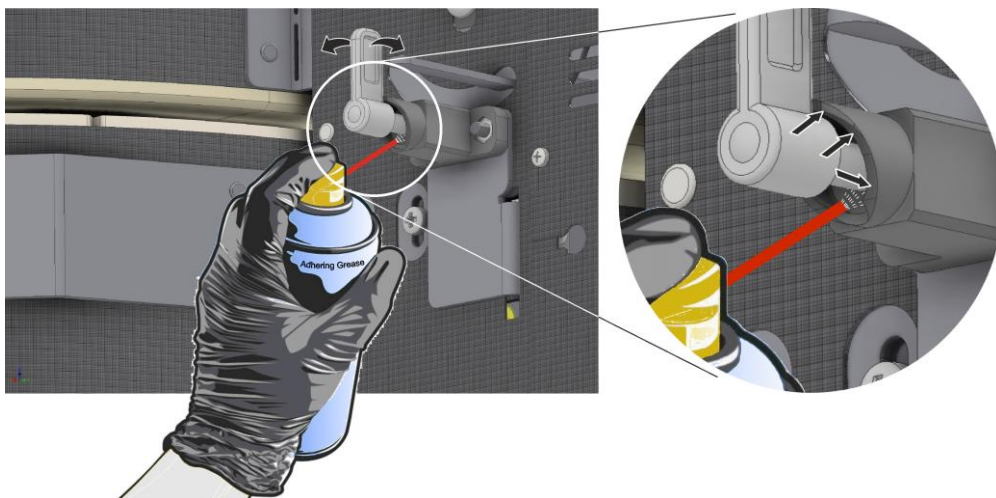

Checking the lid switch

The lid switch ensures that the heating switches off when the lid is opened. Proper functioning off the lid switch can be checked as follows:

1. Close the kiln lid
2. Start a program and wait 10 seconds
3. Raise the lid (max. 1.5 inches) until you hear a click from the switchgear
4. Close the lid and stop the program

If you do not hear a click, have a licensed electrician check and adjust the function. The kiln must not be used until the cause has been rectified.

When replacing or adjusting the lid contact switch, it is essential to precisely tighten the mounting fasteners to a torque of **2 Nm**. A lower or higher torque may cause the switch to malfunction.

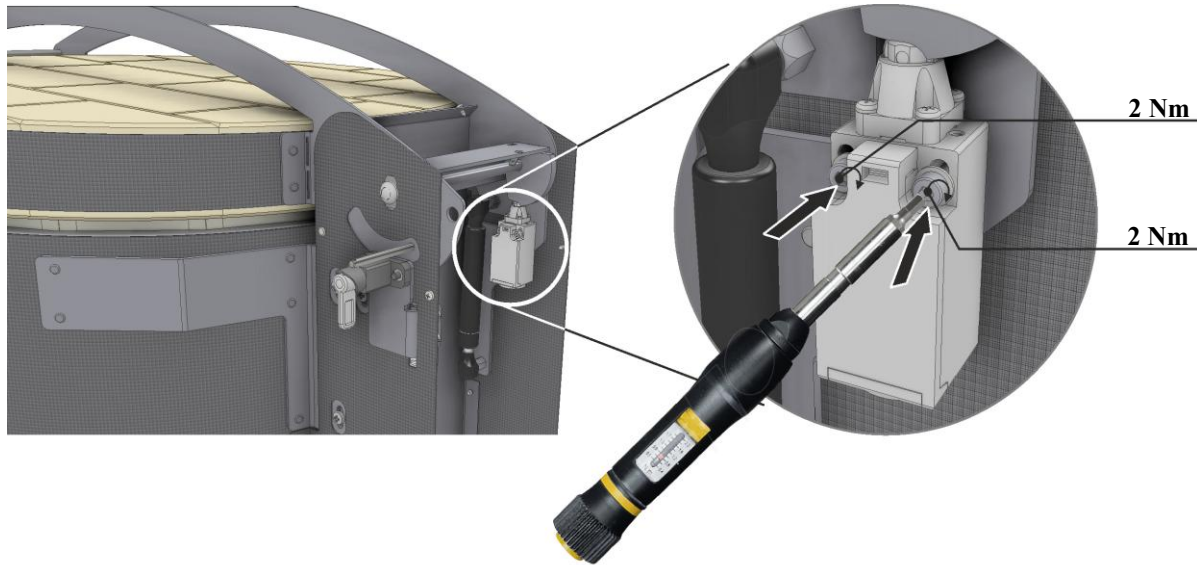



Checking the gas strut

The gas strut (two struts on larger kilns) supports opening and closing the lid. When the lid is difficult to move, especially when opening, this is an indication that the gas struts are in need of replacement.

The function of the gas struts can be checked as follows:

1. The kiln is cool and no program is running.
2. Open the lid fully until it is locked in place.
3. When the catch is released, the lid must remain open and must not lower on its own.
4. If the lid starts to lower on its own, the gas struts (one or two struts depending on the model) must be replaced. The kiln must not be operated until the gas struts have been replaced and the function of the lid is assured again. Replacing the gas strut is described in “Spare Parts/Wearing Parts”.

	 CAUTION
	<p>The kiln must not be operated with a faulty gas strut. A gas strut is faulty if the lid is difficult to open and the lid does not remain in the fully open position.</p>

6 Malfunctions

	Notice
	<p>Refer to the separate instruction manual for a description of the error messages of the controller and switchgear.</p>

Electrical work on kilns must be carried out by a licensed electrician. Operators may only rectify faults that are obviously due to operating errors.



7 Spare Parts/Wearing Parts

Ordering spare parts

Our Nabertherm Service team is available worldwide. Due to our high level of vertical integration, we supply most spare parts from stock. Nevertheless, it may be advisable to stock up on the most important spare and wearing parts.

	<p>Notice</p> <p>Original parts and accessories are designed specifically for Nabertherm kilns. Only Nabertherm original parts may be used when replacing components. Otherwise, the warranty will be void. Nabertherm accepts no liability for damage caused by using parts that are not original Nabertherm parts.</p>
---	---

7.1 Replacing the Heating Elements

	⚠ DANGER	
	<p>Work on the electrical equipment may be carried out only by a licensed electrician. Danger of electric shock. Pull out the plug or disconnect the kiln from the power supply via the circuit breaker (depends on the model)</p>	

	⚠ CAUTION
	<p>The pointed ends of the wires are a potential injury hazard. Cuts. Wear appropriate protective gloves.</p>

SAFETY INFORMATION
<p>Make sure that no cables are protruding or trapped. Pay attention to sharp surfaces. Tighten all screws on the connection terminals after one week of operation and then once each year. Avoid all stress or twisting of the heating wire. If this advice is not followed, the heating wire may be damaged.</p>

	<p>Caution – Damage to components!</p> <p>Heating elements are extremely fragile. Avoid all stress or twisting of the heating elements. If you do not follow this advice, you may damage the sensitive heating elements.</p>
---	---

	<p>Notice</p> <p>The pictures contained in the instruction manual may differ in terms of function, design and kiln model.</p>
---	--

1. Undo the screws (1) of the cover with a suitable tool and keep them in a safe place for future use.
2. Carefully fold back the switchgear cover (2 and 3).

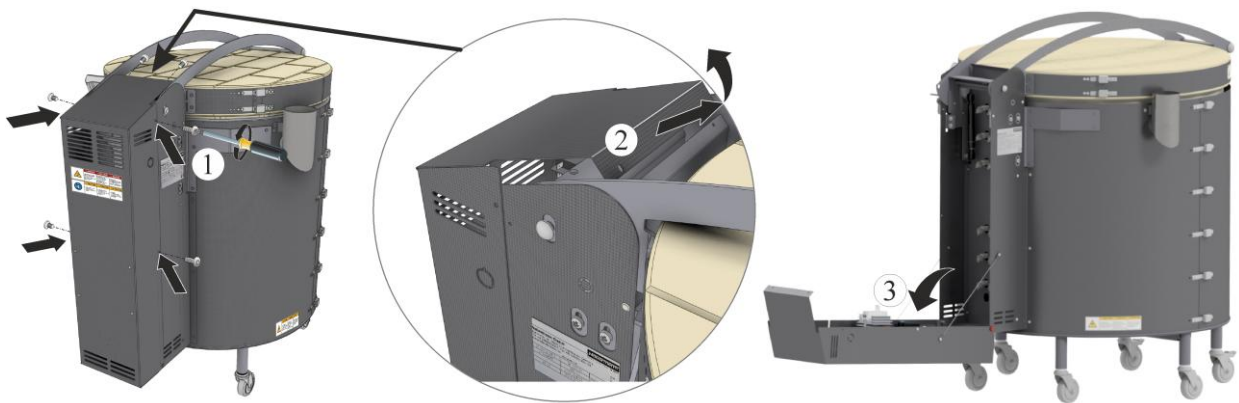

3. To replace the heating elements, open the lid of the kiln completely.
4. Undo the screws of the connection terminals. Place the screws and the connection terminal in a safe place so that they can be reused. So as not to damage the connection terminal or the ceramic feedthrough tube, we recommend the use of a suitable pipe wrench as a brace when unscrewing the screws of the connection terminal.

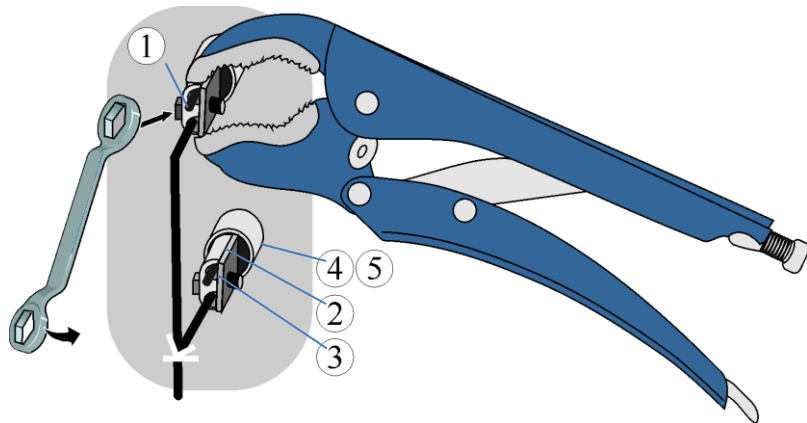

1 Hexagonal screw / 2 Terminal / 3 Heating element end / 4 Ceramic feedthrough tube / 5 Fiber wadding

5. Carefully remove the ceramic feedthrough tubes and put them in a safe place so that they can be reused. If they are cracked or have deposits on the inside, they must be replaced.
6. Carefully pull out the heating element ends (3) of the heating wire from inside the kiln.

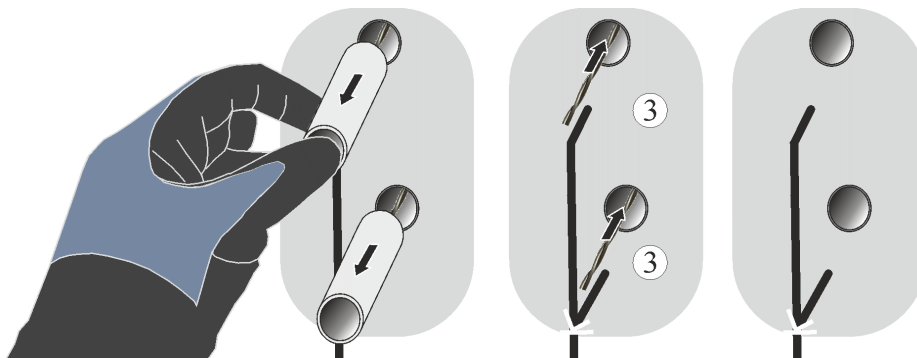

- Before you pull the heating wire out from inside and/or carefully and slowly unwind it, remove all fasteners (1) with long-nose pliers. When removing the heating wire, make sure that the grooves in the insulation brick are not damaged.

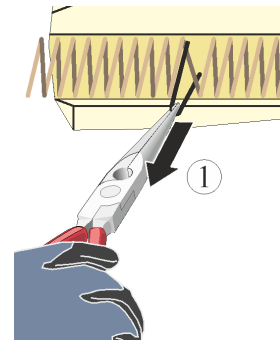
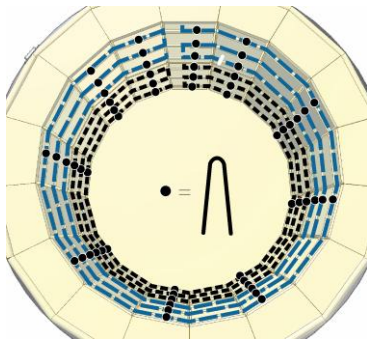

Installing the new heating elements

The (twisted) ends of the heating elements have a loop as protection. This has to be removed with a suitable tool before installation.

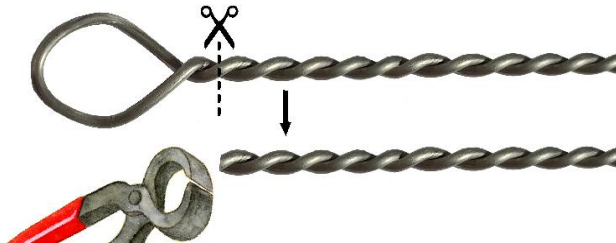

Check the supplied heating wires for damage before installation.

Shorten the heating wires as illustrated. The length and geometry depend on the kiln model and installation location.

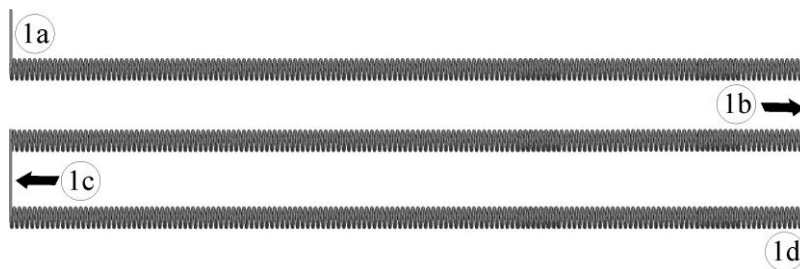

Procedure:

- First, insert the end of the heating element (1a) into the intended opening from inside (this is the opening that you pulled the previous heating element end out of).
- Now place the heating wire carefully into the grooves. Carefully press the heating wire connections (1b and 1c) into the intended slits.
- Insert the end of the heating element (1d) into the opening again from inside to outside.

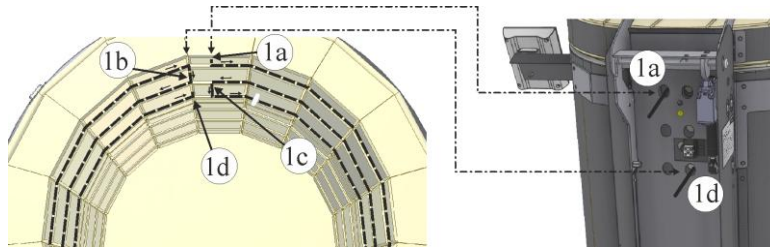

Place the heating wires in the groove(s)

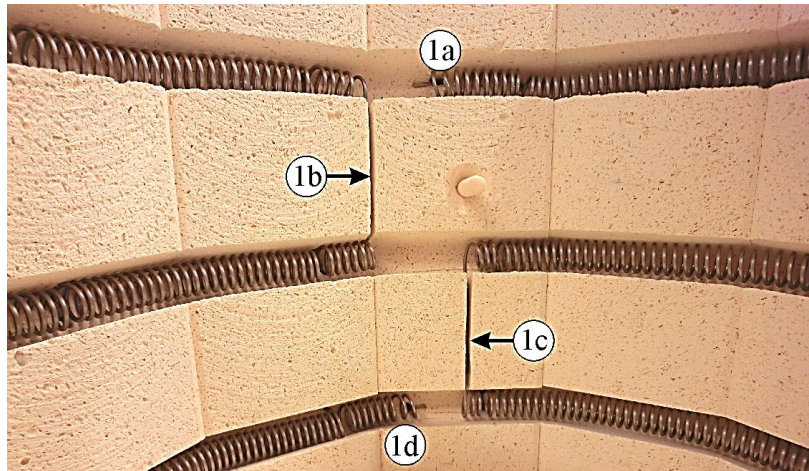

Place the heating wires in the groove(s) (similar to picture)

4. Insert the supplied fasteners into the wall brickwork. They are used to fix the heating elements in the grooves. Do not insert the fasteners into the holes of the previous fasteners. We recommend moving the new fasteners approx. 1 inch (2.5 cm).



	<p>Notice Distance X of the supplied fasteners must not be changed. X ~ 0.55 inches (14 mm)</p>
--	--

5. Expand the heating element a little with a suitable slot screwdriver at the position where a fastener will be inserted (1).

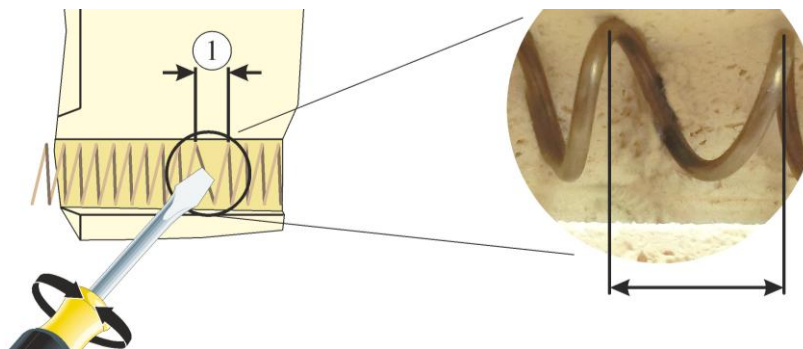

6. Position the fasteners in the straight wall (3) of the groove to ensure that the heating wire sits properly and functions as intended.
7. After installation, check that the heating wire and fasteners are positioned correctly.

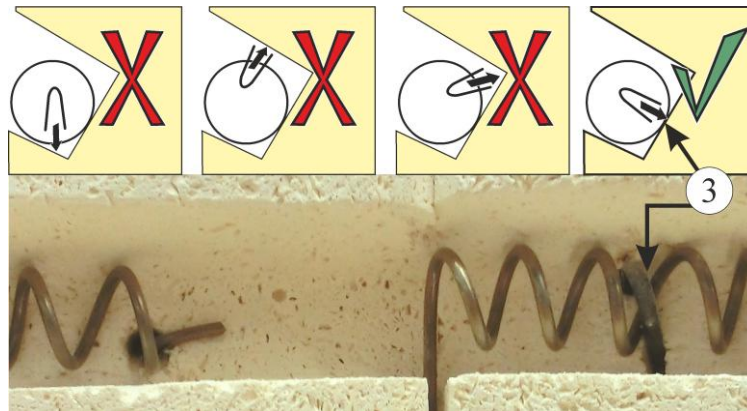

8. As illustrated, use a suitable tool to tap the supplied fasteners carefully into the insulating brick until the heating wire sits completely on the brickwork. Make sure that the insulation brick is not damaged.



9. Seal the gaps in the ceramic feedthrough tubes from outside with a small amount of fiber wadding (included with delivery). To do this, distribute the fiber wadding around the end of the heating element with a small screwdriver (1) and push this from outside to the back of the small feedthrough hole. Do not use too much fiber wadding so that the ceramic feedthrough tubes (2) can still be inserted until they engage.
10. Slide the ceramic feedthrough tube (2) on to the ends of the heating elements until they engage.
11. Slide the connection terminals (3) up to the ceramic feedthrough tube.
12. Use the terminals to create technically correct electrical connections (4).
13. Tighten the screws (5) of the connection terminals (the correct tightening torque can be seen in the table below). So as not to damage the connection terminal or the ceramic feedthrough tube, we recommend the use of a suitable pipe wrench, for example, as a brace when tightening the screws of the connection terminal.
14. Shorten the projecting twisted heating element ends with suitable pincers (6). We recommend that you leave approx. 0.20 inches (0.5 cm) between the edge and the connection terminal.

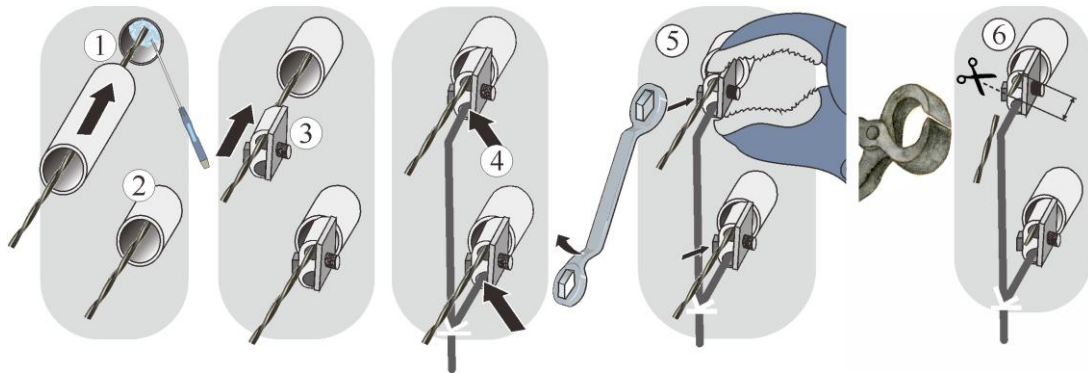

15. Clean the kiln chamber thoroughly with a vacuum cleaner, for example. Pay attention to the heating elements and the thermocouple.

16. The switchgear cover is assembled in the reverse order.

Floor heating elements (model-related)

The floor heating elements are removed and installed in the same way as the wall elements; however, the connections of the heating elements are in these positions.

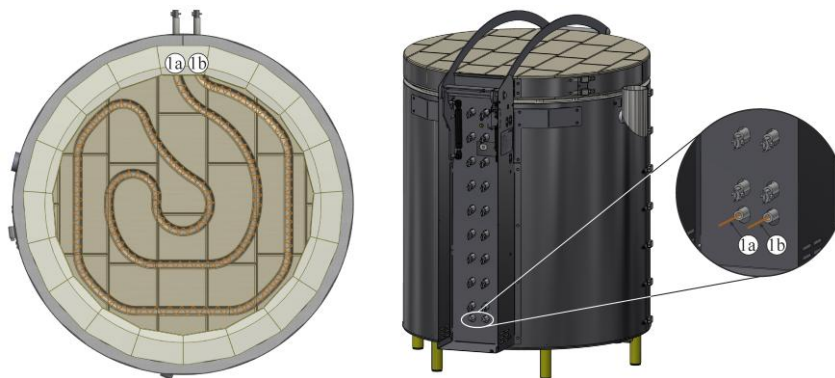

For easier removal and installation, grinding the groove opening with a grinding stone can be helpful:

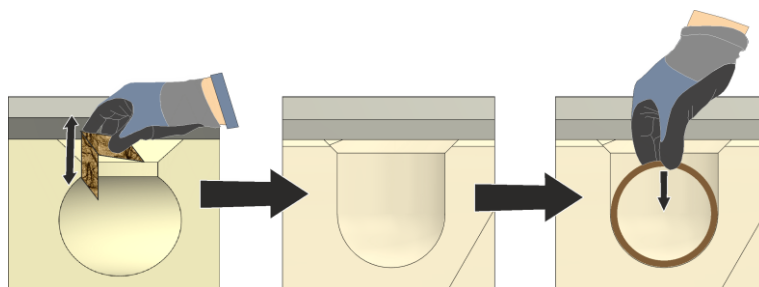

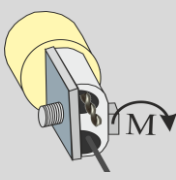

Heating element screw tightening torque

Tighten screw connections on the heating elements with a defined torque. If this advice is not followed, the heating elements may be damaged.

	Thread diameter of metric thread	Torque (M) in Nm
	M5	6 Nm
	M6	8 Nm
	M7	8 Nm
	M8	14 Nm
	M10	20 Nm

7.2 Replacing a Thermocouple

	⚠ DANGER	
	<p>Work on the electrical equipment may be carried out only by a licensed electrician. Danger of electric shock. Pull out the plug or disconnect the kiln from the power supply via the circuit breaker (depends on the model)</p>	

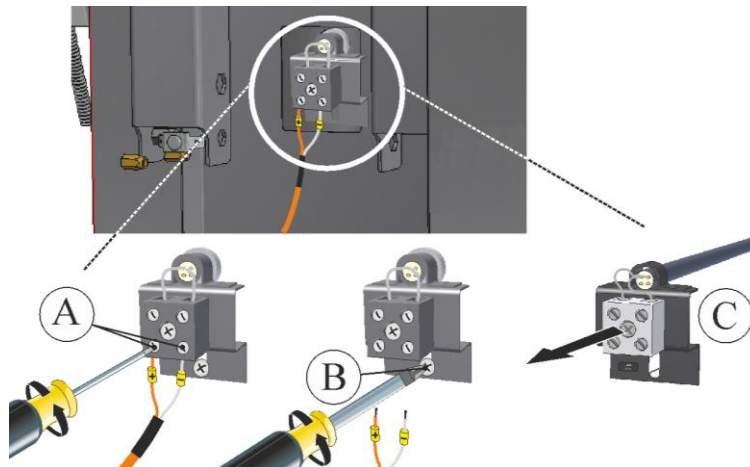

Open the switchgear cover. A description of dismantling and installing the cover(s) and the associated safety instructions can be found in “Replacing the Heating Elements”.



The cable connections from the thermocouple to the controller are marked with \oplus and \ominus . \oplus to \oplus \ominus to \ominus

	<p>Notice</p> <p>The correct assignment of the connections is essential for the kiln to function correctly.</p>
---	--

7.3 Replacing the Gas Strut

	<p style="text-align: center;">⚠ DANGER</p> <p>The kiln must be disconnected from the power supply before starting work. Danger of electric shock. Pull out the plug or disconnect the kiln from the power supply via the circuit breaker (depends on the model)</p>	
SAFETY INFORMATION		
The lid must be completely open and secured to replace the gas strut(s).		

The lid must be completely open to carry out the work safely. Before assembly, make sure that the new gas strut is the same (geometry and force) as the one in the kiln.

Observe the following steps to replace the gas strut(s) safely.

1. First, secure the kiln with the locking brakes on the transport castors to prevent the kiln moving accidentally.

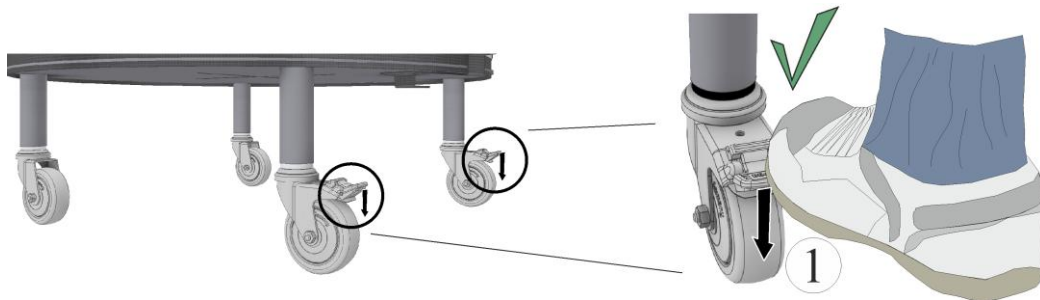

2. Undo the screws (2) of the lid with a suitable screwdriver and keep them in a safe place for future use.
3. Carefully fold down the switchgear cover (3 and 4).

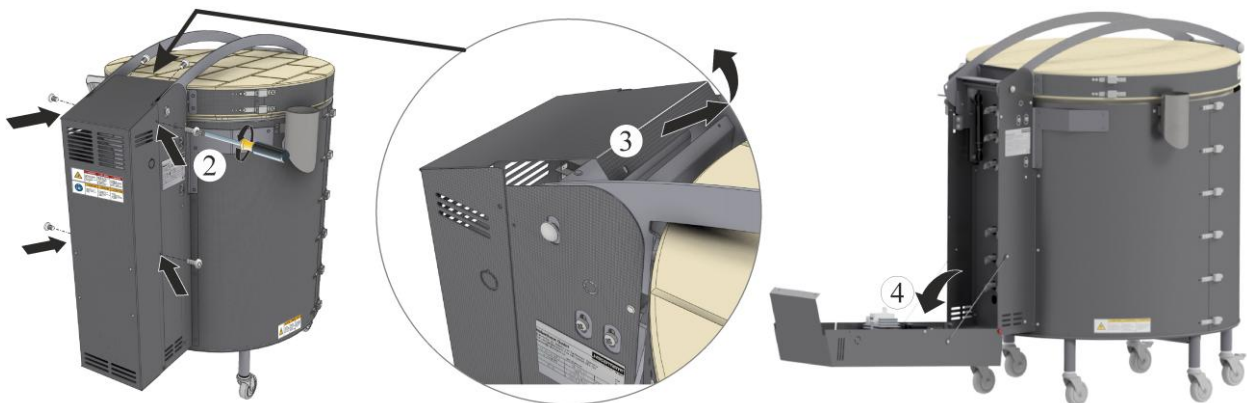

4. Close the lid lock (5) as shown below.
5. Pull the handle (6) to open the lid.

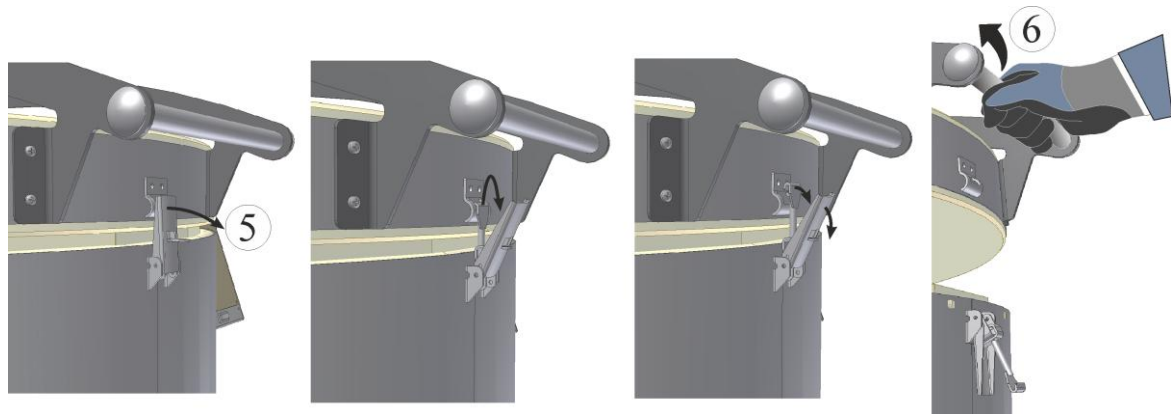

6. The lid must be completely open (7a) The locking mechanism (7b) must audibly secure the lid. To check this, move the lid carefully back and forth (7c). When the lid lock is engaged, you can continue replacing the gas strut.

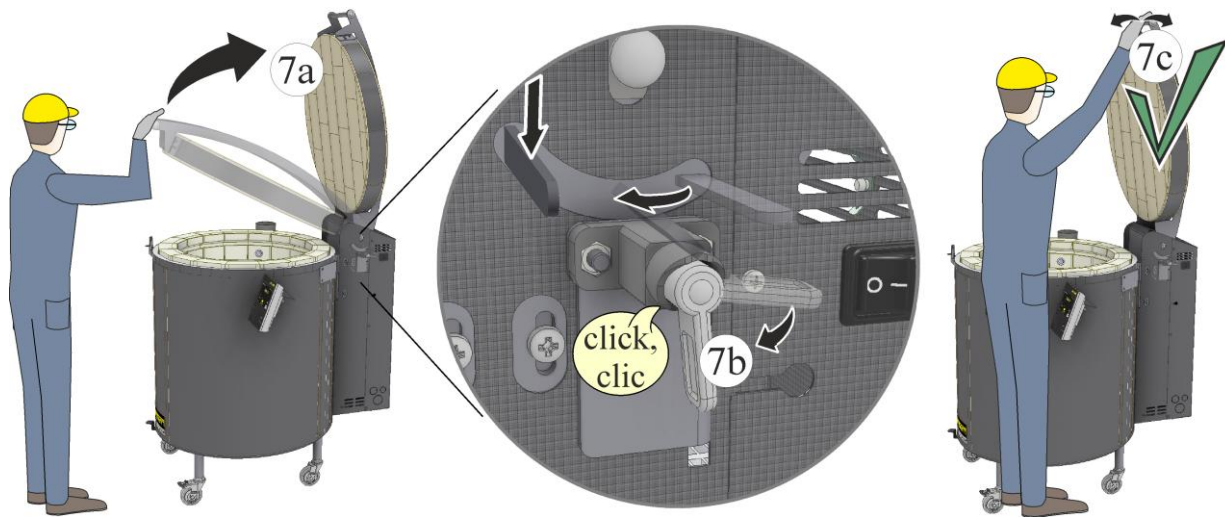

7. Removing the gas strut: Use a small slot screwdriver to lever the retaining clamps (X2) from the gas strut (8). The retaining clamps are located at the ends of the gas strut(s) where it is fixed to the ball heads. Make sure that you do not damage the paint, cables or attached parts.
8. Once you have removed the clamps, you can pull the gas strut away from the ball heads (9).

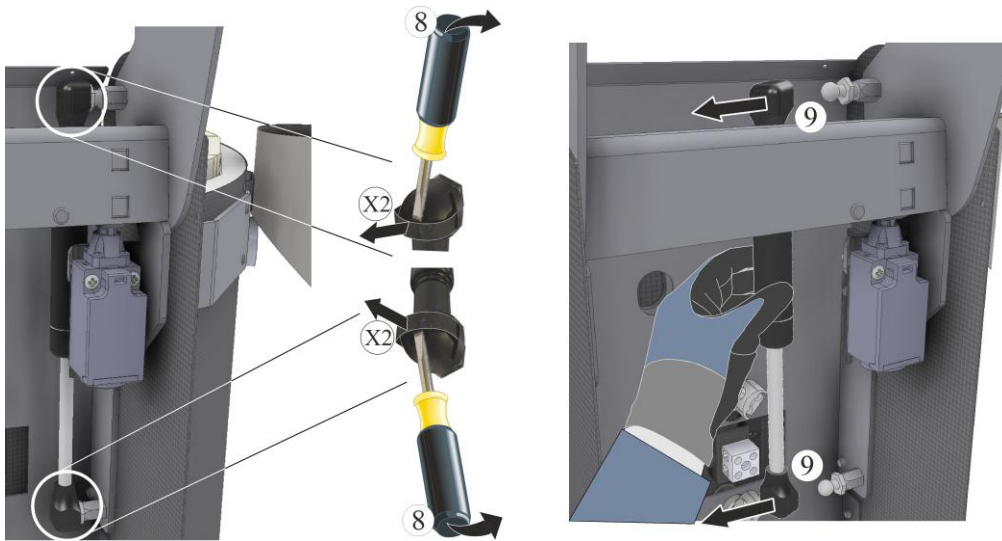

9. Clean the ball heads (10) before attaching the new gas strut(s).

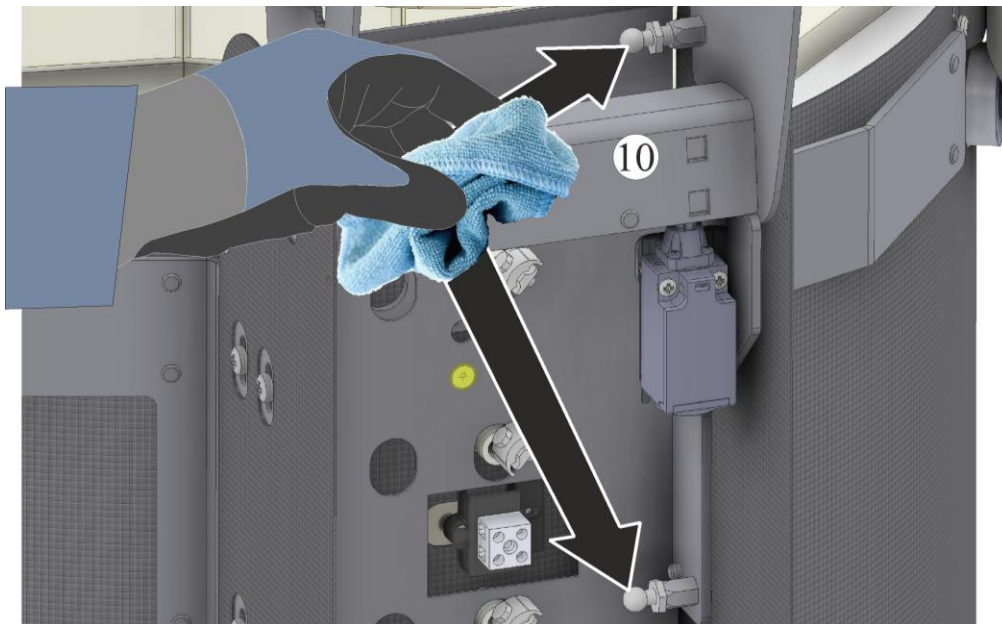

10. Installing the new gas struts: The piston (X2) must face downwards. Place the new gas strut(s) on the ball heads and press them until they engage. Retaining clamps secure the position on the ball head. Make sure that the retaining clamps (12 and 13) sit completely on the housing head of the gas strut(s).

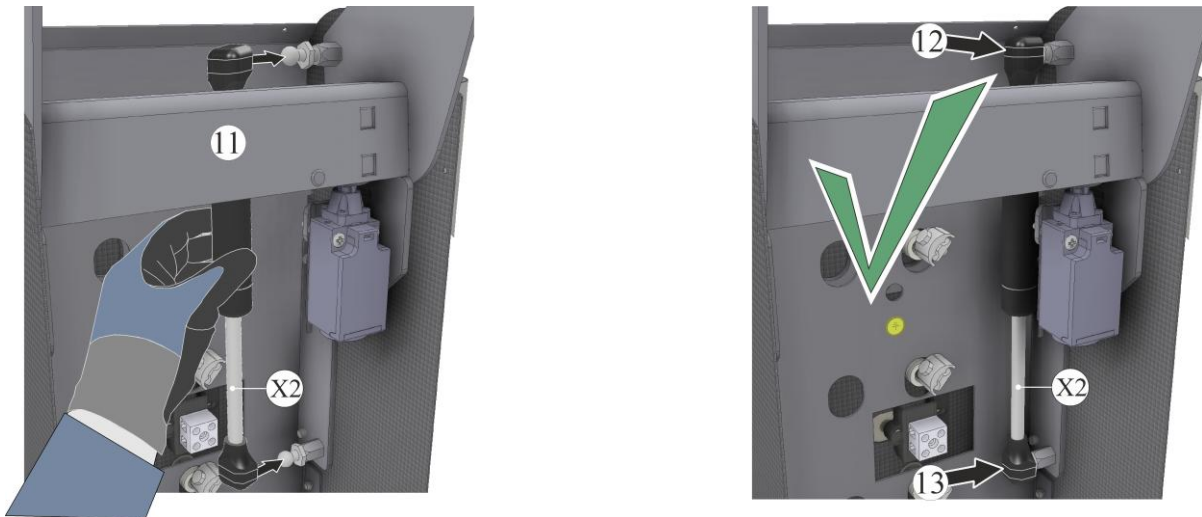

- 11. The lid lock must be unlocked before the function check.
- 12. Check that the lid can be opened and closed with little effort. Due to transportation and storage, the gas strut may initially be stiff.

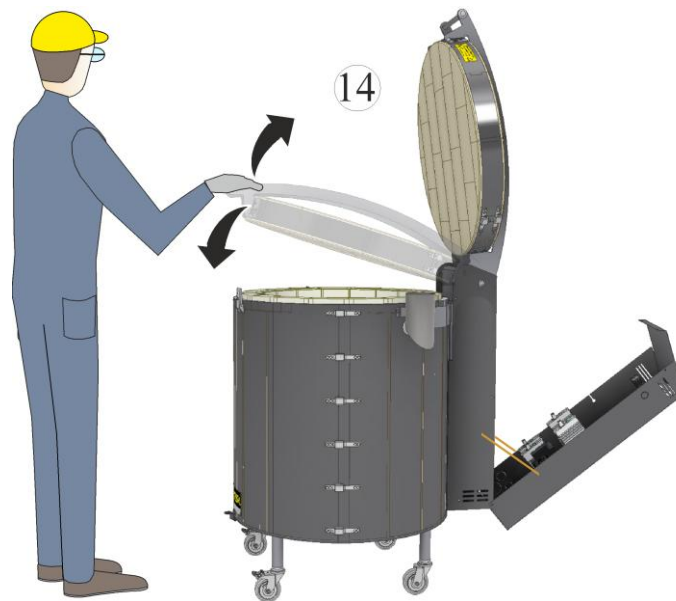





- 13. The switchgear cover is assembled in the reverse order. Make sure that no cables are protruding or trapped. Pay attention to sharp surfaces.

7.4 Replacing Electrical Fuses on the Kiln

	⚠ CAUTION
	Disconnect the power supply before replacing fuses.

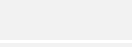
All kilns with power consumption greater than 48 amps are equipped with internal fuses. If the kiln stops heating or is not heating properly, first check the fuses and replace them if necessary.

8 Accessories

	Dimensions in inches	Part number	
Shelf Top 60	Ø13.77x0.39	691 600 397	
Shelf Top 160, Top 190, Top 190/R	Ø20.47x0.59	691 600 834	
Shelf Top 220	21.65x17.32x0.70 (R10.82)	691 601 125	
Prop	Ø1.57x1.96	691 600 185	
Prop	Ø1.57x3.93	691 600 951	
Base Extension Top 60, Top 60/R	Height 5.19	600 0063 632	



9 Nabertherm Service

The Nabertherm Service team is available at all times for kiln maintenance and repair.

If you have any questions, problems, or requirements, contact Nabertherm Inc. by mail, phone or e-mail

USA/Canada	Germany
<p>Mail</p> <p>Nabertherm Inc. 64 Reads Way New Castle, DE 19720 United States</p> <p>Phone</p> <p>Phone +1 302 322 3665</p> <p>Website and e-mail</p> <p>www.nabertherm.com contact@nabertherm.com</p>	<p>Mail</p> <p>Nabertherm GmbH Bahnhofstrasse 20 28865 Lilienthal Germany</p> <p>Phone</p> <p>Phone: +49 (4298) 922-333</p> <p>Website and e-mail</p> <p>www.nabertherm.com contact@nabertherm.de</p>

When contacting us, please have the details on the type plate of the kiln ready.

		
Nabertherm GmbH Bahnhofstr. 20, 28865 Lilienthal/Bremen, Germany Tel +49 (04298) 922-0 contact@nabertherm.com www.nabertherm.com		
①	②	④
③		
		



- ① Kiln model
- ② Serial number
- ③ Article number
- ④ Year or month and year of manufacture

10 Shut-Down, Dismantling, and Storage

Environmental regulations

When it is delivered, the kiln contains no substances that require a hazardous waste classification. However, residues of process materials may accumulate in the kiln insulation during operation. These may be hazardous to health and/or the environment.

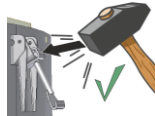
- Dismantle the electronic components and dispose of them as electric scrap.
- Remove the insulation and dispose of it as hazardous waste/hazardous material
- Dispose of the housing as scrap metal.
- Contact the responsible disposal company to dispose of the materials listed above.

SAFETY INFORMATION	
	When the kiln is being disposed of, the lid lock should be destroyed. This stops children being locked in and endangering themselves.
	Separate the power cable and dispose of this together with the plug. This ensures that it cannot be reused and prevents potential hazards.
	Notice The regulations applicable in the country where the equipment is installed must be observed.

11 NABERTHERM LIMITED PRODUCT WARRANTY

All Nabertherm Products (“Products”) sold by Nabertherm, except as provided below, are warranted by Nabertherm for a period of (i) 36 months for Products and (ii) 6 months for Spare Parts, other than Consumables, which period will commence upon date of shipment or invoicing to the reseller whichever occurs first, to be free from any defects in material and workmanship under normal use and service, provided such Products have been properly installed, maintained and operated in accordance with Nabertherm’s specifications for such Product. Any Products repaired or exchanged under Warranty shall be warranted for the longer of the then remaining warranty period or six (6) months. If the Buyer, within such period, notifies Nabertherm in writing of any claimed defect in any Product delivered by Nabertherm and such Product is found by Nabertherm after appropriate test and inspection not to be in conformity with this warranty, Nabertherm will at its option and expense either repair the same or provide a replacement for installation at the Buyer’s expense or refund the purchase price of the Product. Such replacement, repair, or refund shall be the sole and exclusive remedy available to the Buyer. With respect to services performed, if any, Nabertherm’s sole liability for any defect therein shall be to perform again at Nabertherm’s expense, such services, which shall be the sole and exclusive remedy available to the Buyer.

EXCEPT AS AFORESAID, NABERTHERM MAKES NO WARRANTY, EXPRESS OR IMPLIED, INCLUDING WITHOUT LIMITATION ANY IMPLIED WARRANTY AS TO MERCHANTABILITY, FITNESS FOR A PARTICULAR PURPOSE OR ANY OTHER USE OF ANY OF THE PRODUCT REFERRED TO HEREIN OR ANY WARRANTY AS TO THE ABSENCE OF LATENT DEFECTS, OR AS TO THE ABSENCE OF ANY INFRINGEMENT OF ANY PATENT, TRADEMARK, OR COPYRIGHT, AND LIABILITY FOR ANY WARRANTY MADE HEREIN SHALL IN NO EVENT EXCEED THE COST OF CORRECTING DEFECTS IN THE PRODUCT SOLD OR, AT NABERTHERM’S OPTION, OF REPLACING SAME WITH NONDEFECTIVE PRODUCT. NABERTHERM SHALL NOT BE LIABLE FOR ANY CONSEQUENTIAL, CONTINGENT OR INCIDENTAL DAMAGES WHATSOEVER INCLUDING, WITHOUT LIMITATION, BACK CHARGES.

WITHOUT LIMITING THE GENERALITY OF THE FOREGOING, THE FOREGOING WARRANTY DOES NOT COVER, AND NO WARRANTY IS MADE WITH RESPECT TO:

- A. Failure or defect not reported within the warranty period above specified.
- B. Failures or damage due to negligence (other than that of Nabertherm), accident, abuse, improper installation (other than installation made by Nabertherm), improper operation or abnormal conditions of temperature, moisture, dirt or corrosion.
- C. Products, which have been tampered with, repaired or altered by anyone other than an authorized representative of Nabertherm.
- D. Product damaged in shipment or otherwise without the fault of Nabertherm.
- E. Expense incurred by the Buyer in an attempt to correct or repair any alleged defect, unless approved by Nabertherm in writing.
- F. Components and other materials purchased by Nabertherm from other manufactures and resold to Buyer either in the form acquired by Nabertherm or in assembly with other components and materials. As an accommodation to the Buyer, Nabertherm will, upon request of the Buyer, assign to the Buyer any rights it may have arising out of warranties given by any manufacturer of such components, materials or standard equipment purchased by Nabertherm and so resold to the Buyer.
- G. Any Product manufactured by Nabertherm in response to the Buyer specifications therefore which go beyond the existing state of the art. Nabertherm assumes no liability for any failure of such Product so to meet such specifications.
- H. Failure or defects attributable to design or specifications requested by the Buyer.
- I. Specifications and dimensions shown in this quotation, proposal or order confirmation which are approximate and are subject to minor devaluations or tolerance in accordance with industry standard.
- J. Such components, which by their nature in normal usage of the Product in accordance with Nabertherm's specifications therefore, have a life expectancy shorter than the warranty period, and are referred to as "Consumables" which include thermocouples, heating elements, gloves, seals, o-rings, sight glasses, and pump fluids.
- K. Nabertherm's scope of supply includes only the Products sold by Nabertherm and describes specifically herein. Any additional safety procedures and/or equipment that may be required or recommended by federal, state, or local codes, your insurance policies or for your intended use is not included within this warranty. You are responsible for providing any and all such additional procedures and equipment as necessary.

If you need warranty service please contact and initiate your claim with the dealer that installed and sold the Products. All warranty claims must be initiated prior to the lapse of the warranty period. Nabertherm does not assume any responsibility for claims initiated after the lapse of the warranty period. This warranty is conditioned upon your reasonably cooperating with Nabertherm (and any dealer or other party Nabertherm designates) in the evaluation of your warranty claim and the implementation of any remedy. Reasonable cooperation includes, without limitation, your providing pictures of the claimed defect upon request. This warranty is further conditioned upon Nabertherm and its designee having the opportunity to evaluate the Products at the location of its installation. Nabertherm also reserves the right to decline a claim if you are unable or unwilling to provide proof of purchase, the date of purchase and installation, the name of the builder, contractor or dealer that installed and sold the Products, and a written confirmation that you are the original end-user purchaser of the Products.

Some States do not allow limitations on how long an implied warranty lasts, so the above limitation may not apply to you. This warranty gives you specific legal rights, and you may also have other rights that vary from State to State.

12 For Your Notes

